

UK

# HE-VA

Operating Instructions  
Spare Parts List  
Declaration of Conformity

it looks

As good as it looks

As good as it looks

As good as it looks

As good as it looks

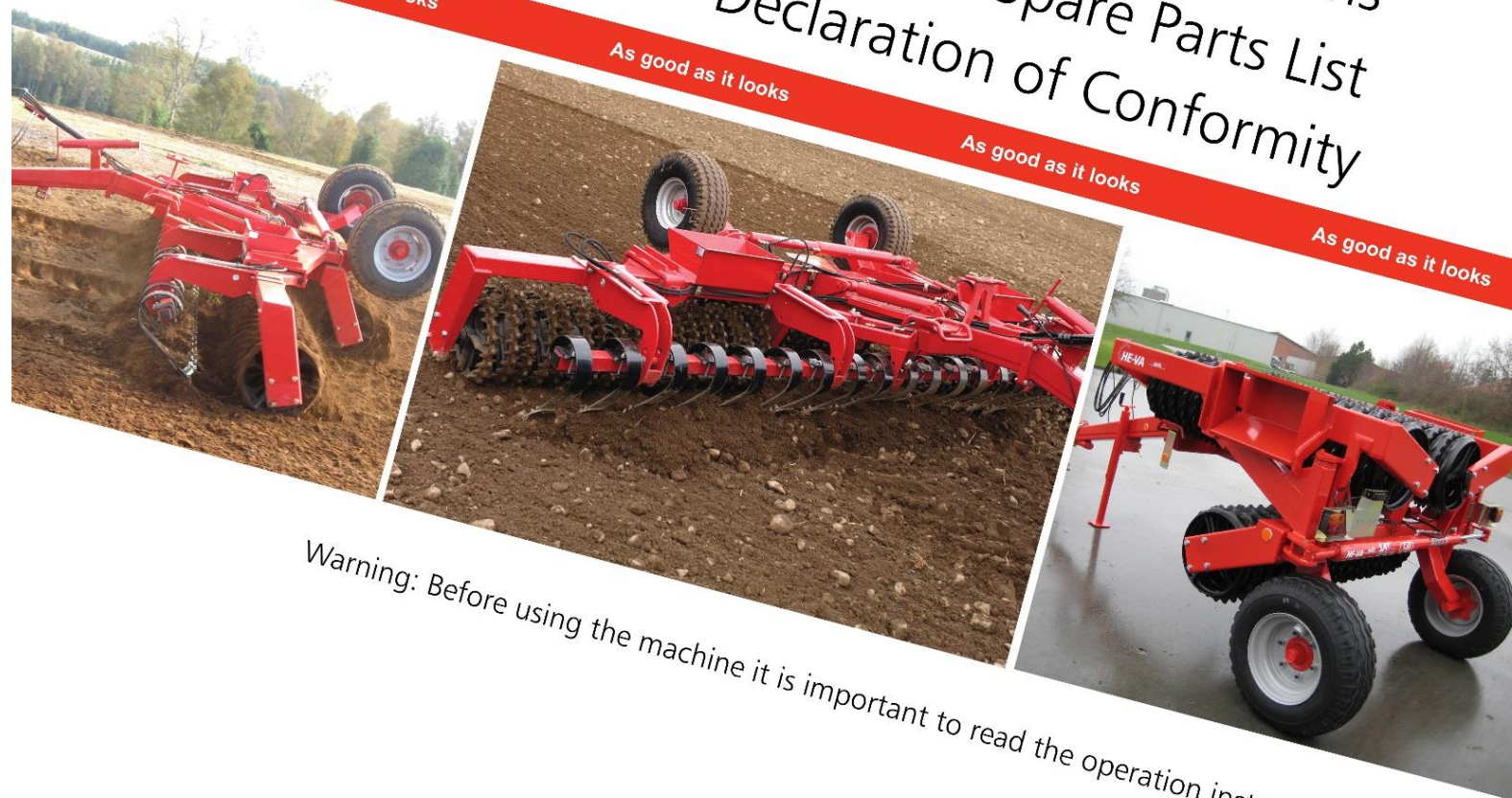

Warning: Before using the machine it is important to read the operation instructions.

Manual no. 8000341-04 071024

## Tip-Roller

4.5 m - 5.4 m - 6.3 m

(excl. 6.3 m w/560 & 620 mm Cambridge rings,  
550/600 mm Star rings, 550/600 mm Crosskill rings  
& 550 & 600 mm 2D-Corrugated rings)



N. A. Christensensvej 34  
DK-7900 Nykøbing Mors  
Tel: 97724288  
Fax: 97722112  
[www.he-va.com](http://www.he-va.com)



## Table of Contents

EC DECLARATION OF CONFORMITY .....	4
Description of the machine .....	5
Delivery Check .....	5
Instructions for unloading and final assembly .....	5
Transport Brackets .....	5
Specifications.....	6
Technical specifications .....	6
Operating Instructions .....	6
Attachment .....	6
Transport .....	7
When rolling.....	8
Maintenance.....	8
Lubrication chart.....	9
Safety for Tip-Roller.....	10
Safety Instructions, regarding Hydraulic System .....	11
Disposal .....	11
Markings on the machine.....	12
Notes .....	13
Spare Part List, Roller.....	14
Drawbar before May 2010 .....	14
Drawbar after May 2010 .....	16
Center Section .....	18
Wing Side Section.....	19
Center section for Ø620 rings after machine number: 342089 .....	20
Wing and Side Section Ø620 rings after machin number: 342089 .....	21
Roller Block .....	22
Hydraulic Roller .....	24
Spring-Board.....	26
Installation of Cylinder on the Spring-Board .....	26
Spring-Board, Center Section.....	27
Spring-Board – Left Side Section .....	30
Lights .....	33
LED Light kit .....	33
Light kit: Electrical diagramme.....	34
Easy Change System.....	35



## **EC DECLARATION OF CONFORMITY**

in accordance with the EU Machinery Directive 2006/42/EC  
applicable as from December 29<sup>th</sup> 2009:

HE-VA ApS  
N. A. Christensensvej 34  
DK-7900 Nykøbing Mors

hereby confirms that the following machine has been manufactured in accordance with the Council  
Directive 2006/42/EC.

The declaration comprises the following machine:

Tip – Roller 4,5m – 5,4m – 6,3m

Nykøbing the 29th December 2009

A handwritten signature in black ink, appearing to read 'Villy Christiansen', is written over a horizontal line. The signature is fluid and cursive.

Villy Christiansen

The undersigned is furthermore authorised to compile technical documentation for the above machine.

## **Description of the machine**

The Tip-Roller is a 3-sectioned hydraulic, wheel mounted roller. Tip-Roller is to be used for packing the top soil, to maintain the content of moisture in it, and to eliminate not solid stones from the surface of the cultivated area.

The roller sections has an independent suspension. Side sections are center-mounted in an intermediate joint, connecting the side sections to the wheel frame, which gives the sections a perfect adaption to the ground in uneven areas. The changing between transport- and work position is by hydraulic force. The roller has a low and compact transport position with a width of 2,2 or 2,42 meters.

**Read the manual before operating the roller and strictly follow the safety instructions.**

## **Delivery Check**

Check the roller for any damages. Check the hydraulic hoses for cuts and squeezing damages. Check also the other hydraulic components, are not damaged during transport. Check that the frame construction has not been damaged. You should also check that the roller blocks have not been exposed to impacts, which may have damaged the cast roller rings or the double-sealed ball bearings.

*Finally check that the transport wheels are tightened and OK.*

*Check the air pressure in the tyres according to Technical Specifications chart next page*

## **Instructions for unloading and final assembly**

In order to minimize the roller's space during transport, the roller is supplied partially separated from the factory. If the machine is delivered unassembled, it must therefore be completely installed first.

### **Transport Brackets**

At delivery the machine is mounted with brackets for hoisting gear, which is not painted.

These brackets is for attachment of chains or straps, when loading or unloading the machine from the transport vehicle, and they must be dismantled before use.



## Specifications

3-section hydraulic wheel-mounted field roller with free movement in all sections. The roller is delivered with a working width of 4,5 - 5,4 - 6,3 meters, respectively, with 6 different ring types: cambridge- camstar- 2D wave- cross-kill ring and rigid roller.

### Technical specifications

Work width m.	4,5	5,4	6,3
Width in workposition m.	4,75	5,64	6,55
Length m.	4,0	4,0	4,95
Transport width m.	2,2	2,2	2,42
Transport hight m. w / without add.equipment	1,62/2,44	1,62/2,44	1,72 / 2,54
Weight kg basic machine depending on ring type	1.510 - 2.810	1.880 - 3.240	2.110 - 4.190
Wheel size	10.0/75x15,3 - 10 PLY	11.5/80x15.3 – 14 PLY	400/60x15,5 - 16 PLY
Max tyre pressure bar/psi	3,9/57	4,7/68	4,3/62
Oil pressure	min. 150 bar		
Hydraulic outlets	2 pc double function		
Quick couplings, standard	Sterling type E 402		
Hydraulic oil	Hydro Texaco HD32, Specification DIN 51524-3 / ISO 11158 L-HV		

## Operating Instructions

### Attachment

On delivery the roller is in transport position. When the roller is attached, check that the towing hook height is 500-600 mm. Reverse the tractor, put in and **secure** the draw bolt.

Attention: Check that the towing eye fits the height of the tractors drawbar

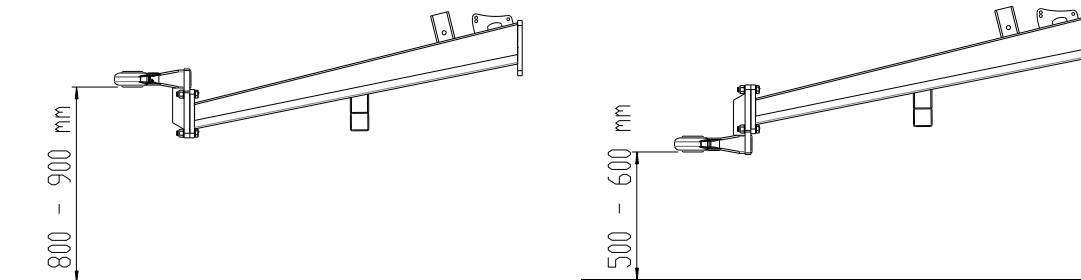

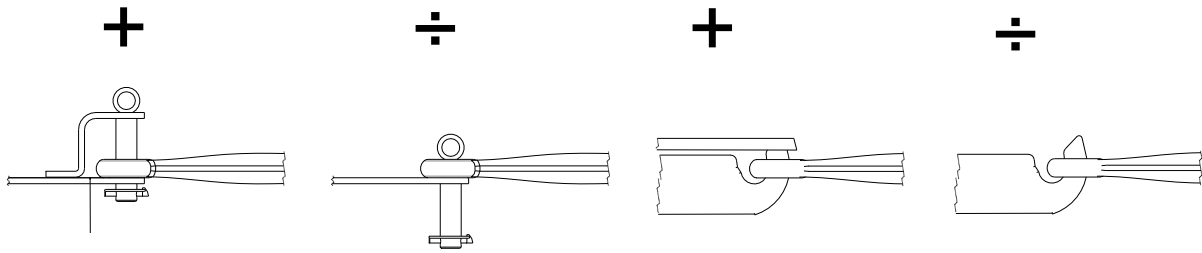

Raise the support leg and place it in the transport fittings on top of the drawbar. Now fit the four hydraulic hoses.

The hoses for the tip cylinder are provided with **red** tie strap.

The hoses for the wing cylinder are provided with **blue** tie strap.

**Important:**

Check that the male end mounted by the factory fits the female end of the quick couplings of the tractor.  
 Now pressurise the tip cylinder (red) so that the side sections are tipped free of the transport fittings.  
 Then the wing cylinder (blue) is pressured so that the wings are turned as much back as possible.  
 Now relieve the pressure on the tip cylinder, and the roller will tip forward down to working position. When the bottom has been reached, let go of the hydraulic handle and the roller is ready for use.

**Transport**

At change-over for transport, the roller is tipped totally backward by pressurising the tip cylinder. Now pressurise the wing cylinder so that the side sections turn forward, towards the stop on the transport fittings of the drawbar.  
 When both sides lie in parallel with the drawbar, they are lowered down into the transport fittings by unpressurising the tip cylinder. Then relieve the pressure on all hydraulic hoses, and the roller is ready for transport.

**INSTRUCTIONS FOR TRANSPORT AT PUBLIC ROADS:**

Before transport at public roads, make sure that the attachment of the implement to the tractor, is in accordance with the local rules and regulations in force (permitted total weight, permitted axel load, transport width, lights and warning signs).

**FRONT AXEL LOAD:**

When the implement is attached and at maximum load, the tractors driving properties must be ensured. Check that the front axel is sufficiently loaded. The front axel load must be at least 20% of the tractors weight. Permitted axel load and total weight for the tractor must be respected.

**NB! The driving, controlling and braking properties are affected by the attached implement**



### When rolling

Speed: max. 10 km/h.

When turning, drive in wide curves as far as possible. The turning should be performed no sharper, than all roller rings are still rotating forward.

Only lower the wheels when making ready for transport position.

Do not drive over any large stones, which are not moveable.

## Maintenance

- A. After approx. 10 hours of operation, retighten the wheels, ball bearings and stop rings. Check hoses, fittings and cylinders for any leaks and retighten.

Maximum torque according to ISO 898-1 in Nm. <b>With lubricated thread</b>			
Metric thread	Quality 8.8	Quality 10.9	Quality 12.9
M10x1,5	38	54	63
M12x1,75	66	95	110
M14x2,0	105	150	176
M16x2,0	164	235	274
M18x2,5	233	323	377
M20x2,5	331	458	535
M22x2,5	450	622	727
M24x3,0	572	791	925
Wheel nut M18x1,5 fine thread		360 Nm	
Wheel nut M22x1,5 fine thread		550 Nm	

### **Control tightening:**

- flange for towing eye, 6 bolts M16 in quality 10.9
- flanges between drawbar and the rear drawbar 6 or 12 bolts M16 in quality 10.9

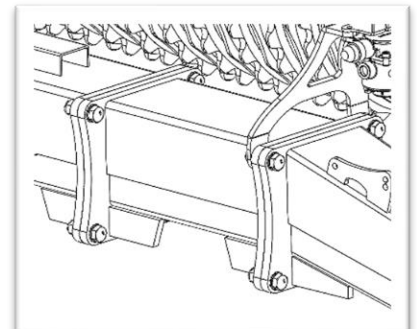
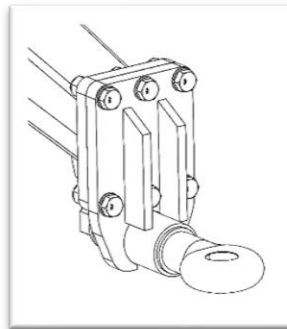

- B. After every approx. 10 hours of operation, lubricate all movable parts in the side sections as well as the three lubrication points of the wing cylinder. After every 30 hours of operation, lubricate the tip cylinder pin and the three pins in the drawbar.
- C. After the season, lubricate the roller with grease and oil. Lubricate the piston rods with grease or conservation oil.

**Lubrication chart**

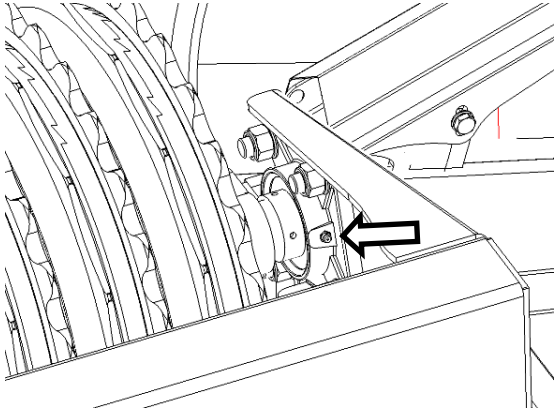
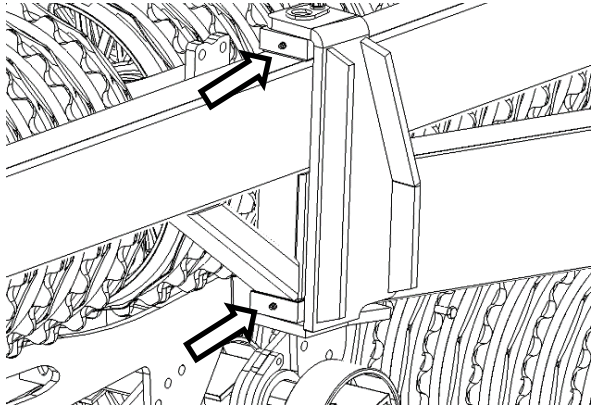
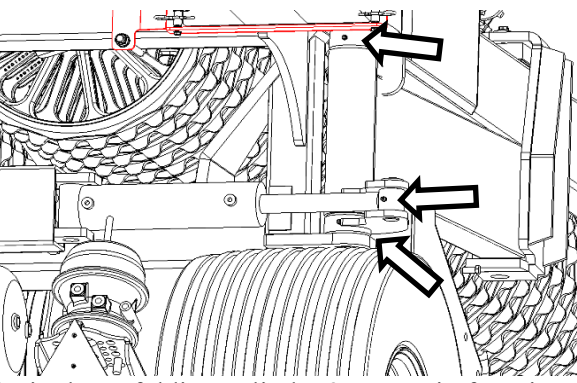
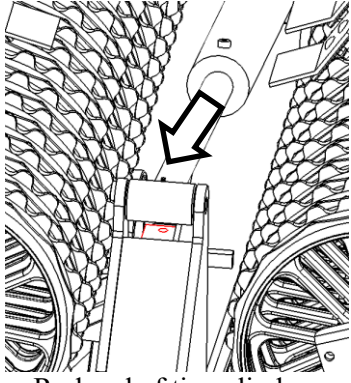
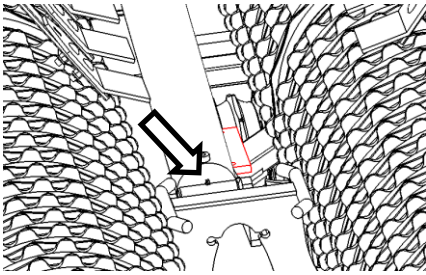
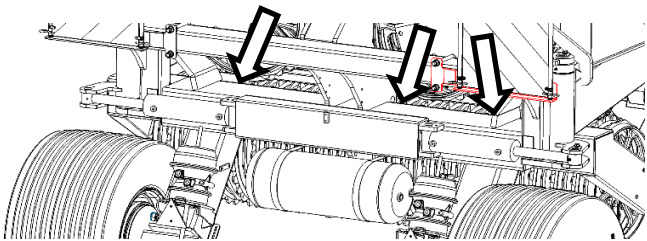
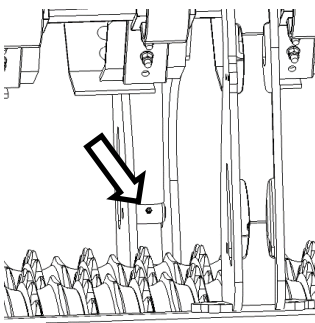
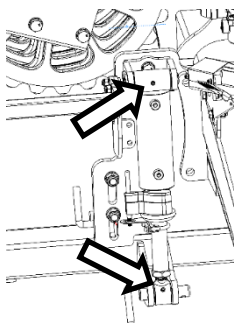
 <p>All ends on roller blocks, twice each season and after wash</p>	 <p>2 nipples on wings pivot joints 10 hours</p>
 <p>1 nipple on folding cylinder 2 pc on pin for wings 10 hours</p>	 <p>Rod end of tip cylinder 30 hours</p>
 <p>Cylinder end of tip cylinder 30 hours</p>	 <p>3 nipples on pivot joint between rear drawbar and wheel frame 30 hours</p>
 <p>1 nipple on each Spring-Board cylinder 10 hours</p>	 <p>2 nipples at track eradicator cylinder 10 hours</p>

## Safety for Tip-Roller

Do not operate the machine, **if any people<sup>1</sup>** are at risk in **the dangerous area.<sup>2</sup>**

When persons are at risk in the dangerous area (e.g., when doing adjustments, maintenance or connect or disconnecting), the following points must be met:

- Lower the machine on solid ground.
- Hydraulic must be relieved.
- Tractor must be turned off, and the key removed.
- Driver must be aware of, when operating that there are no persons at risk in the dangerous area.
- He-Va cannot be held responsible for any falling accidents due to washing lubrication and other maintenance tasks
- By the time tires will become tender and explosion danger can occur, when transporting or when controlling tire pressure
- Drive carefully when going from road to paddock and opposite. Be aware of ditches along the road and holes in dirt roads because gravity point is reasonable high in transport position. Especially when additional equipment is mounted
- The machine must not be operated by persons who have not been properly instructed or trained

Most accidents when operating the machine, transporting, and doing maintenance occurs, when avoiding the simplest safety regulations.

For this reason, it is of highest importance, that any person who is operating the machine, strictly follows the safety regulations and other instructions, which belongs the machine.

The machine must only be operated, maintained, and fixed by persons, who is confidential with and skilled for this work and is aware of moments of danger, which can occur.

**ATTENTION!!** Rotating parts and loose in a loose condition, is a dangerous combination.

**IMPORTANT!!** It is strictly prohibited for any person to take place on the frame of the machine, when it is either operating or the tractor is idling.

---

<sup>1</sup> People at risk: Any person, who is completely or partially in the dangerous area.

<sup>2</sup> Dangerous area: At the machine and underneath it, and in distance of 4 m from it.



## **Safety Instructions, regarding Hydraulic System**

1. The highest allowable pressure is 225 bar.
2. It is recommended to mark the hydraulic connections between the implement and tractor, to avoid incorrect operation!
3. When checking for hydraulic leaks, suitable safety gear must be used due to danger. (Safety goggles , gloves, etc.)  
At high pressure, Hydraulic oil can penetrate the skin and cause serious injuries.  
At injuries, consult a doctor immediately. **RISK OF INFECTION!**
4. Before any work at the hydraulic system, the implement must be lowered to solid ground.  
Pressure must be relieved, engine stopped, and ignition key removed.
5. Check the hydraulic hoses on a regular basis, however, every six months as a minimum due to any cracks, wear and tear, etc. Replace any defective hoses immediately.
6. Hydraulic hoses last for no more than 5 years.  
New hydraulic hoses must be identical to the manufacturer's specifications.

## **Disposal**

When, after many years of use, the machine is to be regarded as end-of-life, it must be disposed of to a registered and approved product dealer. This will carry out the statutory discharge and disposal of hydraulic oil, as well as sorting materials for further processing for recycling.



## Markings on the machine

Several markings are located at your machine, which contains **safety regulations** and other instructions to inform about correct operating.

Please read these instructions carefully and make the driver aware about the markings and **safety regulations** in this Operating Instructions. Keep the markings clean and readable. If they are not, they must be replaced.

### Safety – and other markings on the machine

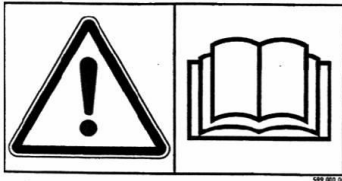

Study the Operating Instructions thoroughly before any operation of the machine and observe all safety instructions.

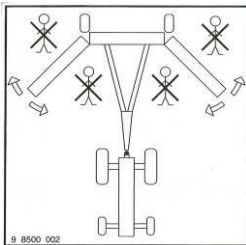

Take care that no persons are within the machine's hazardous area during the unfolding and folding procedure.



Plate with number and year of manufacture.

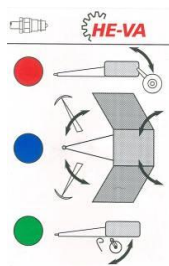

Identification marks for the hydraulic system:

- Red:** Tip cylinder
- Blue:** Folding cylinder
- Green:** Additional equipment



Tighten up the bolts regularly. If this is not performed, our warranty obligations will no longer apply.

Notes

--	--

## Spare Part List, Roller

Drawbar before May 2010

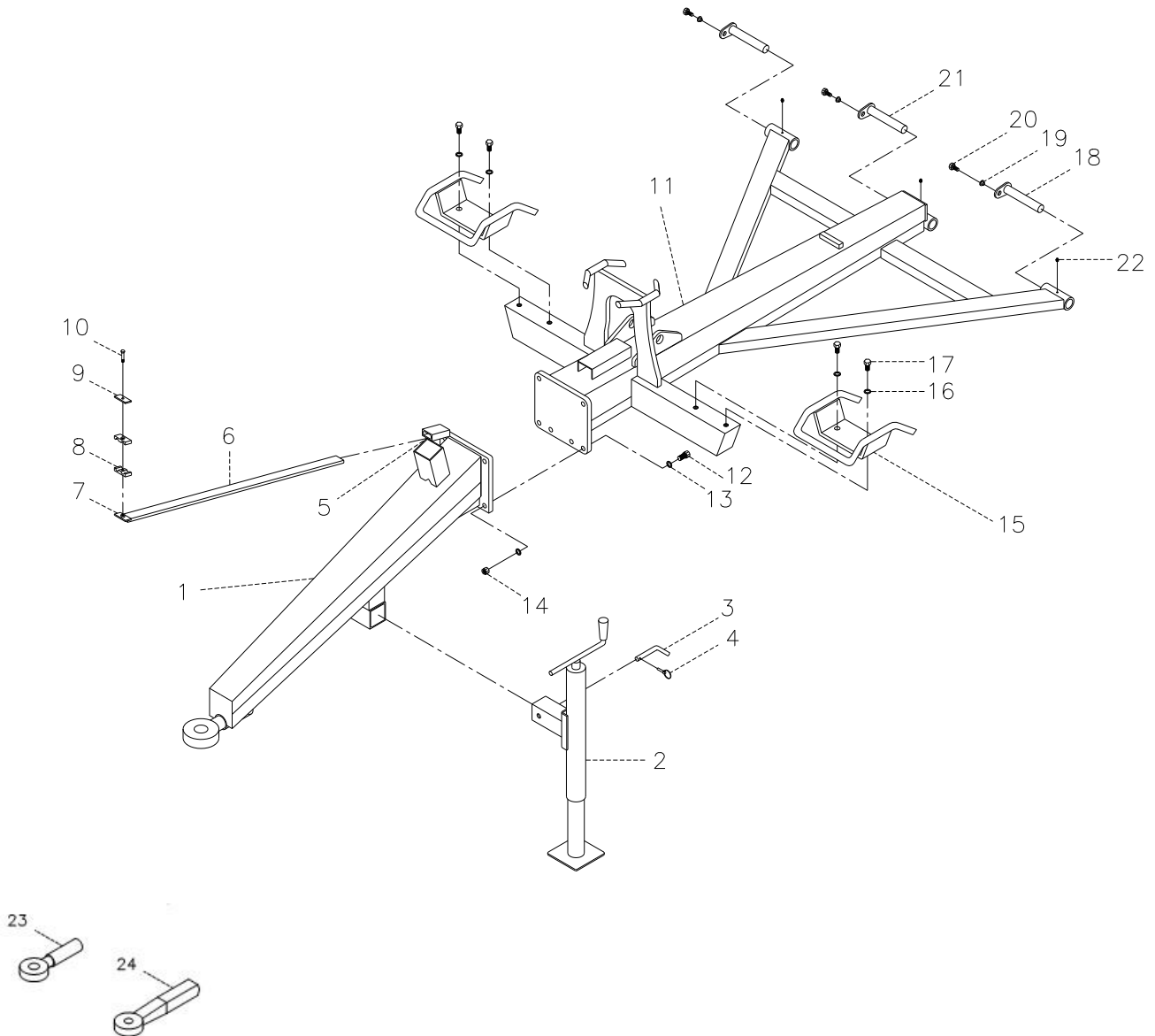

Pos.	Art. no.	Designation	4,5m	5,4m	6,3m
1	630751000	Front drawbar (Danish)	1	1	1
1	630876000	Front drawbar (German)	1	1	1
2	690141100	Support leg 3500 kg (Danish)	1	1	1
2	690141101	Support leg 3500 kg (German)	1	1	1
3	69516094A	Pin ø16	1	1	1
4	0377400	Hairpin ø4 mm	1	1	1
5	0235040	M10x25 bolt	2	2	2
6	630771200	Parking device for hose	1	1	1
7	690210212	Weld. pl. f/double tube support (ø14, ø15, ø16, ø18)	1	1	1
8	690210210	Tube support, double ø14/ø14	2	2	2
9	690210211	Top pl. f/double tube support (ø14, ø15, ø16, ø18)	1	1	1
10	690210213	Screw for double tube support (ø14, ø15, ø16, ø18)	1	1	1
11	630715000	Back drawbar	1		
11	630725000	Back drawbar		1	
11	630755000	Back drawbar			1
12	690103128	Bolt M16x65 10.9	6	6	6
13	0272900	Facetted disc Ø16	12	12	12
14	0264090	Self-locking nut M16	6	6	6
15	630530300	Transport fittings Ø450 mm	2	2	2
15	630530400	Transport fittings Ø510 mm	2	2	2
16	0272900	Facetted disc Ø16	4	4	4
17	690103124	Bolt M16x35 mm	4	4	4
18	69530145G	Pin ø30 L=145	2	2	2
19	630532600	Locking bush for pin head	3	3	3
20	690101101	Bolt M12x25	3	3	3
21	69530175G	Pin ø30 L=175	1	1	1
22	0432510	Lub. nipple M8	3	3	3
23	690141211	Drawbar (Danish)	1	1	1
24	690105003	Drawbar (German)	1	1	1



**Drawbar after May 2010**

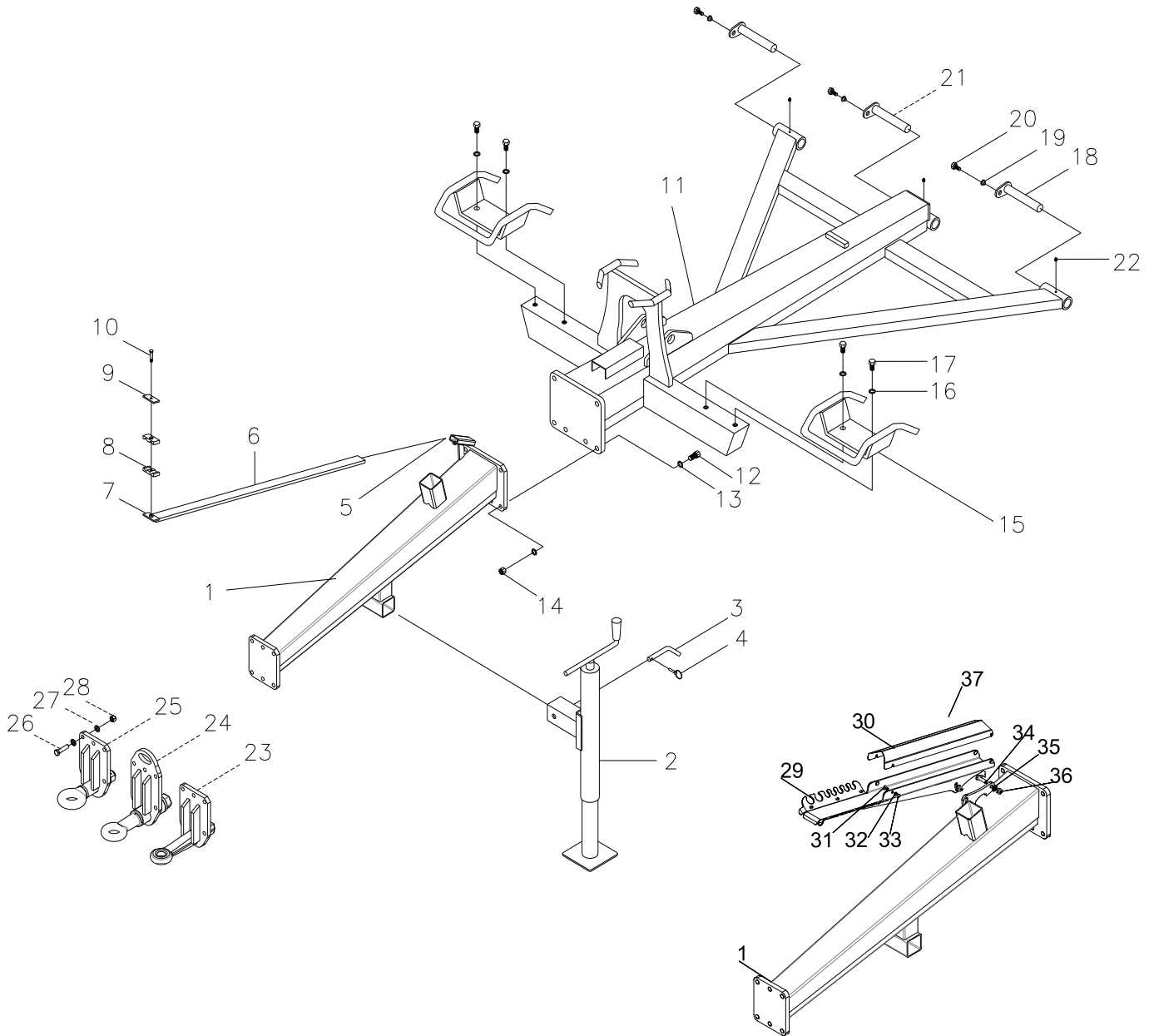

Pos.	Art. no.	Designation	4,5m	5,4m	6,3m
1	630757032	Front drawbar	1	1	1
1	630757097	Front drawbar for new parking device	1	1	1
2	690141100	Support leg 3500 kg	1	1	1
3	69516094A	Pin ø16	1	1	1
4	690133005	Hairpin ø4 mm	1	1	1
5	690103075	M10x25 bolt	2	2	2
6	630771200	Parking devise for hose	1	1	1
7	690210212	Weld.pl. f/double tube support (ø14, ø15, ø16, ø18)	1	1	1
8	690210210	Tube support, double ø14/ø14	2	2	2
9	690210211	Top pl. f/double tube support (ø14, ø15, ø16, ø18)	1	1	1
10	690210213	Screw f/double tube support (ø14, ø15, ø16, ø18)	1	1	1
11	630715000	Back drawbar	1		
11	630725000	Back drawbar		1	
11	630755000	Back drawbar			1
11	630536200	Back drawbar for Ø620 ringe <b>after machin no. 342089</b>	1		
11	630546200	Back drawbar for Ø620 ringe <b>after machin no. 342089</b>		1	
12	690103275	Bolt M16x65 10.9	6	6	6
13	0272290	Facetted disc Ø16	12	12	12
14	0264090	Self-locking nut M16	6	6	6
15	630530300	Transport fitting Ø450 mm	2	2	2
15	630530400	Transport fitting Ø510 mm	2	2	2
16	0272900	Facetted disc Ø16	4	4	4
17	690103124	Bolt M16x35 mm	4	4	4
18	69530145G	Pin Ø30 L=145	2	2	2
19	630532600	Locking bush for pin head	3	3	3
20	690101101	Bolt M12x25	3	3	3
21	69530175G	Pin Ø30 L=175	1	1	1
22	0432510	Lub. nipple M8	3	3	3
23	630757013	Drawbar Ø40 solid M16 bolts	1	1	1
23a	690105003	Loose towing eye, Ø40			
24	630757025	Drawbar Ø50, pivoted, homologeret M16 bolts	1	1	1
24a	690105004	Loose towing eye, Ø50, pivoted, homologeret			
25	630757028	Drawbar, Ø50, pivoted M16 bolts	1	1	1
25a	690141211	Loose towing eye, Ø50, pivoted			
26	690103275	Bolt M16x65 10.9	6	6	6
27	0272290	Facetted disc Ø16	12	12	12
28	0264090	Self-locking nut M16	6	6	6
29	7345001	Parking devise for hose 8 places	1	1	1
29	7345002	Parking devise for hose 14 places	1	1	1
30	7345003	Cover for parking devise	1	1	1
31	0246060	Bolt	4	4	4
32	0272240	Facetted disc 6mm	4	4	4
33	0264040	Self-locking nut M6, DIN985	4	4	4



Pos.	Art. no.	Designation	4,5m	5,4m	6,3m
34	0235360	Bolt M12x40mm,8.8 fzg	2	2	2
35	0272270	Facetted disc Ø12	4	4	4
36	0264070	Self-locking nut M12 DIN985	2	2	2
37	7345010	Complete parking device for hoses 8 places (pos 33-40)			
37	7345019	Complete parking device for hoses 14 places (pos 33-40)			

### Center Section

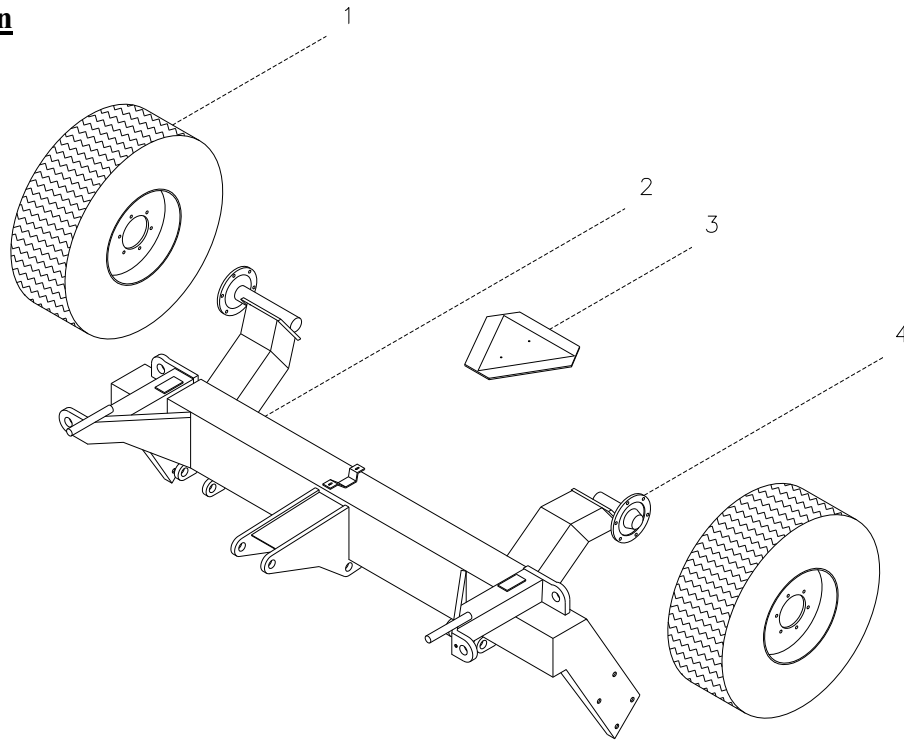

Pos.	Art. no.	Designation	4,5m	5,4m	6,3m
1	690141310	Wheel 10.0/75 x 15.3 10 layers	2	2	2
1	690141215	Hjul 11.5/80x15.3 - 14pr from machin no. <b>349836</b>			2
2	630712000	Center frame	1		
2	630722000	Center frame		1	
2	630752000	Center frame			1
3	690142001	Warning triangle	1	1	1
3a	0233860	Bolt M5x20	2	2	2
3b	0264030	Nut M5	2	2	2
3c	0272230	Facetted disc Ø5	2	2	2
4	690141025	Hub 7050.6-M18/161-205 1700 kg	2	2	2
4a	690141039	Hub bolt M18x1,5x49	12	12	12
4b	0396470	Hub nut M18	12	12	12
4f	0395260	Hub cap Ø62	2	2	2

**Wing Side Section**

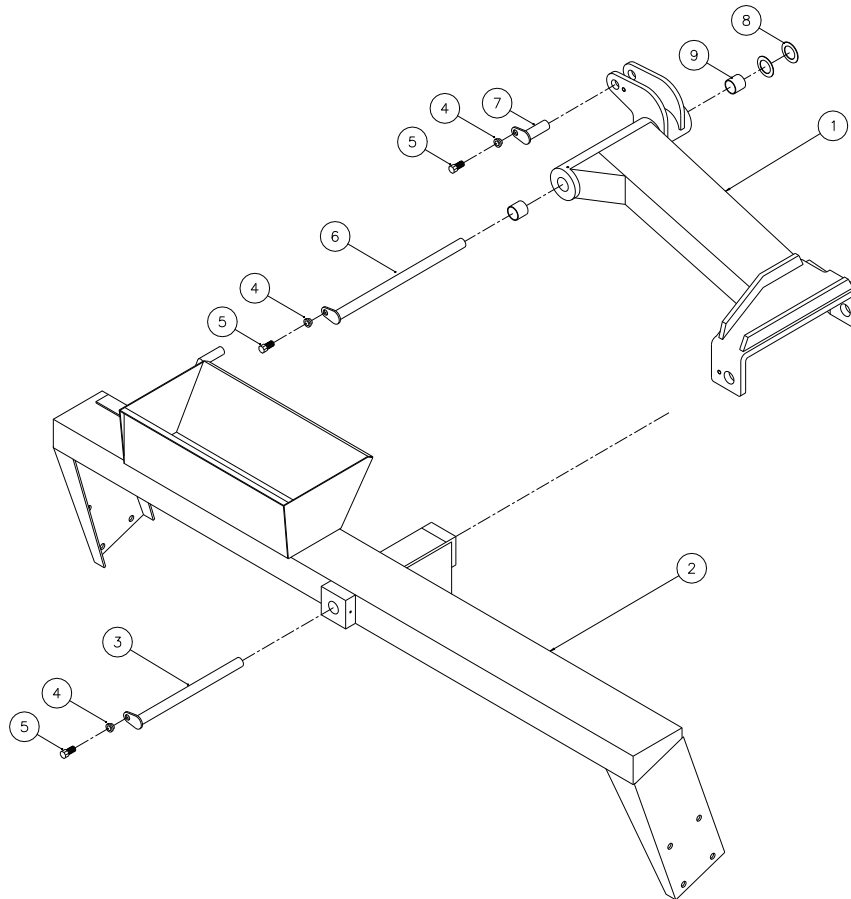

Pos.	Art. no.	Designation	4,5m	5,4m	6,3m
1	630713011	Wing right	1		
1	630723011	Wing right		1	
1	630753007	Wing right			1
1	630713010	Wing left	1		
1	630723010	Wing left		1	
1	630753003	Wing left			1
2	630714000	Side section left	1		
2	630724000	Side section left		1	
2	630754000	Side section left			1
2	630714100	Side section right	1		
2	630724100	Side section right		1	
2	630754100	Side section right			1
3	69440425G	Pin ø40 L = 425	2	2	2
4	630532600	Bush for pin head	6	6	6
5	690101101	Bolt M12x25	6	6	6
6	69440525G	Pin ø40 L = 525	2	2	2
7	69430090G	Pin ø30 L = 90	2	2	2
8	690140714	Sliding disc Ø42/Ø66x1,5	4	4	4
9	0475100	Sliding bush Ø40/Ø44 L=40	4	4	4

**Center section for Ø620 rings after machine number: 342089**

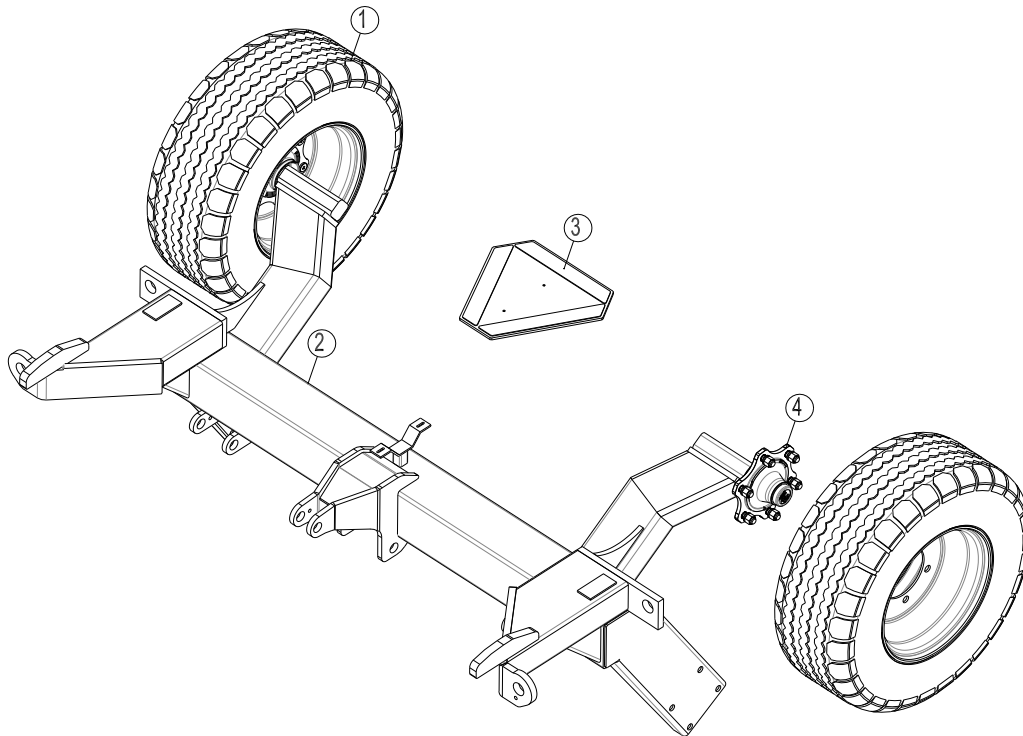

Pos.	Art. no.	Designation	4,5m	5,4m
1	690141310	Wheel10.0/75 x 15.3 10 layers	2	2
2	630536300	Centerframe	1	
	630546300	Centerframe		1
2	630536325	Centerframe w/side section lock	1	
	630546325	Centerframe w/side section lock		1
2a	630536521	Locking pin for side section lock Ø35 L=340	2	2
2b	690134010	Split for locking pin	2	2
3	0521010	Warning triangle	1	1
3a	0233860	Bolt M5x20	2	2
3b	0264030	Nut M5	2	2
3c	0272230	Facetted disc Ø5	2	2
4	0395440	Hub M18/160-205 1700 kg	2	2
4a	690141039	Hub bolt M18x1.5x49	12	12
4b	0396470	Hub nut M18	12	12
4f	0395436	Hub cap ø62	2	2

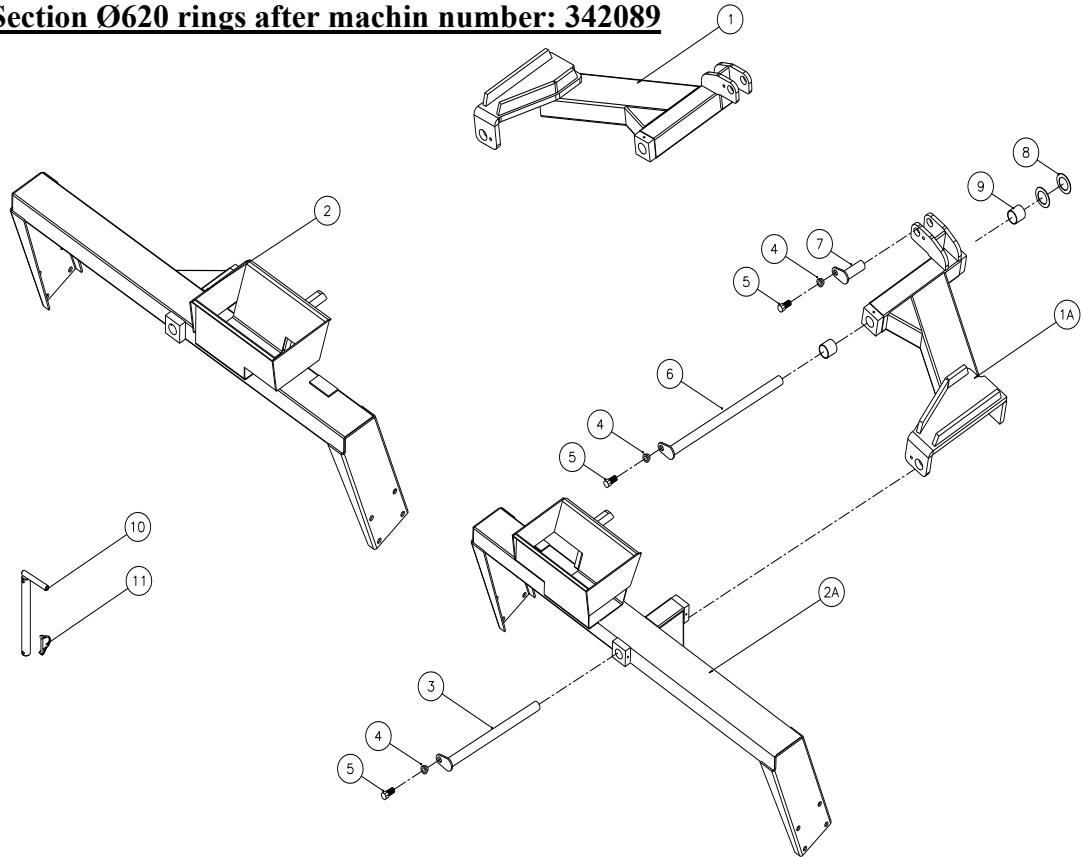
**Wing and Side Section Ø620 rings after machin number: 342089**

Pos.	Art. no.	Designation	4,5m	5,4m
1	630536410	Wing right	1	
1	630536425	Wing right w/side section lock	1	
1	630546410	Wing right		1
1	630546425	Wing right w/side section lock		1
1A	630536400	Wing left	1	
1A	630536420	Wing left w/side section lock		
1A	630546400	Wing left		1
1A	630546420	Wing left w/side section lock		
2	630536510	Side section right	1	
2	630546510	Side section right		1
2	630536525	Side section right w/side section lock	1	
2	630546525	Side section right w/side section lock		1
2A	630536500	Side section left	1	
2A	630546500	Side section left		1
2A	630536515	Side section left w/side section lock	1	
2A	630546515	Side section left w/side section lock		1
3	69440425G	Pin ø40 L = 425	2	2
4	630532600	Bush for pinhead	6	6
5	690101101	Bolt M12x25	6	6
6	69440525G	Pin ø40 L = 525	2	2
7	69430090G	Pin ø30 L = 90	2	2
8	690140714	Sliding disc Ø42/Ø66x1,5	4	4
9	0475100	Sliding bush Ø40/Ø44 L=40	4	4
10	630536521	Pin for side section lock Ø35 L=340	2	2
11	690134010	Split 8mm	2	2



**Roller Block**

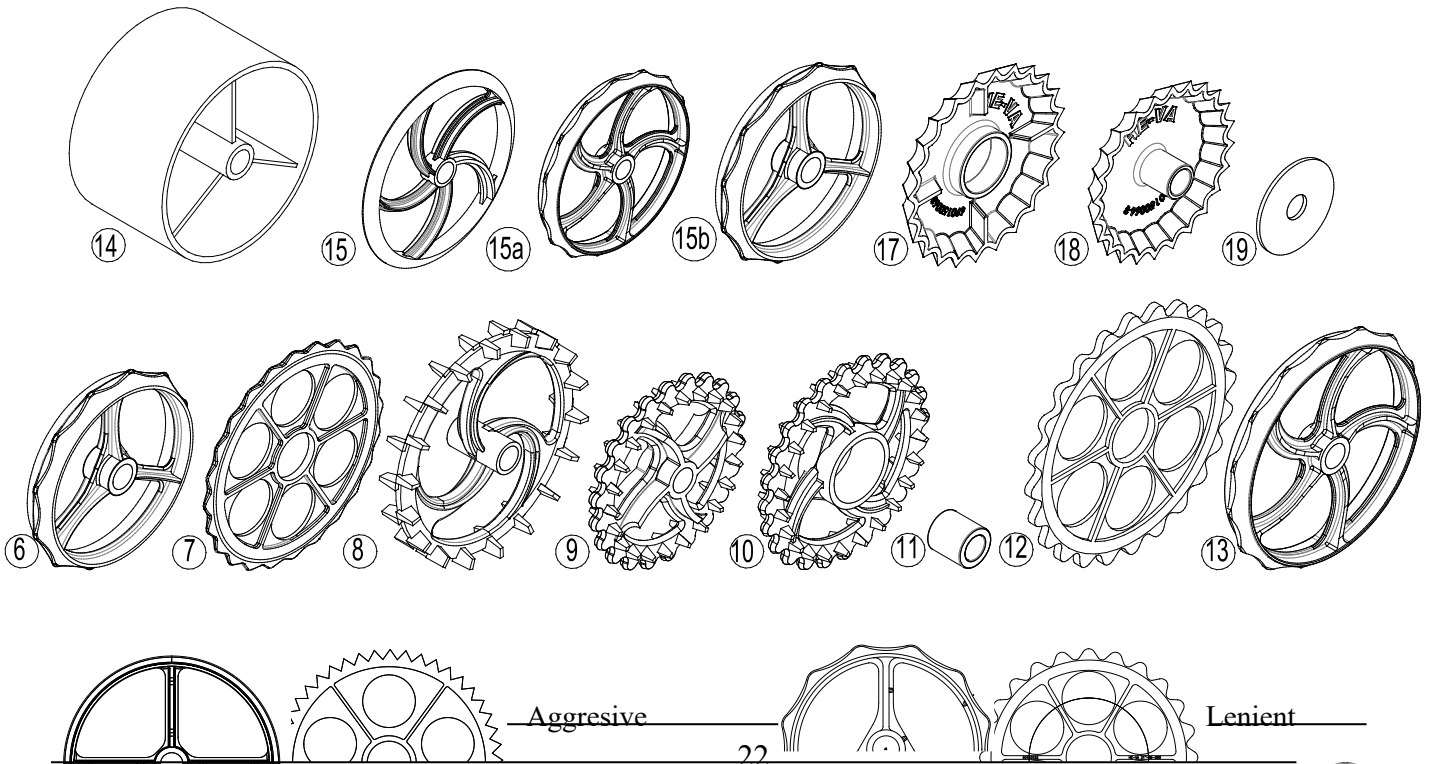
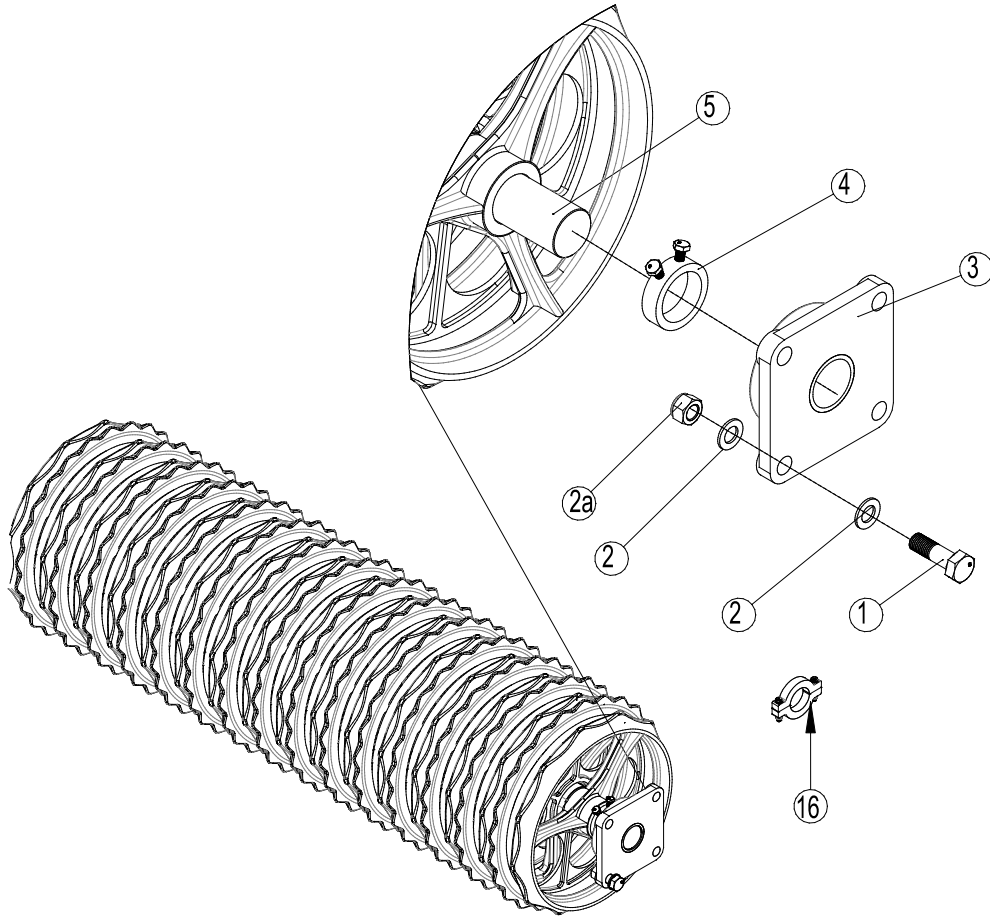

Pos.	Art. No.	Designation	4,5 m	5,4 m	6,3 m
1	0235830	Bolt M16x55	24	24	24
2	0272290	Facetted disc ø16	48	48	48
2a	0264090	Self-locking nut M16	24	24	24
3	690140812	Bearing UCF 309, ø45, 4-hole, ø50 axle	6	6	6
3	690140813	Bearing UCF 211, ø55, 4-hole, ø60 axle	6	6	6
4	630552300	Stop ring with bolt, ø50 axle	3	3	3
4	671040400	Stop ring with bolt, ø60 axle	3	3	3
4a	691040045	Set screw for bearing UCF 309, M10x1.25 L=12	6	6	6
4a	691040046	Set screw for bearing UCF 211, M10x1.0 L=10	6	6	6
5	678541736	Axle for centre + side sections Ø50 ST70 L=1736	3	0	0
5	678542066	Axle for centre + side sections Ø50 ST70 L=2066	0	3	0
5	678542370	Axle for centre + side sections Ø50 CrNi L=2370	0	0	3
5	678661736	Axle for centre + side sections Ø60 ST70 L=1736	3	0	0
5	678662063	Axle for centre + side sections Ø60 ST70 L=2063	0	3	0
5	678662370	Axle for centre + side sections Ø60 ST70 L=2370	0	0	2
5	678692370	Axle for centre Ø60 CrNiMo6 L=2370	0	0	1
6	690150039	Cambridge plain ring Ø450 (Ø60) Lenient	45	54	63
7	690150040	Cambridge breaker ring Ø450 (Ø60) Lenient	42	51	60
6	690150024	Cambridge plain ring Ø510 (Ø60) Aggressive	45	54	63
6	690150030	Cambridge plain ring Ø510 (Ø60) Lenient	45	54	63
7	690150025	Cambridge breaker ring Ø510 (Ø60) Aggressive	42	51	60
7	690150032	Cambridge breaker ring Ø510 (Ø60) Lenient	42	51	60
8	690150007	Cam ring 22" (Ø50)	30	36	42
9	690150034	Crosskill ring ø485 mm (Ø60)	24	27	33
9	690150074	Cross-killring Ø550 mm (Ø60)	24	27	
10	690150011	Loose Crosskill ring ø530 mm	21	27	30
10	690150075	Løs cross-killring Ø600 mm	21	27	
11	690150076	Hub for loose Crosskill ring Ø60	21	27	30
12	690150059	Breaker ring 24" Ø620 <b>after machin no. 342089</b>	42	51	0
13	690150049	Plain ring 24" Ø620 <b>after machin no. 342089</b>	45	54	0
12	690150102	Breaker ring Ø560	42	51	
13	690150101	Plain ring Ø560	45	54	
14	690150028	Plainring Ø505 (ø60)	15	18	21
15	690150013	Corrugated ring Ø500 (ø60) <b>END 1. april 2011</b>	90	108	126
15a	690150050	2D Corrugated ring 600 mm 5 spokes <b>New from 1. april 2011</b>	57	69	
15a	690150109	2D Corrugated ring 550mm 5 spokes	57	69	
15b	690150087	2D Corrugated ring 500 mm 3 spokes <b>New from 1. april 2011</b>	57	69	78
16	690150091	Adjustment shim 25mm, complete set with bolts			
16	690150090	Adjustment shim 15mm, complete set with bolts			

16	690150099	Adjustment shim 20mm, complete set with bolts			
17	690150063	Star ring Ø500, Center Ø135	45	54	63
18	690150064	Star ring Ø450 w/neck Ø60	45	54	63
17	690150065	Star ring Ø600, Center Ø135	45	54	
18	690150066	Star ring Ø550 w/neck Ø60	45	54	
19	690150112	Round plate Ø235 for mounting star rings	3	3	3

### Hydraulic Roller

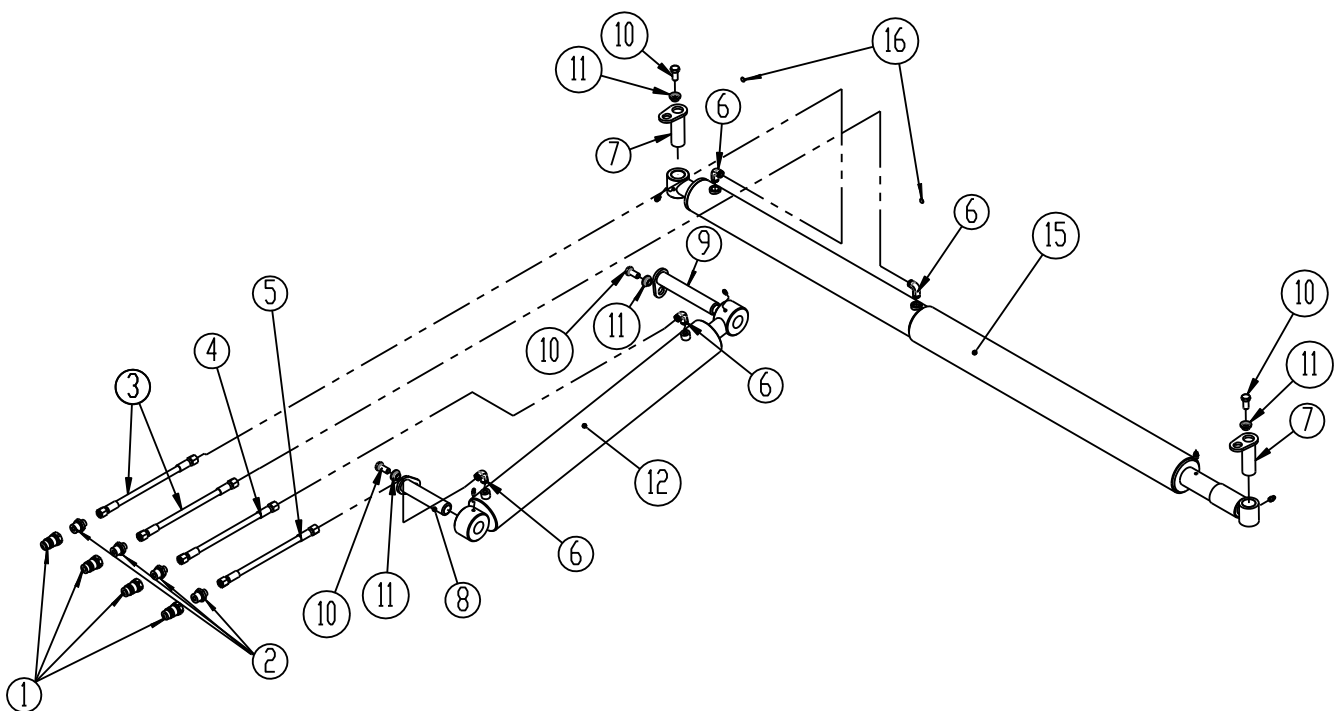

Pos.	Art. No.	Designation	4.5 m	5.4 m	6.3 m
1	690203001	Quick-coupling ½" male	4	4	4
1a	690119202	Tie strap blue	2	2	2
1b	690119203	Tie strap red	2	2	2
2	690203003	Screw-in straight GA10LK ½"	4	4	4
3	690201004	Hydraulic hose 1/4" L=4950 mm	2	2	0
3	690201034	Hydraulic hose 1/4" L=5500 mm	0	0	2
4	690201006	Hydraulic hose 1/4" L=3800 mm	1	1	0
4	690201029	Hydraulic hose 1/4" L=4300 mm	0	0	1
5	690201005	Hydraulic hose 1/4" L=3300 mm	1	1	0
5	690201007	Hydraulic hose 1/4" L=3700 mm	0	0	1
6	690203006	Screw-in angle VA10LK 3/8"	4	4	4
7	69430090G	Pin ø30 L=90	2	2	2
8	69530135G	Pin ø30 L=135	1	1	1
9	69430175G	Pin ø30 L=175	1	1	1
10	690101101	Bolt M12x25	4	4	4
11	630532600	Locking bush for pin head	4	4	4
12	690200050	Tip cylinder 80/40x500 mm	1	1	0
12	690200350	Tip cylinder 90/40x500mm v/Ø620mm Cambridgeringe <b>after machin no. 342089</b>		1	
12	690200120	Tip cylinder 80/40x600 mm	0	0	1
12e	690200143	Packing set 80/40	-	-	-
13	690200010	Wing cylinder for weight balancing cylinder 60/30x500	1	1	0
13e	690200076	Packing set 60/30	-	-	-
13	690200030	Wing cylinder for weight balancing cylinder 70/40x600	0	0	1
13e	690200068	Packing set 70/40	-	-	-
15	630727010	Weight balancing cylinder	1	1	0
15	630757010	Weight balancing cylinder	0	0	1
16	690207901	Restrictor 1 mm	2	2	2



## Spring-Board

The Spring-Board requires a double-acting oil outlet on the tractor. The tine angle is hydraulically controlled from the driver's cap, with manual depth control. The tines work independently of each other, but can be coupled together by means of a transverse locking fittings (accessories), if a greater levelling output is required. The replacement is done easily and without use of any tools.

### Installation of Cylinder on the Spring-Board

The hydraulic cylinders are installed as shown below. It is important that they are installed correctly in order to achieve the proper force of the cylinders.

The ring type determines whether the cylinders must be installed in hole 1 or hole 2. If the machine is with 450 or 550 mm rings, the cylinders must be installed in hole 1 and hole 1a or 1b. If the machine is with 620 mm rings, the cylinders must be installed in hole 2 and hole 2a or 2b.

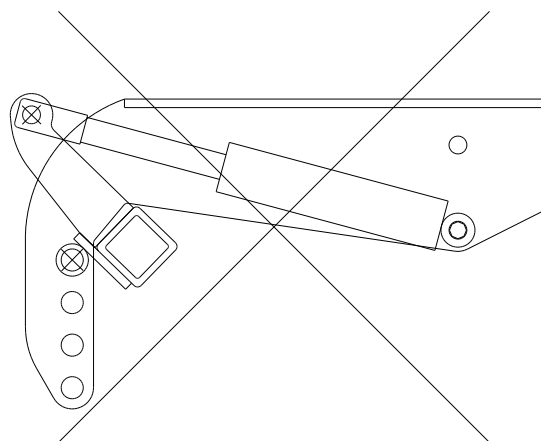
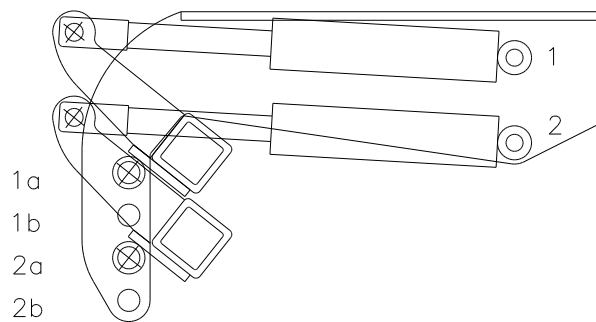

**Spring-Board, Center Section**

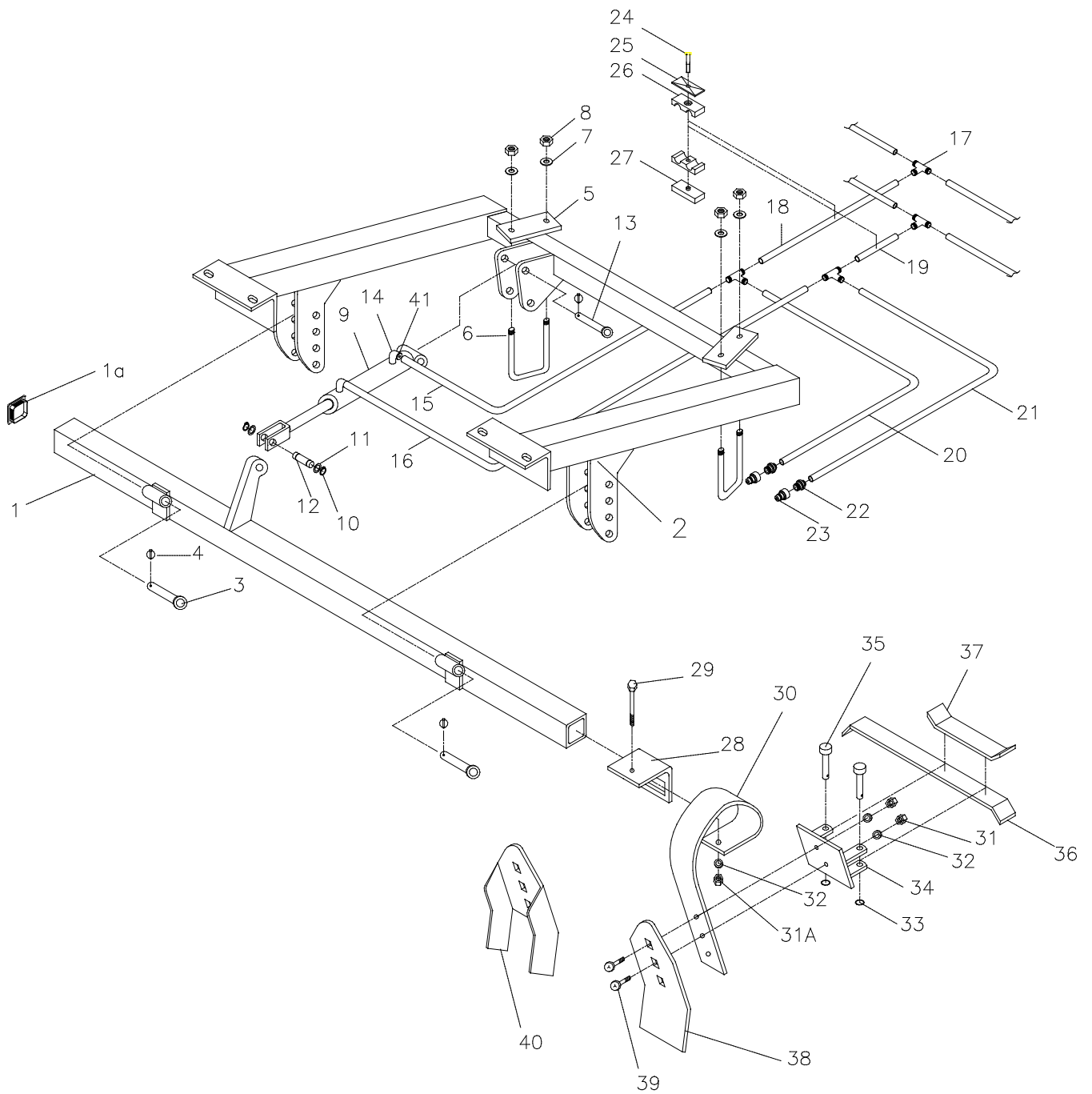

Pos.	Art. No.	Designation	4.5 m	5.4 m	6.3 m
1	633033020	Box section for tines	1	0	0
1	633043020	Box section for tines	0	1	0
1	633053020	Box section for tines	0	0	1
1A	690109202	Plast plug	2	2	2
2	633031000	Suspension for centre section	1	0	0
2	635041000	Suspension for centre section	0	1	0
2	635041005	Suspension for centre section after machin no. 342089		1	
2	633051000	Suspension for centre section	0	0	1
3	69525087F	Pin Ø25 L=87	2	2	2
4	0378200	Ring splitter-pin Ø4,5	3	3	3
5	670861100	Flange	2	2	2
6	690110101	U-Bolt M16x100x100x100	2	2	2
7	0272900	Disc Ø16	4	4	4
8	0264090	Nut M16	4	4	4
9	690200160	Cylinder 50/30x155	1	1	1
9e	690200045	Packing set 50/30 mm	-	-	-
10	691372020	Locking ring U 20 A2 Din 471	2	2	2
11	690115010	Washer Ø20/Ø28x1mm	2	2	2
12	69520046D	Pin Ø20 L=46	1	1	1
13	69520087F	Pin Ø20 L=87	1	1	1
14	690203006	Screw-in angle VA10LK 3/8"	2	2	2
15	690201015	Hydraulic hose 1/4" L=710	1	0	0
15	690201051	Hydraulic hose 1/4" L=250	0	1	1
16	690201015	Hydraulic hose 1/4" L=710	1	0	0
16	690201059	Hydraulic hose 1/4" L=350	0	1	1
17	690203015	Fastener T10	4	4	4
18	690201040	Hydraulic hose 1/4" L=1480	1	0	0
18	690201032	Hydraulic hose 1/4" L=1130	0	1	0



Pos.	Art. No.	Designation	4.5 m	5.4 m	6,3 m
18	690201032	Hydraulic hose 1/4" L=1130	0	0	1
19	690201040	Hydraulic hose 1/4" L=1480	1	0	0
19	690201053	Hydraulic hose 1/4" L=1260	0	1	0
19	690201053	Hydraulic hose 1/4" L=1260	0	0	1
20	690201060	Hydraulic hose 1/4" L=3000	1	0	0
20	690201044	Hydraulic hose 1/4" L=3460	0	1	0
20	690201038	Hydraulic hose 1/4" L=4000	0	0	1
21	690201060	Hydraulic hose 1/4" L=3000	1	0	0
21	690201005	Hydraulic hose 1/4" L=3300	0	1	0
21	690201006	Hydraulic hose 1/4" L=3800	0	0	1
22	690203003	½" screw-joint for quick-coupling (male)	2	2	2
23	690203001	Quick-coupling (male) ½"	2	2	2
24	690210213	Screw for double tube support (ø14, ø15, ø16, ø18)	5	5	5
25	690210211	Top plate for double tube support (ø14, ø15, ø16, ø18)	5	5	5
26	690210210	Tube support double ø14/ø14	10	10	10
27	690210212	Welding plate for double tube support (ø14, ø15, ø16, ø18)	5	5	5
28	633052200	Tine support	6	8	8
29	690103098	Bolt M12x110	6	8	8
30	0422145	Tine (10x80)	6	8	8
30a	633052000	Tine complete, with flat tine point	6	8	8
31	0264070	Self-locking nut M12	18	24	24
32	0272270	Disc ø12	18	24	24
33	0431975	Locking ring 30xø3	12	16	16
34	633055500	Tine fittings for locking system	6	8	8
35	69512040K	Pin Ø12,5 x 40	12	16	16
36	633055710	Long locking rod for locking system	10	14	14
37	633055700	Short locking rod fr locking system	2	2	2
38	633052100	Tine point (8x150)	6	8	8
39	0248670	Bolt M12 x 45	12	16	16
40	633052150	Tine point (crush breaker)	6	8	8
41	690207901	Restrictor 1 mm	1	1	1

**Spring-Board – Left Side Section**

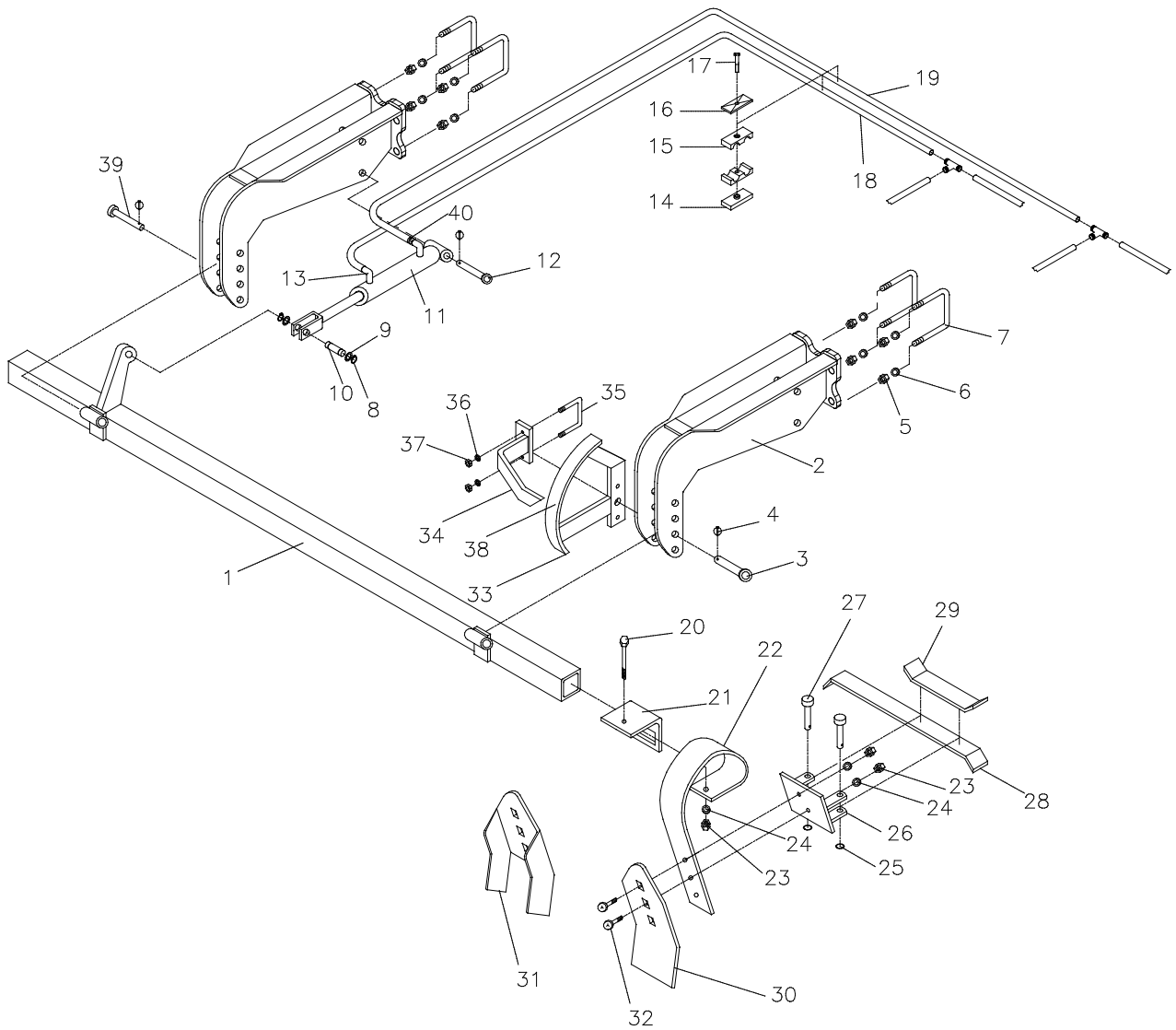

Pos.	Art. No.	Designation	4.5 m	5.4 m	6.3 m
1	633033010	Box section for tines (right)	1	0	0
1	633033030	Box section for tines (left)	1	0	0
1	633043010	Box section for tines (right)	0	1	0
1	633043030	Box section for tines (left)	0	1	0
1	635053010	Box section for tines (right)	0	0	1
1	635053030	Box section for tines (left)	0	0	1
2	633054500	Suspension for side section	4	4	4
2	633054520	Suspension for side section <b>(after 1th June 2010)</b>	4	4	4
3	69525095F	Pin Ø25 L=95	1	1	1
4	690134001	Ring splitter-pin Ø4,5	6	6	6
5	690113008	Self-locking nut M16	16	16	16
5	690113016	Self-locking nut M18 <b>(after 1th June 2010)</b>	16	16	16
6	0272900	Disc Ø16	16	16	16
6	690117015	Disc Ø18 <b>(after 1th June 2010)</b>	16	16	16
7	690110402	U-Bolt M16x160x80x160 mm	8	8	8
7	690110405	U-Bolt M18x160x80x160 mm <b>(after 1th June 2010)</b>	8	8	8
8	691372020	Locking ring U 20 A2 Din 471	4	4	4
9	690115010	Washer Ø20/Ø28x1mm	4	4	4
10	69520046D	Pin Ø20 L=46	2	2	2
11	690200160	Cylinder 50/30 x 155	2	2	2
11e	690200045	Packing set 50/30 mm	2	2	2
12	69520087F	Pin Ø20 L=87	2	2	2
13	690203006	Screw-in angle VA10LK 3/8"	4	4	4
14	690210212	Welding plate f/double tube support (ø14, ø15, ø16, ø18)	6	6	8
15	690210210	Tube support double ø14/ø14	12	12	16
16	690210211	Top plate for double tube support (ø14, ø15, ø16, ø18)	6	6	8
17	690210213	Screw for double tube support (ø14, ø15, ø16, ø18)	6	6	8
18	690201022	Hydraulikslange 1/4" left side section L= 3140 mm	1	0	0
18	690201005	Hydraulikslange 1/4" right side section L= 3300 mm	1	0	0
18	690201044	Hydraulikslange 1/4" left side section L= 3460 mm	0	1	0
18	690201048	Hydraulikslange 1/4" right side section L= 3610mm	0	1	0
18	690201048	Hydraulikslange 1/4" left side section L= 3610 mm	0	0	1



Pos.	Art. No.	Designation	4.5 m	5.4 m	6.3 m
18	690201006	Hydraulikslange 1/4" right side section L= 3800 mm	0	0	1
19	690201060	Hydraulikslange 1/4" left side section L= 3000 mm	1	0	0
19	690201060	Hydraulikslange 1/4" right side section L= 3000 mm	1	0	0
19	690201022	Hydraulikslange 1/4" left side section L= 3140 mm	0	1	0
19	690201005	Hydraulikslange 1/4" right side section L= 3300 mm	0	1	0
19	690201044	Hydraulikslange 1/4" left side section L= 3460 mm	0	0	1
19	690201048	Hydraulikslange 1/4" right side section L= 3610 mm	0	0	1
20	690103098	Bolt M12x110	12	14	16
21	633052200	Tine support	12	14	16
22	0422145	Tine (10x80)	12	14	16
22a	633052000	Tine complete	12	14	16
23	0264070	Selflocking nut M12	36	42	48
24	0272270	Disc Ø12	36	42	48
25	0431975	Locking ring 30xø3	24	28	32
26	633055500	Tine fitting for locking system	12	14	16
27	69512040K	Pin ø12.5x40	24	28	32
28	633055710	Long locking nut for locking system	10	12	14
29	633055700	Short locking nut for locking system	4	4	4
30	633052100	Tine point (8x150)	12	14	16
31	633052150	Tine point (crush breaker)	12	14	16
32	0248670	Bolt M12x45	24	28	32
33	635151000	Scale for depth control	1	1	1
34	635152000	Indicator for depth control	1	1	1
35	690110020	U-bolt M10x70x70x70 mm	1	1	1
36	0272260	Disc Ø10	2	2	2
37	0264060	Self-locking nut M10	2	2	2
38	698500018	Sticker for scale f/springboard	1	1	1
39	69525087F	Pin ø25 L=87	3	3	3
40	690207901	Restrictor 1mm	2	2	2

## Lights

### LED Light kit

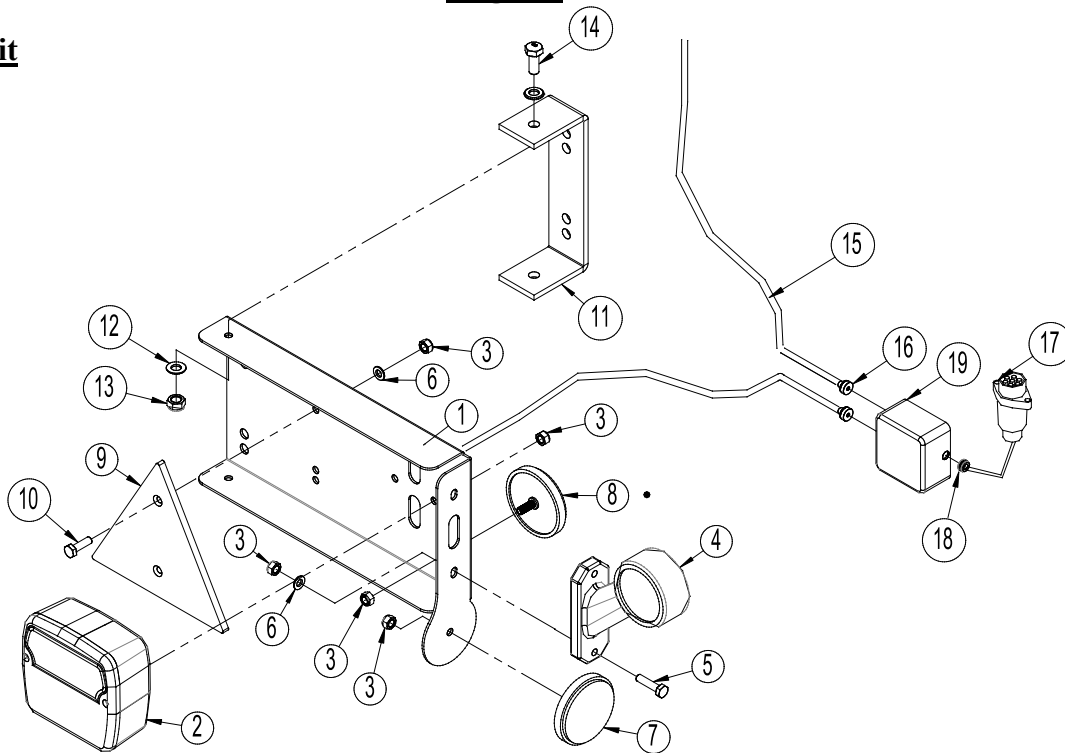

Pos.	Art. No.	Designation	Qty.
1	7357505	Lightbox (L)	1
	7357508	Lightbox (R)	1
2	7357504	Rear light	2
3	0264030	Locking nut M5	16
4	7357507	Marking lights (L)	1
	7357509	Marking lights (R)	1
5	0234340	Bolt M5x25	4
6	0272240	Facet plate Ø5	8
7	0656240	Reflex, yellow	2
8	0656250	Reflex, white	2
9	0521030	Reflex, red	2
10	0234330	Bolt M6x20	4
11	7357516	Bracket	2
12	0272250	Facetplate Ø8	16
13	0264050	Locking nut M8	8
14	0234750	Bolt M8x20	4
15	690160080	Cable 5 x 1mm <sup>2</sup> (Inform about length by ordering sparepart)	
16	7357545	Rutaseal nipple M20 8-12mm Grey RAL7001	2
17	690160070	Plug 7 poles DIN 72 577 – ISO 1724	1
18	7357546	Rubberbushing Nr. 38A Ø10/3 black	1
19	0520492	Junction box 105x105x60	1

Note: Check number and measurements of all cables before ordering the spare parts.

**Light kit: Electrical diagramme**

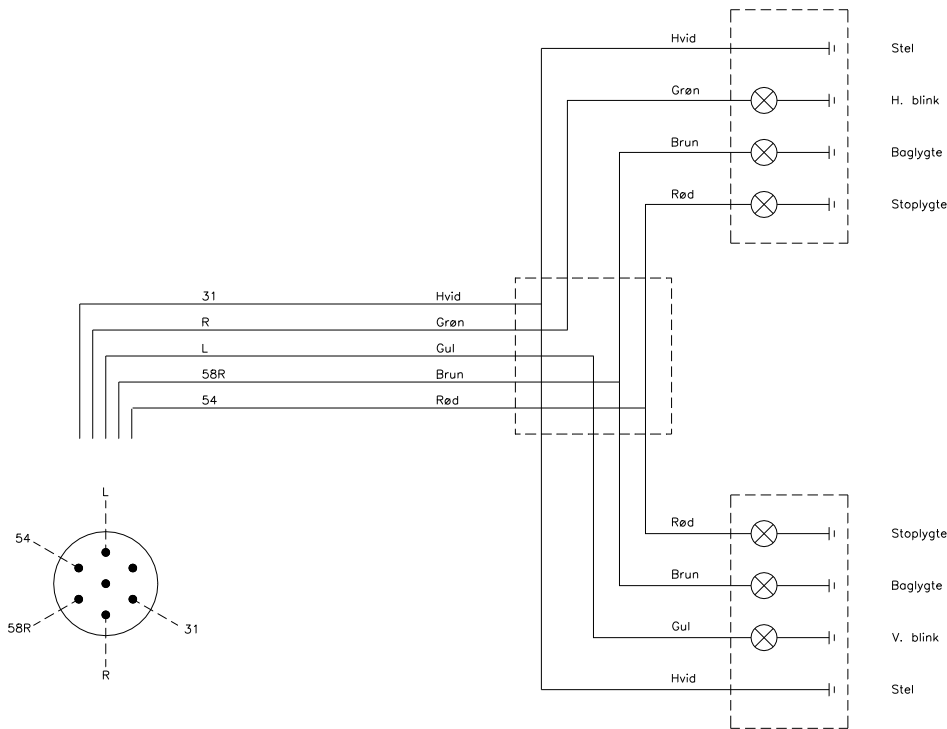

## Easy Change System

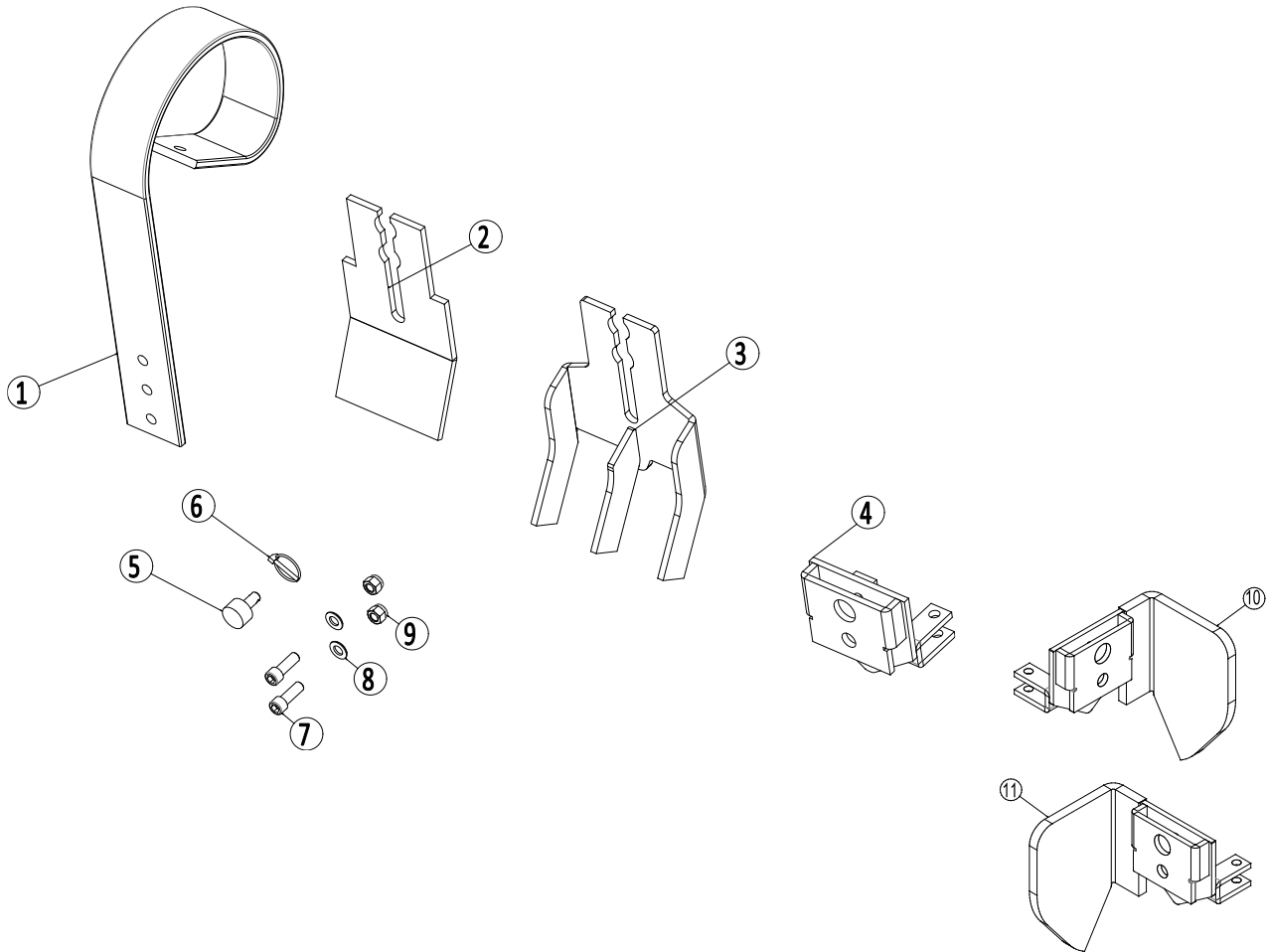

Pos.	Item no.	Designation	Qty.
1	0422145	Spring-Board tine	1
2	1170388	Flat wearing point - Easy Change	1
3	1170410	Slicing plate point w/3 tines – Easy-Change	1
4	1170389	Easy-Change bracket for transverse locking system	1
5	1170391	Locking pin	1
6	0378200	Ring split Ø4,5 mm	1
7	0227842	Insex DIN912 M12x35mm Fzb 8.8	2
8	0272270	Facet plate 12mm	2
9	0264070	Self-locking nut M12	2
10	1170806	Edge equipment, left	1
11	1170805	Edge equipment, right	1

as it looks  
As good as it looks  
As good as it looks  
As good as it looks  
As good as it looks

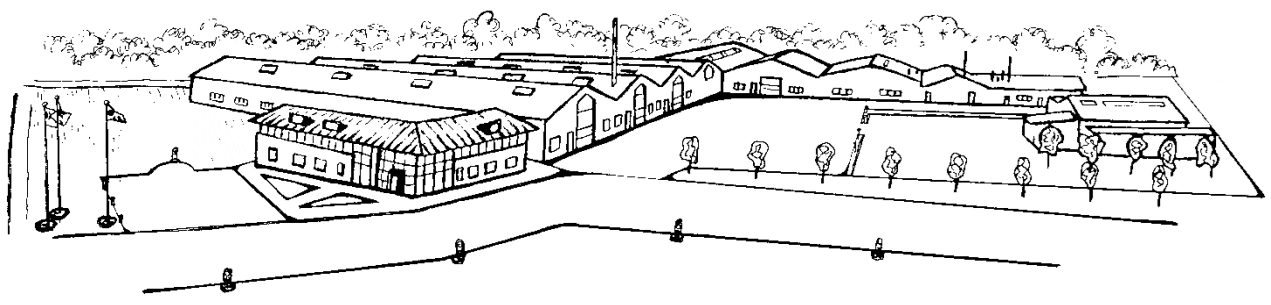

**The design is subject to modification without notice.**