



HE-VA

AS GOOD AS IT LOOKS!

AS GOOD AS IT LOOKS!

Käyttöohjeet
Varaosaluettelo
EU-Vaatimuksenmukaisuusvakuutus

AS GOOD AS IT LOOKS!

AS GOOD AS IT LOOKS!

AS GOOD AS IT LOOKS!

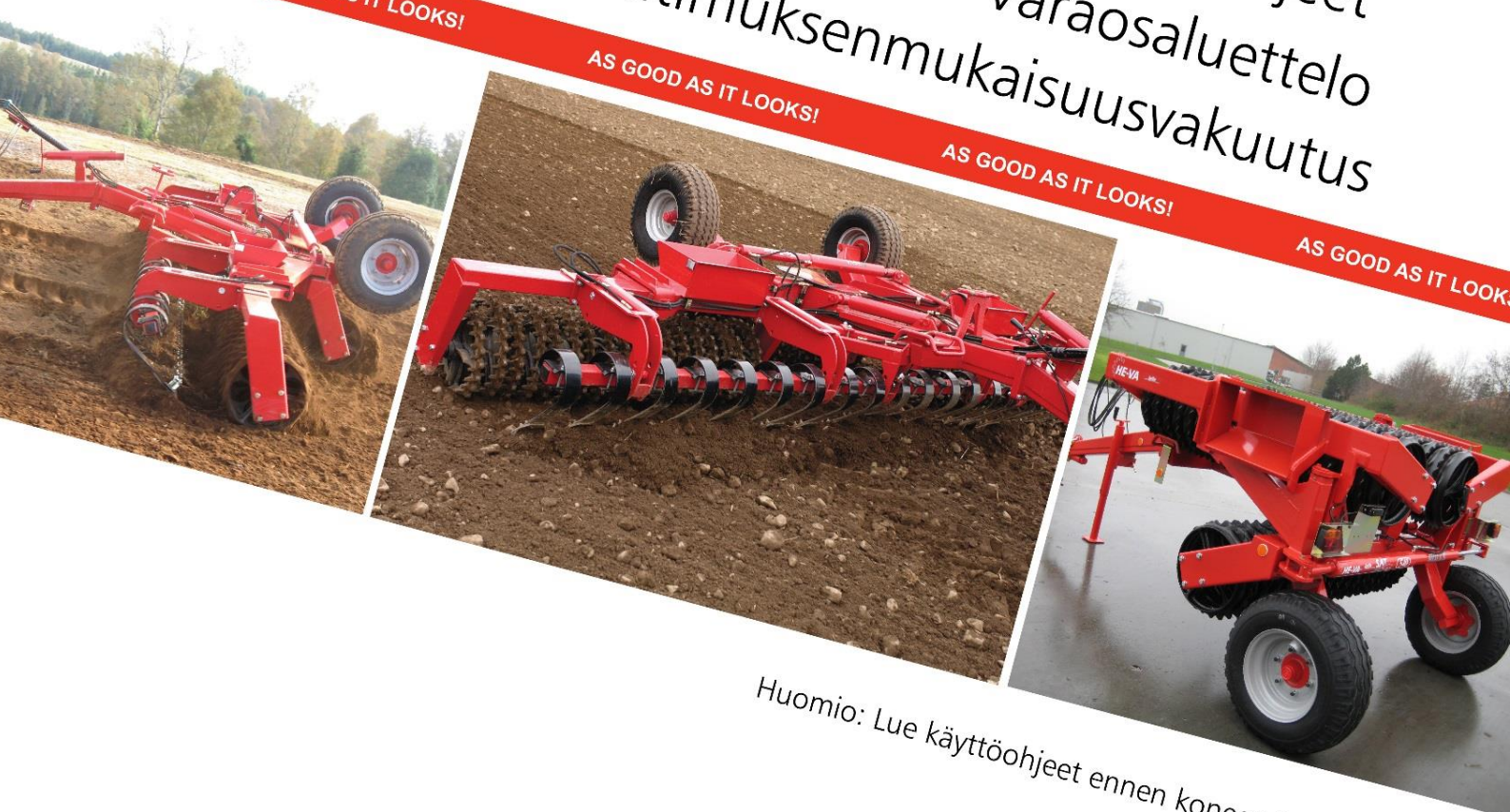

Huomio: Lue käyttöohjeet ennen koneen käyttöä.

Manual no. 8000344-04 071024

Tip-Roller

4,5 m - 5,4 m - 6,3 m

(yksinomainen 6,3 m kanssa 560 & 620 mm Cambridge,
550/600 mm Star rings, 550/600 mm Crosskill
& 550 & 600 mm 2D-Corrugated)



N. A. Christensensvej 34
DK-7900 Nykøbing Mors
Tel: 97724288
Fax: 97722112
www.he-va.com

Sisällysluettelo

EY-VAATIMUKSEN MUKAISUUSVAKUUTUS	4
Description of the machine	5
Delivery Check	5
Transport Brackets	5
Specifications	6
Technical specifications	6
Operating Instructions	6
Attachment	6
Transport	7
When rolling	8
Huolto	8
Lubrication chart	9
Safety at the Tip-Roller	10
Safety Instructions, regarding Hydraulic System	11
Disposal	11
Reklamaatiot	11
Markings on the machine	12
Safety – and other markings on the machine	12
Notes	13
Jyrän varaosaluettelo	14
Runko, ennen toukokuuta 2010	14
Runko, alk. toukokuu 2010	16
Pyörärunko	18
Sivulohko	19
Pyörärunko Ø620 jyräkiekot, koneen nrosta 342089 alk.	20
Sivulohkon kiinnitys, Ø620 jyräkiekot, koneen nrosta 342089 alk.	21
Jyrälohko	22
Jyrähydrauliikka	24
Jousilata	26
Jousiladan sylinterien asennus	26
Jousiladan keskilohko	27
Jousilata – Vasen lohko	30
Valot	33
LED Valosarja	33
Valosarja: Sähkökaavio	34
Easy Change System	35



EY-VAATIMUKSEN MUKAISUUSVAKUUTUS

EY-konedirektiivin 2006/42/EY mukaisesti
joka on voimassa alkaen 29. joulukuuta 2009

HE-VA ApS
N. A. Christensensvej 34,
DK-7900 Nykøbing Mors

vakuuttaa täten, että alla mainittu kone on
EY-direktiivin 2006/42/EY mukainen.

Vakuutus koskee seuraavia tuotteita:

Tip – Roller 4,5m – 5,4m – 6,3m

Nykøbing 29. joulukuuta 2009



Villy Christiansen

Allekirjoittaja vastaa myös yllä mainitun koneen teknisistä tiedoista.

Description of the machine

The Tip-Roller is a 3-sectioned hydraulic, wheel mounted roller. Tip-Roller is to be used for packing the top soil, to maintain the content of moisture in it, and to eliminate not solid stones from the surface of the cultivated area.

The roller sections has an independent suspension. Side sections are center-mounted in an intermediate joint, connecting the side sections to the wheel frame, which gives the sections a perfect adaption to the ground in uneven areas. The changing between transport- and work position is by hydraulic force. The roller has a low and compact transport position with a width of 2,2 or 2,42 meters.

Read the manual before operating the roller and strictly follow the safety instructions.

Delivery Check

Check the roller for any damages. Check the hydraulic hoses for cuts and squeezing damages. Check also the other hydraulic components, are not damaged during transport.

Check that the frame construction has not been damaged. You should also check that the roller blocks have not been exposed to impacts, which may have damaged the cast roller rings or the double-sealed ball bearings.

Finally check that the transport wheels are tightened and OK.

Check the air pressure in the tyres according to Technical Specifications chart next page

Instructions for unloading and final assembly

In order to minimize the roller's space during transport, the roller is supplied partially separated from the factory. If the machine is delivered unassembled, it must therefore be completely installed first.

Transport Brackets

At delivery the machine is mounted with brackets for hoisting gear, which is not painted.

These brackets is for attachment of chains or straps, when loading or unloading the machine from the transport vehicle, and they must be dismantled before use.

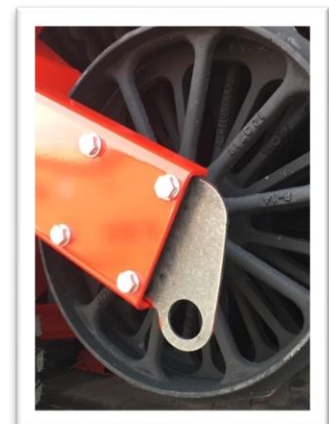

Specifications

3-section hydraulic wheel-mounted field roller with free movement in all sections. The roller is delivered with a working width of 4,5 - 5,4 - 6,3 meters, respectively, with 6 different ring types: cambridge- cam- star- 2D wave- cross-kill ring and rigid roller.

Technical specifications

Work width m.	4,5	5,4	6,3
Width in workposition m.	4,75	5,64	6,55
Length m.	4,0	4,0	4,95
Transport width m.	2,2	2,2	2,42
Transport height m. w / without add.equipment	1,62/2,44	1,62/2,44	1,72 / 2,54
Weight kg basic machine depending on ring type	1.510 - 2.810	1.880 - 3.240	2.110 - 4.190
Wheel size	10.0/75x15,3 - 10 PLY	11.5/80x15.3 – 14 PLY	400/60x15,5 - 16 PLY
Max tyre pressure bar/psi	3,9/57	4,7/68	4,3/62
Oil pressure	min. 150 bar		
Hydraulic outlets	2 pc double function		
Quick couplings, standard	Sterling type E 402		
Hydraulic oil	Hydro Texaco HD32, Specification DIN 51524-3 / ISO 11158 L-HV		

Operating Instructions

Attachment

On delivery the roller is in transport position. When the roller is attached, check that the towing hook height is 500-600 mm. Reverse the tractor, put in and **secure** the draw bolt.

Attention: Check that the towing eye fits the height of the tractors drawbar

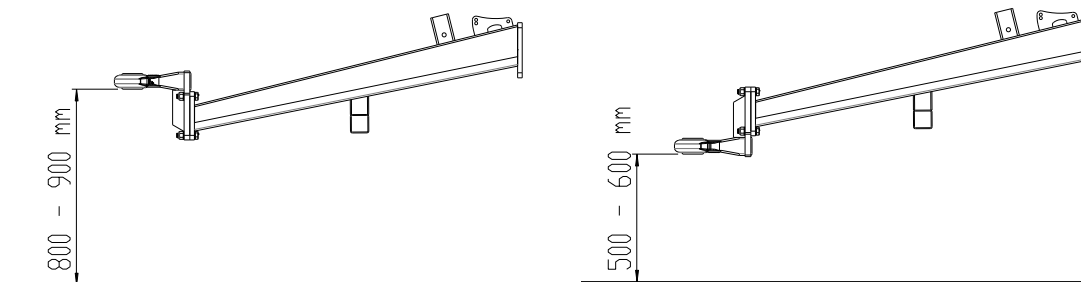

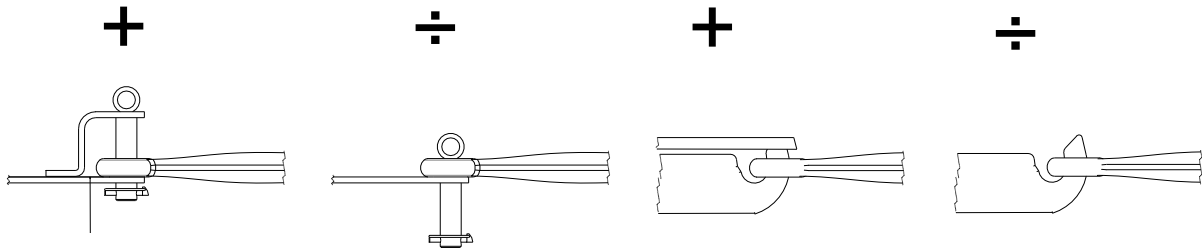

Raise the support leg and place it in the transport fittings on top of the drawbar. Now fit the four hydraulic hoses.

The hoses for the tip cylinder are provided with **red** tie strap.

The hoses for the wing cylinder are provided with **blue** tie strap.

Important:

Check that the male end mounted by the factory fits the female end of the quick couplings of the tractor.
 Now pressurise the tip cylinder (red) so that the side sections are tipped free of the transport fittings.
 Then the wing cylinder (blue) is pressured so that the wings are turned as much back as possible.
 Now relieve the pressure on the tip cylinder, and the roller will tip forward down to working position. When the bottom has been reached, let go of the hydraulic handle and the roller is ready for use.

Transport

At change-over for transport, the roller is tipped totally backward by pressurising the tip cylinder. Now pressurise the wing cylinder so that the side sections turn forward, towards the stop on the transport fittings of the drawbar.

When both sides lie in parallel with the drawbar, they are lowered down into the transport fittings by unpressurising the tip cylinder. Then relieve the pressure on all hydraulic hoses, and the roller is ready for transport.

INSTRUCTIONS FOR TRANSPORT AT PUBLIC ROADS:

Before transport at public roads, make sure that the attachment of the implement to the tractor, is in accordance with the local rules and regulations in force (permitted total weight, permitted axel load, transport width, lights and warning signs).

FRONT AXEL LOAD:

When the implement is attached and at maximum load, the tractors driving properties must be ensured. Check that the front axel is sufficiently loaded. The front axel load must be at least 20% of the tractors weight. Permitted axel load and total weight for the tractor must be respected.

NB! The driving, controlling and braking properties are affected by the attached implement

When rolling

Speed: max. 10 km/h.

When turning, drive in wide curves as far as possible. The turning should be performed no sharper, than all roller rings are still rotating forward.

Only lower the wheels when making ready for transport position.

Do not drive over any large stones, which are not moveable.

Huolto

- A. N. 10 käyttötunnin jälkeen pyörien mutterit, kuulalaakerit ja lukitusrenkaat kiristetään. Letkut, liitokset ja sylinterit tarkistetaan, ettei niissä ole vuotoja. Kiristys tehdään tarvittaessa.

Enimmäiskiristysmomentit according to ISO 898-1 Nm, öljyllä voidellut kierteet			
Metriset kierteet	Lujuusluokka 8.8	Lujuusluokka 10.9	Lujuusluokka 12.9
M10x1,5	38	54	63
M12x1,75	66	95	110
M14x2,0	105	150	176
M16x2,0	164	235	274
M18x2,5	233	323	377
M20x2,5	331	458	535
M22x2,5	450	622	727
M24x3,0	572	791	925
Pyörän mutteri M18x1,5 hienokierre		360 Nm	
Pyörän mutteri M22x1,5 hienokierre		550 Nm	

Controle tightening:

- flange for towing eye, 6 bolts M16 in quality 10.9
- flanges between drawbar and the rear drawbar 6 or 12 bolts M16 in quality 10.9

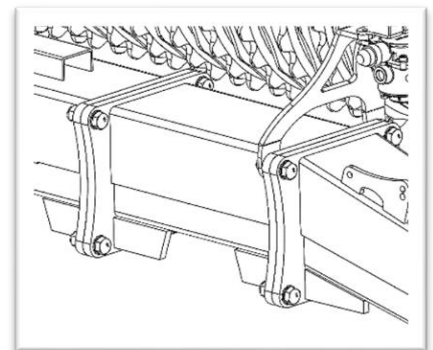
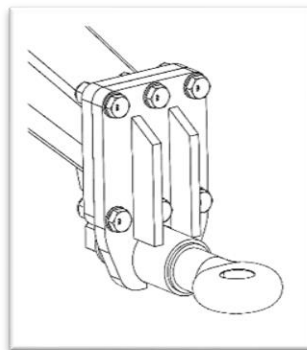

- B. N. 10 käyttötunnin välein voidellaan kaikki lohkojen liikkuvat osat sekä lohkosylinterien kolme voitelukohtaa. N. 30 käyttötunnin välein voidellaan nosto- ja laskusylinterin tapit sekä rungon kolme tappia.
- C. Käyttökauden jälkeen jyrä puhdistetaan ja voidellaan rasvalla ja öljyllä. Sivele sylinterien männänvarret rasvalla or in conservation oil

Lubrication chart

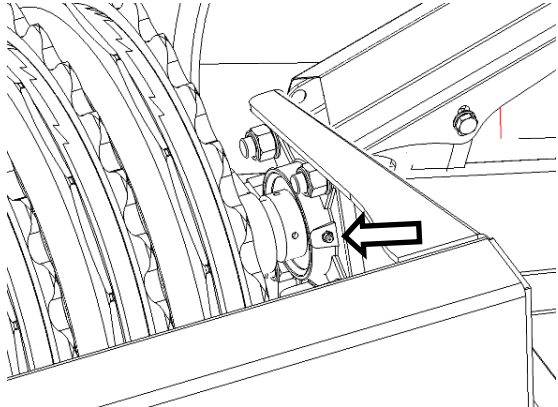
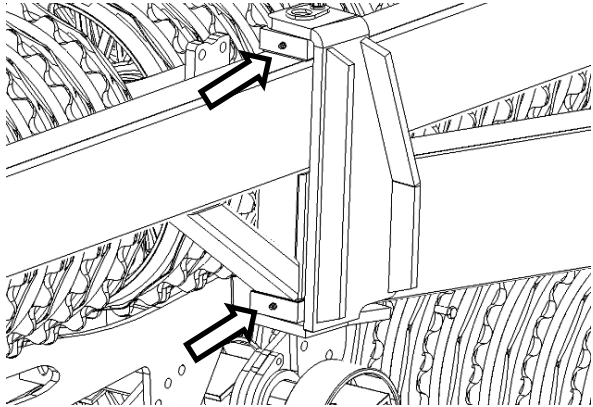
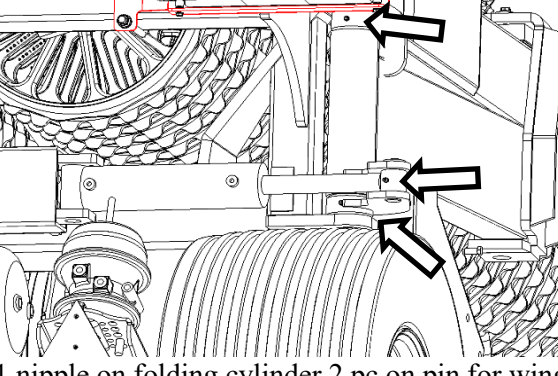
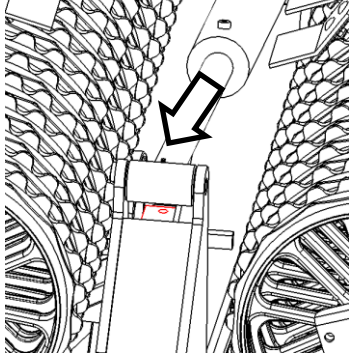
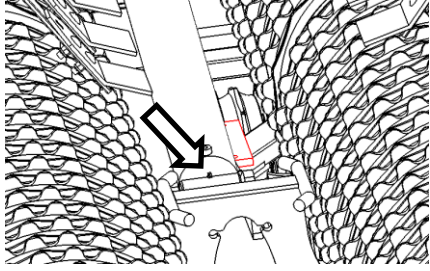
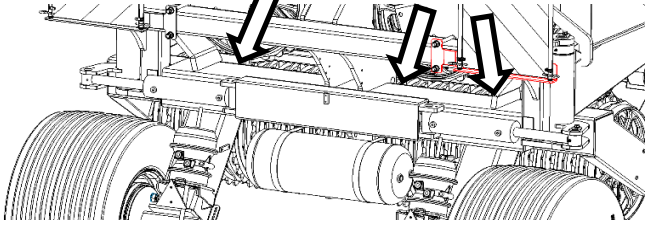
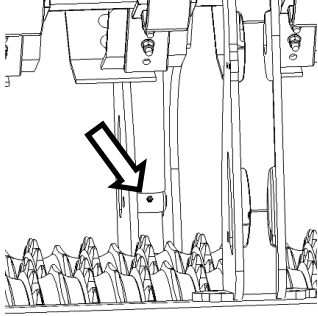
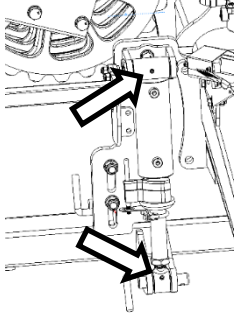
 <p>All ends on roller blocks, twice each season and after wash</p>	 <p>2 nipples on wings pivot joints 10 hours</p>
 <p>1 nipple on folding cylinder 2 pc on pin for wings 10 hours</p>	 <p>Rod end of tip cylinder 30 hours</p>
 <p>Cylinder end of tip cylinder 30 hours</p>	 <p>3 nipples on pivot joint between rear drawbar and wheel frame 30 hours</p>
 <p>1 nipple on each Spring-Board cylinder 10 hours</p>	 <p>2 nipples at track eradicator cylinder 10 hours</p>

Safety at the Tip-Roller

Do not operate the machine, **if any people¹** are at risk in **the dangerous area.²**

When persons are at risk in the dangerous area (e.g. when doing adjustments, maintenance or connect or disconnecting), the following points must be met:

- Lower the machine on solid ground.
- Hydraulic must be relieved.
- Tractor must be turned off, and the key removed.
- Driver must be aware of, when operating that there is no persons at risk in the dangerous area.
- He-Va cannot be held responsible for any falling accidents due to washing lubrication and other maintenance tasks
- By the time tires will become tender and explosion danger can occur, when transporting or when controlling tire pressure
- Drive carefully when going from road to paddock and opposite. Be aware of ditches along the road and holes in dirt roads, because gravity point is reasonable high in transport position. Specially when additional equipment is mounted
- The machine must not be operated by persons who have not been properly instructed or trained

Most accidents when operating the machine, transporting and doing maintenance occurs, when avoiding the most simple safety regulations.

For this reason, it is of highest importance, that any person who is operating the machine, strictly follows the safety regulations and other instructions, which belongs the machine.

The machine must only be operated, maintained and fixed by persons, who is confidential with and skilled for this work and is aware of moments of danger, which can occur.

ATTENTION!! Rotating parts and loose in a loose condition, is a dangerous combination.

IMPORTANT!! It is strictly prohibited for any person to take place on the frame of the machine, when it is either operating or the tractor is idling.

¹ People at risk: Any person, who is completely or partially in the dangerous area.

² Dangerous area: At the machine and underneath it, and in distance of 4 m from it.

Safety Instructions, regarding Hydraulic System

1. The highest allowable pressure, is 225 bar.
2. It is recommended to mark the hydraulic connections between the implement and tractor, to avoid incorrect operation!
3. When checking for hydraulic leaks, suitable safety gear must be used due to danger. (Safety goggles , gloves, etc.)
At high pressure, Hydraulic oil can penetrate the skin and cause serious injuries.
At injuries, consult a doctor immediately. **RISK OF INFECTION!**
4. Before any work at the hydraulic system, the implement must be lowered to solid ground.
Pressure must be relieved, engine stopped, and ignition key removed.
5. Check the hydraulic hoses on a regular basis, however, every six months as a minimum due to any cracks, wear and tear, etc. Replace any defective hoses immediately.
6. Hydraulic hoses last for no more than 5 years.
New hydraulic hoses must be identical to the manufacturer's specifications.

Disposal

When, after many years of use, the machine is to be regarded as end-of-life, it must be disposed of to a registered and approved product dealer. This will carry out the statutory discharge and disposal of hydraulic oil, as well as sorting materials for further processing for recycling.

Reklamaatiot

Reklamaatiokorjaukset tehdään jälleenmyyjän korjaamolla normaalin työajan puitteissa. Ellei toimenpidettä voi tehdä normaalin työajan puitteissa on ylityöstä maksettava korvaus.
Reklamaatiokorjaukseen tuotavat koneet on puhdistettava ennen toimitusta.

Markings on the machine

Several markings are located at your machine, which contains **safety regulations** and other instructions to inform about correct operating.

Please read these instructions carefully, and make the driver aware about the markings and **safety regulations** in this Operating Instructions. Keep the markings clean and readable. If they are not, they must be replaced.

Safety – and other markings on the machine

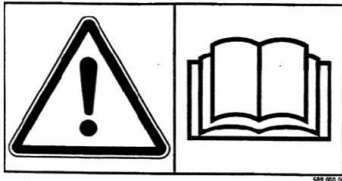

Study the Operating Instructions thoroughly before any operation of the machine and observe all safety instructions.

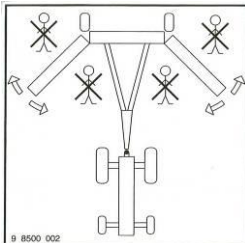

Take care that no persons are within the machine's hazardous area during the unfolding and folding procedure.



Plate with number and year of manufacture.

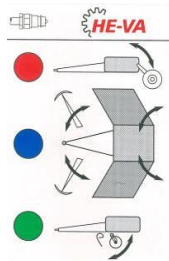

Identification marks for the hydraulic system:

Red: Tip cylinder

Blue: Folding cylinder

Green: Additional equipment



Tighten up the bolts regularly. If this is not performed, our warranty obligations will no longer apply.

Notes

--	--

Jyrän varaosaluettelo

Runko, ennen toukokuuta 2010

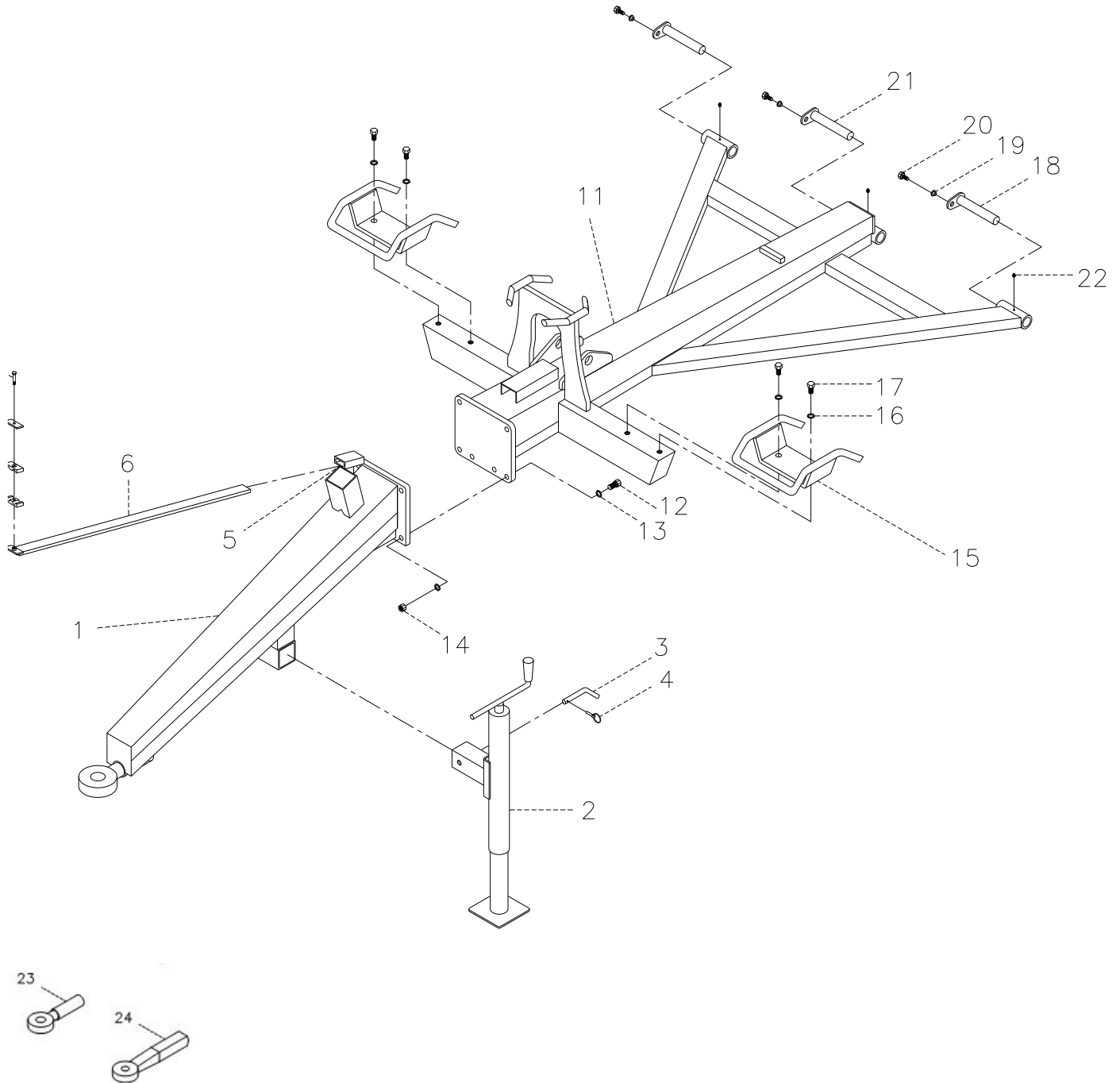

Kohta	Osanumero	Nimike	4,5 m	5,4m	6,3m
1	630751000	Eturunko (Tanska)	1	1	1
1	630876000	Eturunko (Saksa)	1	1	1
2	690141100	Seisontatuki 3500 kg (Tanska)	1	1	1
2	690141101	Seisontatuki 3500 kg (Saksa)	1	1	1
3	69516094A	Tappi ø16	1	1	1
4	0377400	Sokka ø4 mm	1	1	1
5	0235040	M10x25 pultti	2	2	2
6	630771200	Hydr.letkujen pidike	1	1	1
7	690210212	Letkupidikkeen (ø14, ø15, ø16, ø18) aluslevy	1	1	1
8	690210210	Letkupidike ø14/ø14	2	2	2
9	690210211	Letkupidikkeen (ø14, ø15, ø16, ø18) päällyslevy	1	1	1
10	690210213	Letkupidikkeen (ø14, ø15, ø16, ø18) ruuvi	1	1	1
11	630715000	Takarunko	1		
11	630725000	Takarunko		1	
11	630755000	Takarunko			1
12	690103275	Pultti M16x65 10.9	6	6	6
13	0272900	Aluslevy Ø16	12	12	12
14	0264090	Lukkomutteri M16	6	6	6
15	630530300	Kuljetustuki	2	2	2
15	630530400	Kuljetustuki Ø510 mm	2	2	2
16	0272900	Aluslevy Ø16	4	4	4
17	690103124	Pultti M16x35	4	4	4
18	69530145G	Tappi Ø30 P=145	2	2	2
19	630532600	Tapin kannan lukkoaluslevy	3	3	3
20	690101101	Pultti M12x25	3	3	3
21	69530175G	Tappi Ø30 P=175	1	1	1
22	0432510	Voitelunippa M8	3	3	3
23	690141211	Vetosilmukka (Tanska)	1	1	1
24	690105003	Vetosilmukka (Saksa)	1	1	1

Runko, alk. toukokuu 2010

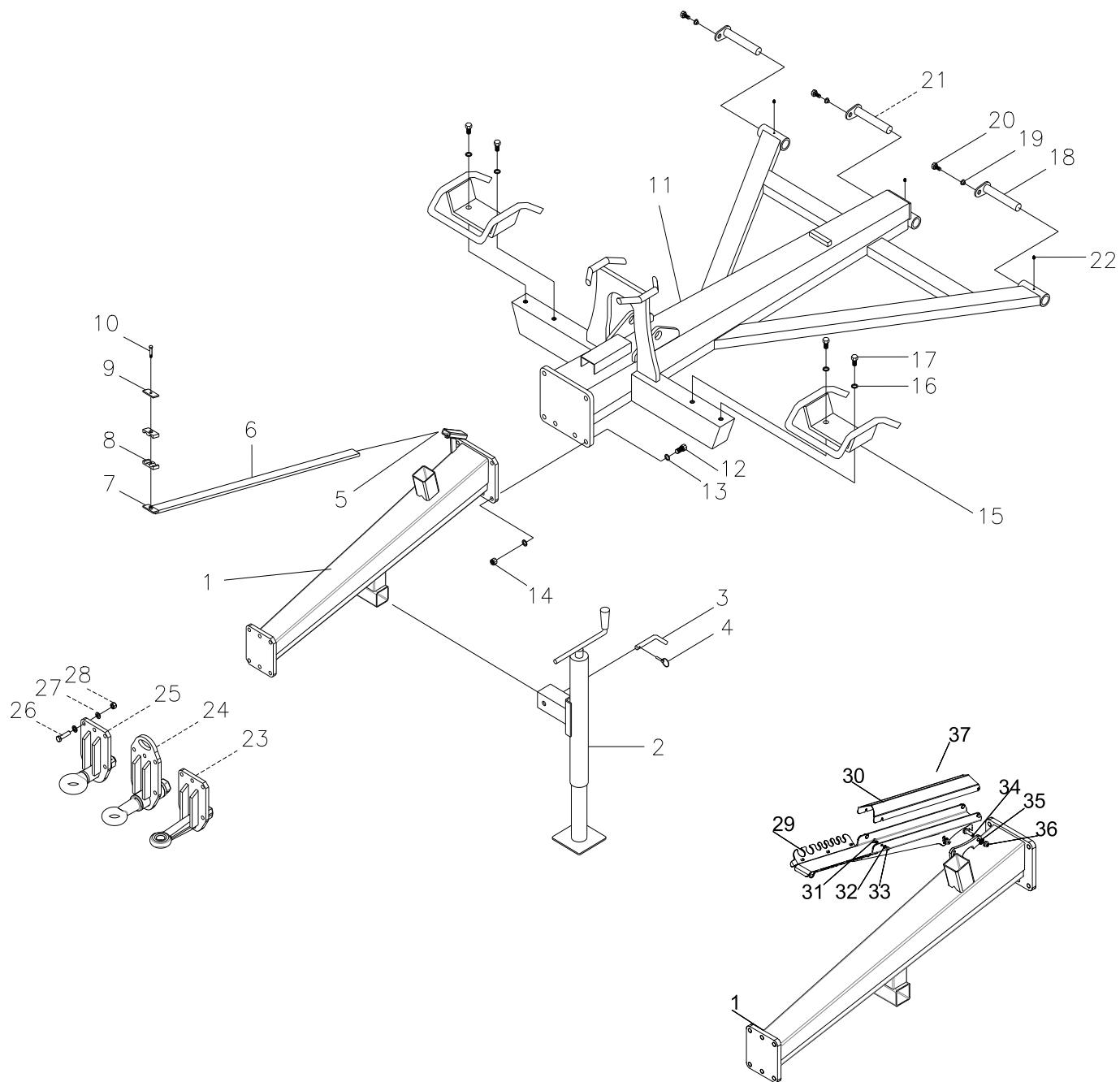

Kohta	Osanumero	Nimike	4,5 m	5,4m	6,3m
1	630757032	Eturunko	1	1	1
2	690141100	Seisontatuki 3500 kg	1	1	1
3	69516094A	Tappi ø16	1	1	1
4	690133005	Sokka ø4 mm	1	1	1
5	690103075	M10x25 pultti	2	2	2
6	630771200	Hydr.letkujen pidike	1	1	1
7	690210212	Letkupidikkeen (ø14, ø15, ø16, ø18) aluslevy	1	1	1
8	690210210	Letkupidike ø14/ø14	2	2	2
9	690210211	Letkupidikkeen (ø14, ø15, ø16, ø18) päällyslevy	1	1	1
10	690210213	Letkupidikkeen (ø14, ø15, ø16, ø18) ruuvi	1	1	1
11	630715000	Takarunko	1		
11	630725000	Takarunko		1	
11	630755000	Takarunko			1
11	630536200	Takarunko, Ø620 jyräkiekkoihin saakka koneen nrosta 342089 alkaen	1		
11	630546200	Takarunko, Ø620 jyräkiekkoihin saakka koneen nrosta 342089 alkaen		1	
12	690103275	Pultti M16x65 10.9	6	6	6
13	0272290	Aluslevy Ø16	12	12	12
14	0264090	Lukkomutteri M16	6	6	6
15	630530300	Kuljetustuki	2	2	2
15	630530400	Kuljetustuki Ø510 mm	2	2	2
16	0272900	Aluslevy Ø16	4	4	4
17	690103124	Pultti M16x35	4	4	4
18	69530145G	Tappi Ø30 P=145	2	2	2
19	630532600	Tapin kannan lukkoaluslevy	3	3	3
20	690101101	Pultti M12x25	3	3	3
21	69530175G	Tappi Ø30 P=175	1	1	1
22	0432510	Voitelunippa M8	3	3	3
23	630757013	Vetolaite täyd. Ø40 kiinteä M16 pultit	1	1	1
23a	690105003	Erill. vetosilmukka, Ø40 kiinteä			
24	630757025	Vetosilmukka täyd. Ø50, pyörivä, yht.sopiva M16 pultit	1	1	1
24a	690105004	Erill. vetosilmukka, Ø50, pyörivä, yht.sopiva			
25	630757028	Vetolaite täyd. Ø50 pyörivä M16 pultit	1	1	1
25a	690141211	Erill. vetosilmukka, Ø50, pyörivä			
26	690103275	Pultti M16x65 10.9	6	6	6
27	0272290	Aluslevy Ø16	12	12	12
28	0264090	Lukkomutteri M16	6	6	6
29	7345001	Parking devise for hose 8 places	1	1	1
29	7345002	Parking devise for hose 14 places	1	1	1
30	7345003	Cover for parking devise	1	1	1
31	0246060	Bolt	4	4	4
32	0272240	Facetted disc 6mm	4	4	4

Kohta	Osanumero	Nimike	4,5 m	5,4m	6,3m
33	0264040	Self-locking nut M6, DIN985	4	4	4
34	0235360	Bolt M12x40mm,8.8 fzg	2	2	2
35	0272270	Facetted disc Ø12	4	4	4
36	0264070	Self-locking nut M12 DIN985	2	2	2
37	7345010	Complete parking device for hoses 8 places (pos 33-40)			
37	7345019	Complete parking device for hoses 14 places (pos 33-40)			

Pyörärunko

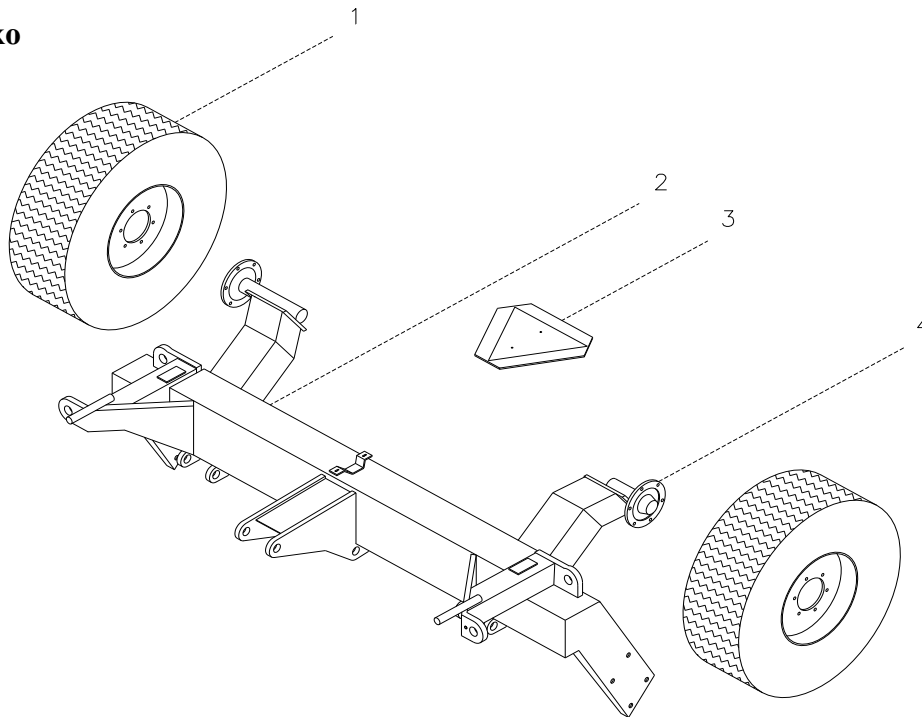

Kohta	Osanumero	Nimike	4,5 m	5,4m	6,3m
1	690141310	Pyörä 10.0/75 x 15.3 10 PLY	2	2	2
1	690141215	Pyörä 11.5/80x15.3 - 14pr koneen nrosta 349836 alkaen			2
2	630712000	Keskirunko	1		
2	630722000	Keskirunko		1	
2	630752000	Keskirunko			1
3	690142001	Hitaan ajoneuvon kolmio	1	1	1
3a	0233860	Pultti M5x20	2	2	2
3b	0264030	Mutteri M5	2	2	2
3c	0272230	Aluslevy Ø5	2	2	2
4	690141025	Napa 7050.6-M18/161-205 1700 kg	2	2	2
4a	690141039	Navan pultti M18x1.5x49	12	12	12
4b	0396470	Napamutteri M18	12	12	12
4f	0395260	Navan suojuus Ø62	2	2	2

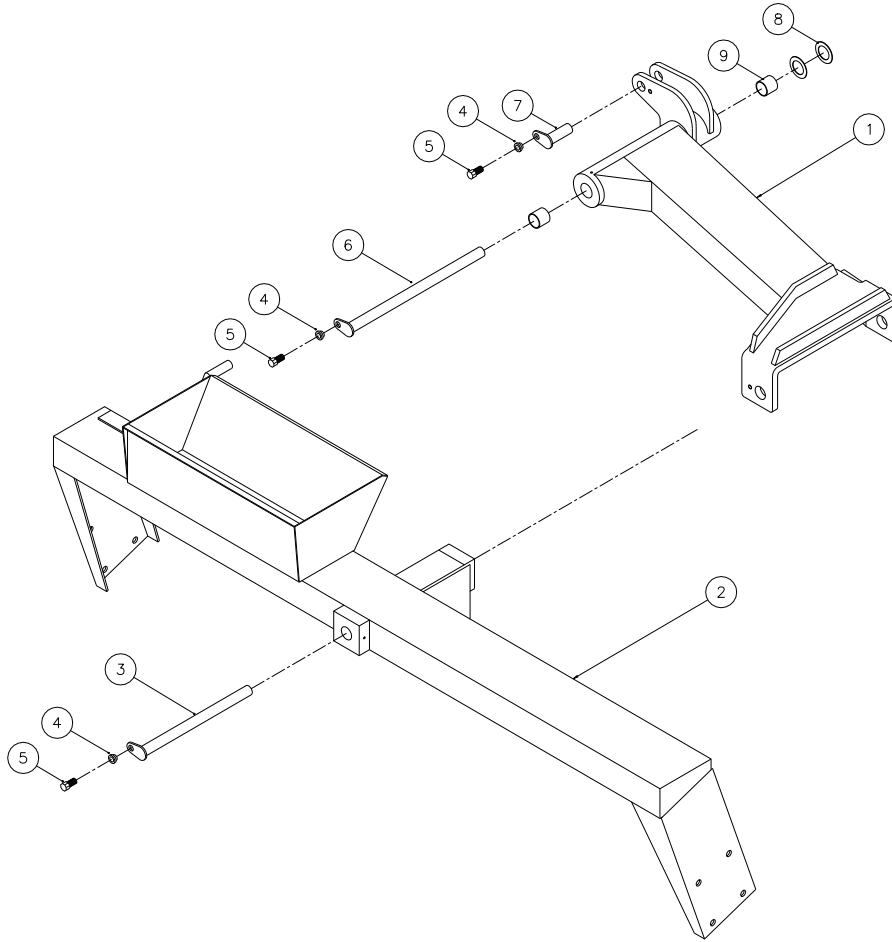
Sivulohko

Kohta	Osanumero	Nimike	4,5 m	5,4m	6,3m
1	630713011	Oikea kannatin	1		
1	630723011	Oikea kannatin		1	
1	630753007	Oikea kannatin			1
1	630713010	Vasen kannatin	1		
1	630723010	Vasen kannatin		1	
1	630753003	Vasen kannatin			1
2	630714000	Vasen sivulohko	1		
2	630724000	Vasen sivulohko		1	
2	630754000	Vasen sivulohko			1
2	630714100	Oikea sivulohko	1		
2	630724100	Oikea sivulohko		1	
2	630754100	Oikea sivulohko			1
3	69440425G	Tappi Ø40 P=425	2	2	2
4	630532600	Tapin kannan aluslevy	6	6	6
5	690101101	Pultti M12x25	6	6	6
6	69440525G	Tappi Ø40 P=525	2	2	2
7	69430090G	Tappi Ø30 P=90	2	2	2
8	690140714	Tukilevy Ø42/Ø66x1,5	4	4	4
9	0475100	Holkki Ø40/Ø44 P=40			4

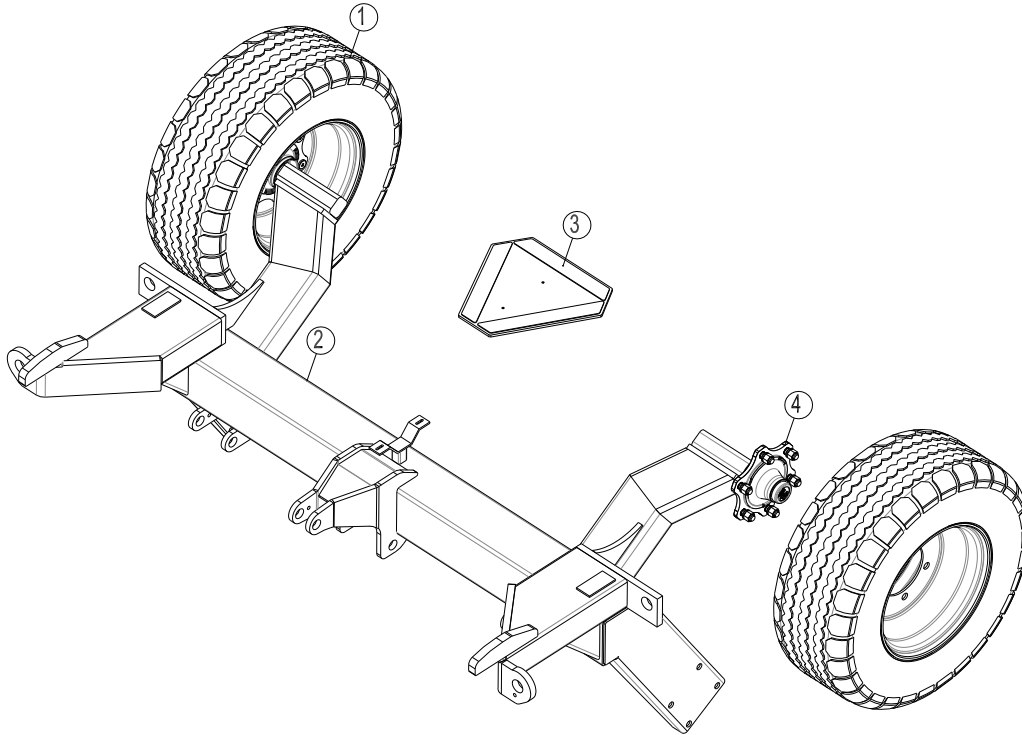
Pyörärunko Ø620 jyräkietot, koneen nrosta 342089 alk.

Kohta	Osanumero	Nimike	4,5 m	5,4m
1	690141310	Pyörä 10.0/75 x 15.3 10 PLY	2	2
2	630536300	Keskirunko	1	
	630546300	Keskirunko		1
2	630536325	Keskirunko sivulohkon lukituksella	1	
	630546325	Keskirunko sivulohkon lukituksella		1
2a	630536521	Sivulohkon lukituksen lukitustappi Ø35 P=340	2	2
2b	690134010	Lukitustapin sokka	2	2
3	0521010	Hitaan ajoneuvon kolmio	1	1
3a	0233860	Pultti M5x20	2	2
3b	0264030	Mutteri M5	2	2
3c	0272230	Aluslevy Ø5	2	2
4	0395440	Napa M18/160-205 1700 kg	2	2
4a	690141039	Navan pultti M18x1.5x49	12	12
4b	0396470	Napamutteri M18	12	12
4f	0395436	Navan suojuus Ø62	2	2

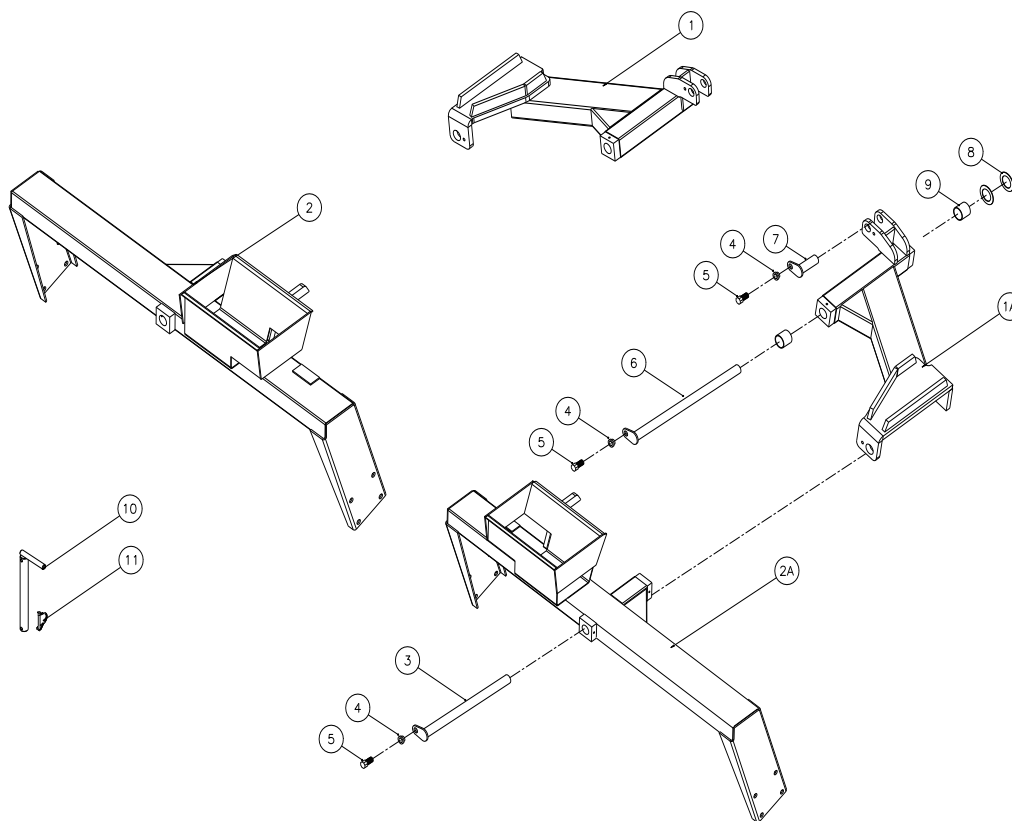
Sivulohkon kiinnitys, Ø620 jyräkiekot, koneen nrosta 342089 alk.

Kohta	Osanumero	Nimike	4,5 m	5,4m
1	630536410	Oikea kannatin	1	
1	630536425	Oikea kannatin, lohkon lukituksella		
1	630546410	Oikea kannatin		1
1	630546425	Oikea kannatin, lohkon lukituksella		
1A	630536400	Vasen kannatin	1	
1A	630536420	Vasen kannatin, lohkon lukituksella		
1A	630546400	Vasen kannatin		1
1A	630546420	Vasen kannatin, lohkon lukituksella		
2	630536510	Oikea sivulohko	1	
2	630546510	Oikea sivulohko		1
2	630536525	Oikean sivulohkon nivel, lohkon lukituksella	1	
2	630546525	Oikean sivulohkon nivel, lohkon lukituksella		1
2A	630536500	Vasen sivulohko	1	
2A	630546500	Vasen sivulohko		1
2A	630536515	Vasemman sivulohkon nivel, lohkon lukituksella	1	
2A	630546515	Vasemman sivulohkon nivel, lohkon lukituksella		1
3	69440425G	Tappi Ø40 P=425	2	2
4	630532600	Tapin kannan aluslevy	6	6
5	690101101	Pultti M12x25	6	6
6	69440525G	Tappi Ø40 P=525	2	2
7	69430090G	Tappi Ø30 P=90	2	2
8	690140714	Tukilevy Ø42/Ø66x1,5	4	4
9	690140715	Holkki Ø40/Ø44 P=40	4	4
10	630536521	Sivulohkon lukituksen tappi Ø35 P=340	2	2
11	690134010	Sokka 8mm	2	2

Jyrälohko

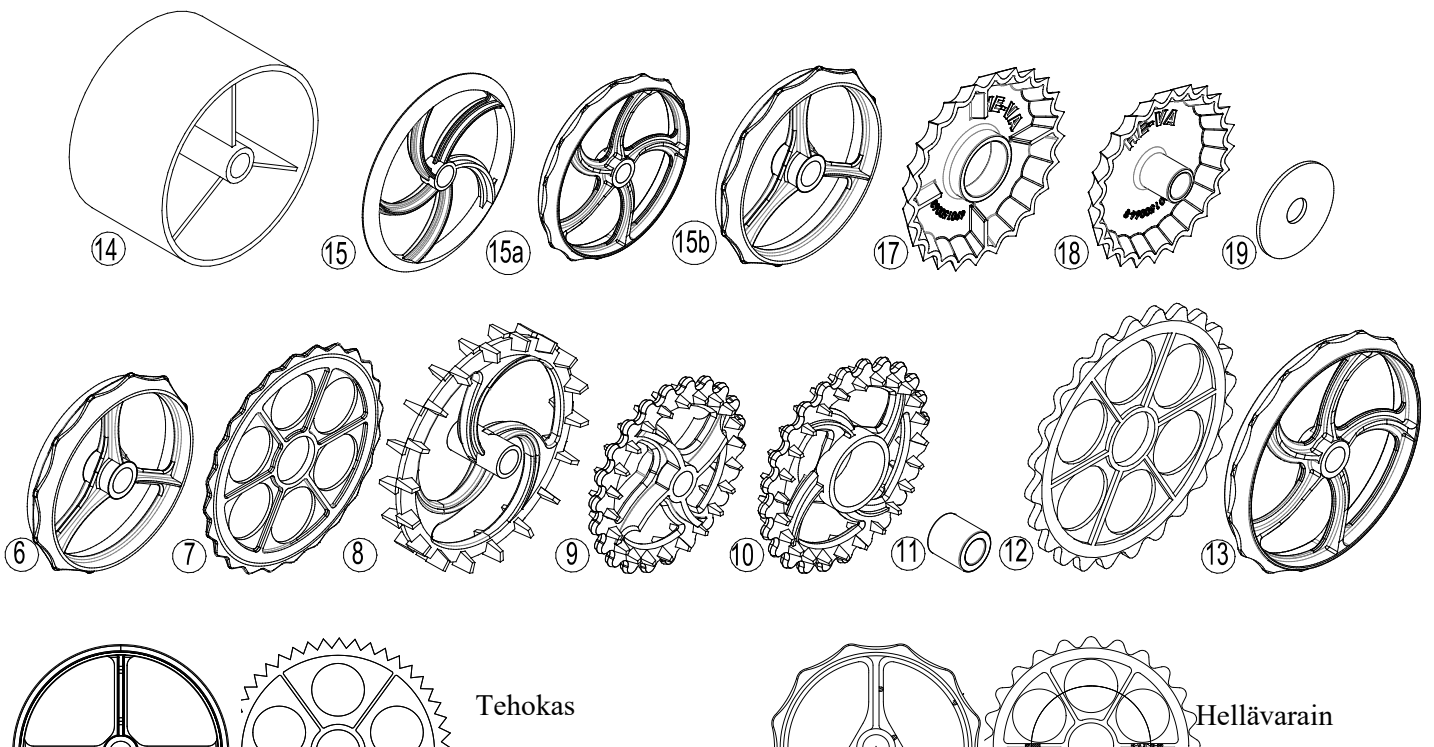
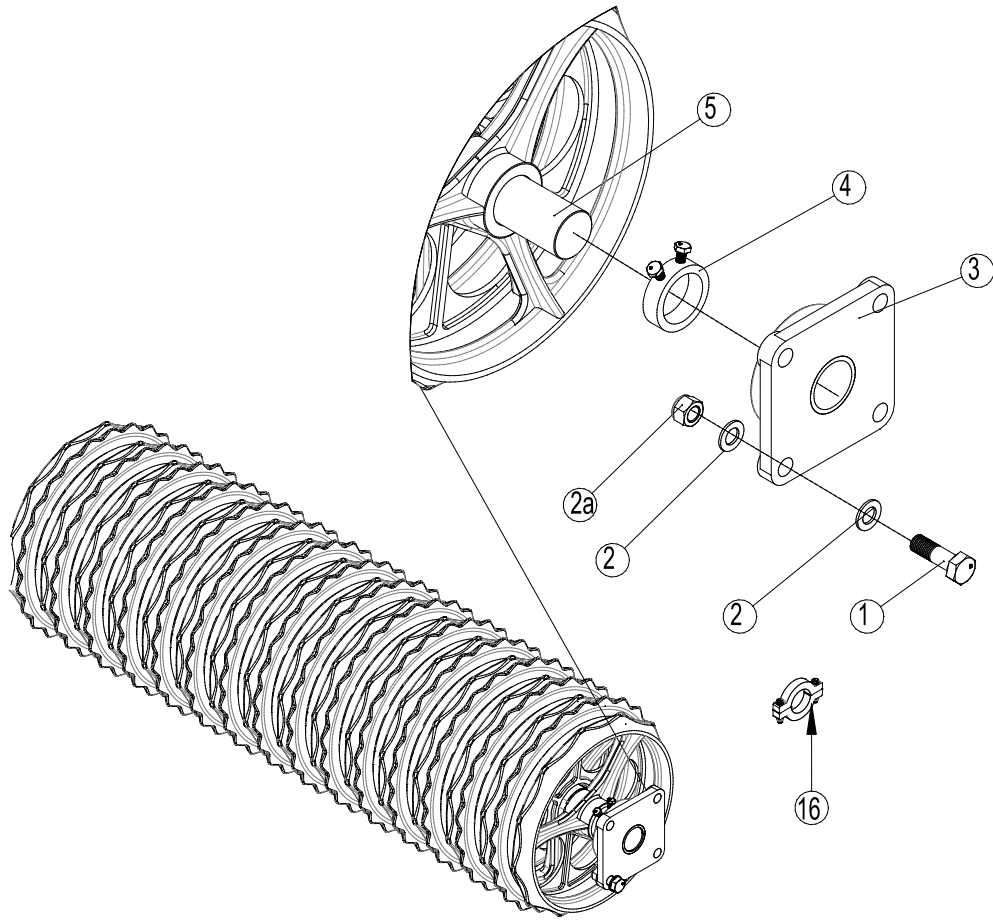

Kohta	Osanro	Nimike	4,5	5,4	6,3
1	0235830	Pultti M16x55	24	24	24
2	0272290	Aluslevy Ø16	48	48	48
2a	0264090	Lukkomutteri M16	24	24	24
3	690140812	Laakeri UCF 309, ø45, 4-reik., ø50 akseli	6	6	6
3	690140813	Laakeri UCF 211, ø55, 4-reik., ø60 akseli	6	6	6
4	630552300	Lukitusrengas pultilla, ø50 akseli	3	3	3
4	671040400	Lukitusrengas pultilla, ø60 akseli	3	3	3
4a	691040045	Laakerin UCF 309 lukituspultti, M10x1.25 P=12	6	6	6
4a	691040046	Laakerin UCF 211 lukituspultti, M10x1.0 P=10	6	6	6
5	678541736	Keskilohkon+sivulohkon akseli Ø50 st70 P=1736	3	0	0
5	678542066	Keskilohkon+sivulohkon akseli Ø50 st70 P=2066	0	3	0
5	678542370	Keskilohkon+sivulohkon akseli Ø50 CrNi P=2370	0	0	3
5	678661736	Keskilohkon+sivulohkon akseli Ø60 teräs70 P=1736	3	0	0
5	678662063	Keskilohkon+sivulohkon akseli Ø60 teräs70 P=2063	0	3	0
5	678662370	Keskilohkon+sivulohkon akseli Ø60 teräs70 P=2370	0	0	2
5	678692370	Keskilohkon+sivulohkon akseli Ø60 CrNiMo6 L=2370	0	0	1
6	690150039	Cambridge sileä kiekko 18" (Ø60) hellävarainen	45	54	63
7	690150040	Cambridge harjakiekko 18" (Ø60) hellävarainen	42	51	60
6	690150024	Cambridge sileä kiekko 21" (Ø60) tehokas	45	54	63
6	690150030	Cambridge sileä kiekko 21" (Ø60) hellävarainen	45	54	63
7	690150025	Cambridge harjakiekko 21" (Ø60) tehokas	42	51	60
7	690150032	Cambridge harjakiekko 21" (Ø60) hellävarainen	42	51	60
8	690150007	Jyräpyörä 22" (Ø50)	30	36	42
9	690150034	Cross-kill rengas ø485 mm (Ø60)	24	27	33
9	690150074	Cross-kill rengas ø550 mm (Ø60)	24	27	
10	690150011	Erill. cross-kill rengas ø530 mm	21	27	30
10	690150075	Erill. cross-kill rengas ø600 mm	21	27	
11	690150076	Erill. cross-kill renkaan napa Ø60	21	27	30
12	690150059	Harjakiekko Ø620/Ø60 24" alkaen koneen nrosta 342089	42	51	0
13	690150049	Sileä kiekko Ø620/Ø60 24" alkaen koneen nrosta 342089	45	54	0
12	690150102	Harjakiekko Ø560	42	51	
13	690150101	Sileä kiekko Ø560	45	54	
14	690150028	Sileä kiekko Ø505 (ø60)	15	18	21
15	690150013	Aaltokiekko Ø500 (ø60) lopettaa 1. huhtikuuta 2011	90	108	126
15a	690150050	2D aaltokiekko 600mm alk. 1. huhtikuuta 2011			
15a	690150109	2D aaltokiekko 550 mm	57	69	
15b	690150087	2D aaltokiekko 500 mm alk. 1. huhtikuuta 2011	57	69	78
16	690150091	Välirengas 25 mm. Sis. pultti - aluslevyt - mutterit			
16	690150090	Välirengas 15 mm. Sis. pultti - aluslevyt - mutterit			
16	690150099	Välirengas 20 mm. Sis. pultti - aluslevyt - mutterit			

17	690150063	Piikkirengas Ø500, keskusta Ø135	45	54	63
18	690150064	Piikkirengas Ø450 laipalla Ø60	45	54	63
17	690150065	Piikkirengas Ø600, keskusta Ø135	45	54	
18	690150066	Piikkirengas Ø550 laipalla Ø60	45	54	
19	690150112	Piikkirenkaan keskittäjä	3	3	3

Jyrähydrauliikka

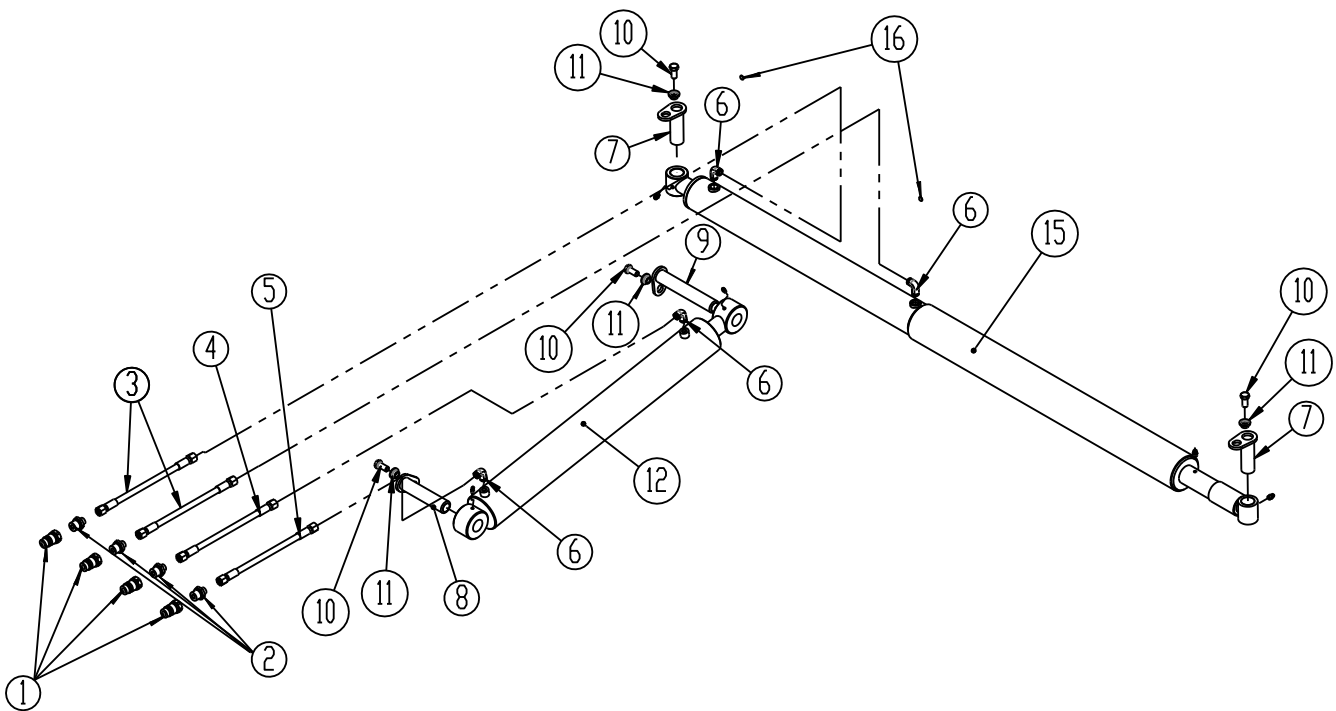

Kohta	Osanro	Nimike	4,5	5,4	6,3
1	690203001	Pikaliitin ½", uros	4	4	4
1a	690119202	Siniset raidat	2	2	2
1b	690119203	Punaiset raidat	2	2	2
2	690203003	Välikappale GA10LK ½"	4	4	4
3	690201004	Hydrauliikkaletku 1/4" P=4950 mm	2	2	0
3	690201034	Hydrauliikkaletku 1/4" P=5500 mm	0	0	2
4	690201006	Hydrauliikkaletku 1/4" P=3800 mm	1	1	0
4	690201029	Hydrauliikkaletku 1/4" P=4300 mm	0	0	1
5	690201005	Hydrauliikkaletku 1/4" P=3300 mm	1	1	0
5	690201007	Hydrauliikkaletku 1/4" P=3700 mm	0	0	1
6	690203006	Kulmaliitin VA10LK 3/8"	4	4	4
7	69430090G	Tappi Ø30 P=90	2	2	2
8	69530135G	Tappi Ø30 P=135	1	1	1
9	69430175G	Tappi Ø30 P=175	1	1	1
10	690101101	Pultti M12x25	4	4	4
11	630532600	Tapin kannan lukkoaluslevy	4	4	4
12	690200050	Nosto- ja laskusylinteri 80/40x500	1	1	0
12	690200350	Nosto- ja laskusylinteri 90/40x500mm v/Ø620mm Cambridge kiekot alkaen koneen nrosta. 342089	-	1	-
12	690200120	Nosto- ja laskusylinteri 80/40x600	0	0	1
12e	690200143	Tiivistesarja 80/40	-	-	-
13	690200010	Lohkosylinteri / painonsiirtosylinteri 60/30x500	1	1	0
13e	690200076	Tiivistesarja 60/30	-	-	-
13	690200030	Lohkosylinteri / painonsiirtosylinteri 70/40x500	0	0	1
13e	690200068	Tiivistesarja 70/40	-	-	-
15	630727010	Painonsiirtosylinteri	1	1	0
15	630757010	Painonsiirtosylinteri	0	0	1
16	690207901	Kuristin (1 mm)	2	2	2

Jousilata

Jousilata vaatii 2-toimisen hydrauliiikan hallintaventtiilin traktorissa. Jousiladan kulma säädetään hydrauliiikan avulla ohjaamosta ja syvyyden säätö on käsikäyttöinen. Jouset toimivat yksilöllisesti mutta ne voidaan liittää yhteen poikittaisella jäykistystangolla (lisävar.) kun tasaustehoa halutaan parantaa. Asennus voidaan tehdä nopeasti ja helposti ilman työkaluja

Jousiladan sylinterien asennus

Hydraulisyylinterit asennetaan alla olevien kuvien mukaan. On tärkeää, että ne asennetaan oikein, jotta sylinterit voidaan kiristää oikeaan momenttiin.

Jyräkiekkotyypin ratkaisee, jos sylinterit on asennettava reikään 1 tai 2. Jos koneessa on 450 tai 550 mm jyräkiekot, on sylinterit asennettava reikään 1 tai reikiin 1a tai 1b. Jos koneessa on 620 mm jyräkiekot, on sylinterit asennettava reikään 2 tai reikiin 2a tai 2b.

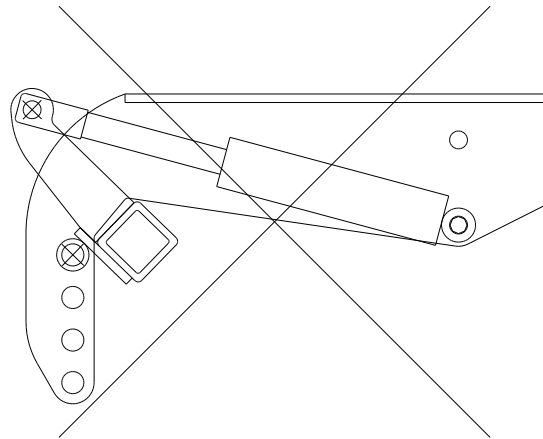
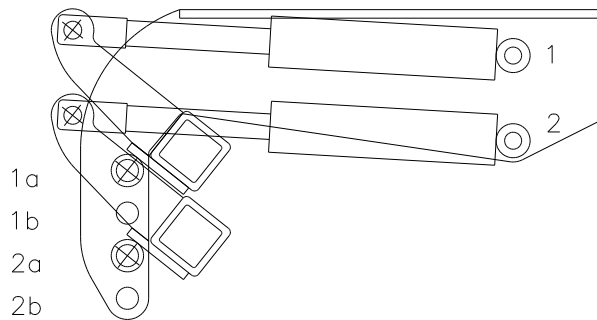

Jousiladan keskilohko

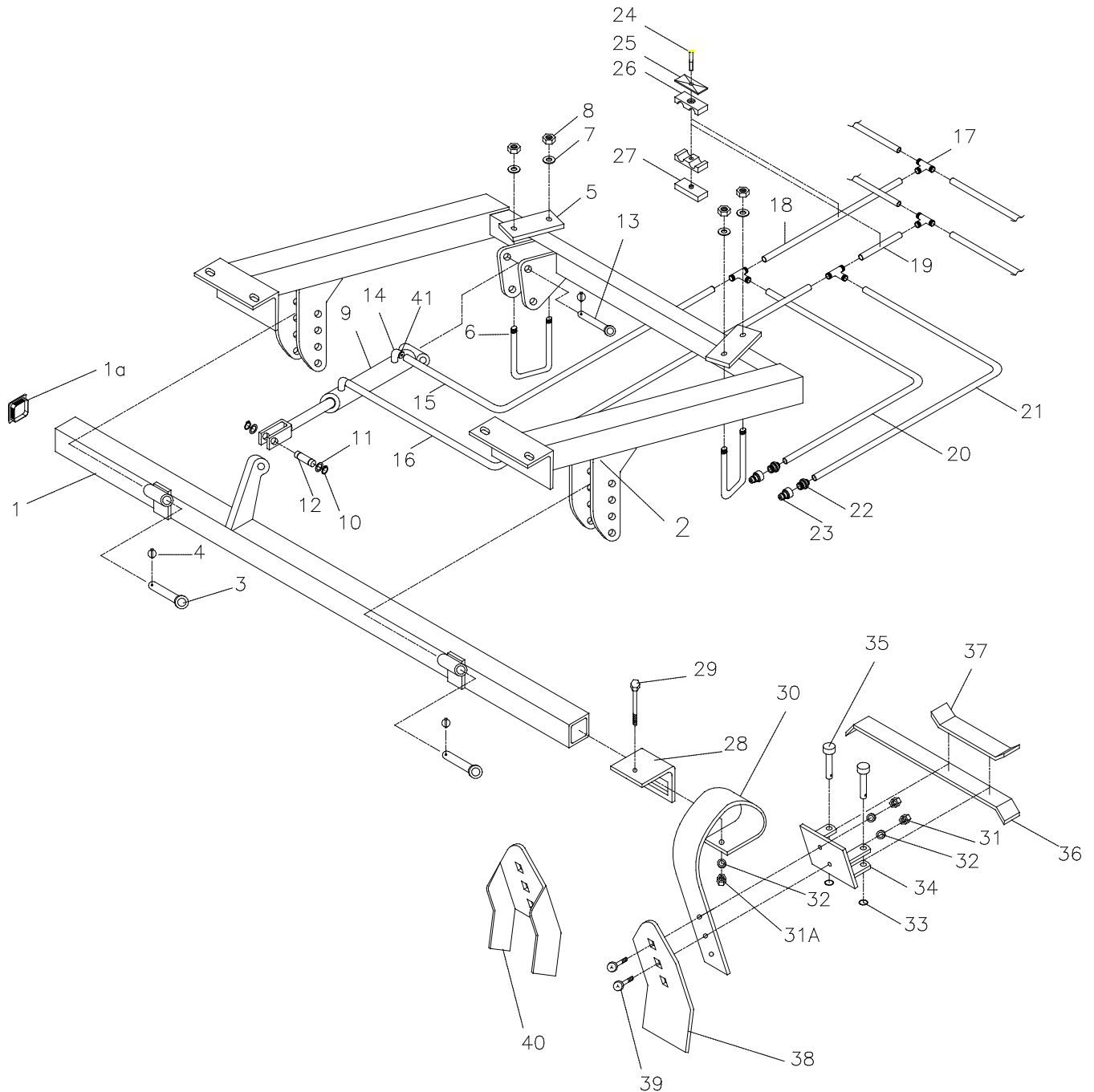

Kohta	Osanro	Nimike	4,5 m	5,4 m	6,3 m
1	633033020	Jousipalkki	1	0	0
1	633043020	Jousipalkki	0	1	0
1	633053020	Jousipalkki	0	0	1
1A	690109202	Profiliputken muovitulppa 70x70x3,6	2	2	2
2	633031000	Keskilohkon kiinnike	1	0	0
2	635041000	Keskilohkon kiinnike	0	1	0
2	635041001	Keskilohkon kiinnike alk. koneen nrosta 342089		1	
2	633051000	Keskilohkon kiinnike	0	0	1
3	69525087F	Tappi Ø25 P=87	2	2	2
4	0378200	Sokka Ø4,5	3	3	3
5	670861100	Laippa	2	2	2
6	690110101	Kiinnitysside M16x100x100x100	2	2	2
7	0272900	Levy Ø16	4	4	4
8	0264090	Mutteri M16	4	4	4
9	690200160	Sylinteri 50/30x155	1	1	1
9e	690200045	Tiivistesarja 50/30 mm	-	-	-
10	691372020	Lukkorengas U 20 A2 Din 471	2	2	2
11	690115010	Lukituslevy Ø20/Ø28x1mm	2	2	2
12	69520046D	Tappi Ø20 P=46	1	1	1
13	69520087F	Tappi Ø20 P=87	1	1	1
14	690203006	Kulmaliitos VA10LK 3/8"	2	2	2
15	690201015	Hydrauliikkaletku 1/4" P=710 mm	1	0	0
15	690201051	Hydrauliikkaletku 1/4" P=250 mm	0	1	1
16	690201015	Hydrauliikkaletku 1/4" P=710 mm	1	0	0
16	690201059	Hydrauliikkaletku 1/4" P=350 mm	0	1	1
17	690203015	T-kappale T10	4	4	4
18	690201040	Hydrauliikkaletku 1/4" P=1480 mm	1	0	0
18	690201032	Hydrauliikkaletku 1/4" P=1130 mm	0	1	0

Kohta	Osanro	Nimike	4,5 m	5,4 m	6,3 m
18	690201032	Hydrauliikkaletku 1/4" P=1160 mm	0	0	1
19	690201040	Hydrauliikkaletku 1/4" P=1480 mm	1	0	0
19	690201053	Hydrauliikkaletku 1/4" P=1260 mm	0	1	0
19	690201053	Hydrauliikkaletku 1/4" P=1260 mm	0	0	1
20	690201060	Hydrauliikkaletku 1/4" P=3000 mm	1	0	0
20	690201044	Hydrauliikkaletku 1/4" P=3460 mm	0	1	0
20	690201038	Hydrauliikkaletku 1/4" P=4000 mm	0	0	1
21	690201060	Hydrauliikkaletku 1/4" P=3000 mm	1	0	0
21	690201005	Hydrauliikkaletku 1/4" P=3300 mm	0	1	0
21	690201006	Hydrauliikkaletku 1/4" P=3800 mm	0	0	1
22	690203003	½" välikappale (uros)	2	2	2
23	690203001	Pikaliitin (uros) ½"	2	2	2
24	690210213	Letkupidikkeen (ø14, ø15, ø16, ø18) ruuvi	5	5	5
25	690210211	Letkupidikkeen (ø14, ø15, ø16, ø18) päällyslevy	5	5	5
26	690210210	Letkupidike ø14/ø14	10	10	10
27	690210212	Letkupidikkeen (ø14, ø15, ø16, ø18) aluslevy	5	5	5
28	0422390	Jousen kiinnike	6	8	8
29	690103098	Pultti M12x110	6	8	8
30	0422145	Jousi (10x80)	6	8	8
30a	633052000	Jousi täyd., tasakärkinen	6	8	8
31	0264070	Lukkomutteri M12	18	24	24
32	0272270	Aluslevy ø12	18	24	24
33	0431975	Lukkorengas 30xø3	12	16	16
34	633055500	Jäykistystangon kiinnike	6	8	8
35	69512040K	Tappi Ø12,5 x 40	12	16	16
36	633055710	Jäykistystanko, pitkä	10	14	14
37	633055700	Jäykistystanko, lyhyt	2	2	2
38	633052100	Kärki (8x150)	6	8	8
39	0248670	Pultti M12 x 45	12	16	16
40	633052150	Kärki (kuoretuksen rikkoja)	6	8	8
41	690207901	Kuristin (1 mm)	1	1	1

Jousilata – Vasen lohko

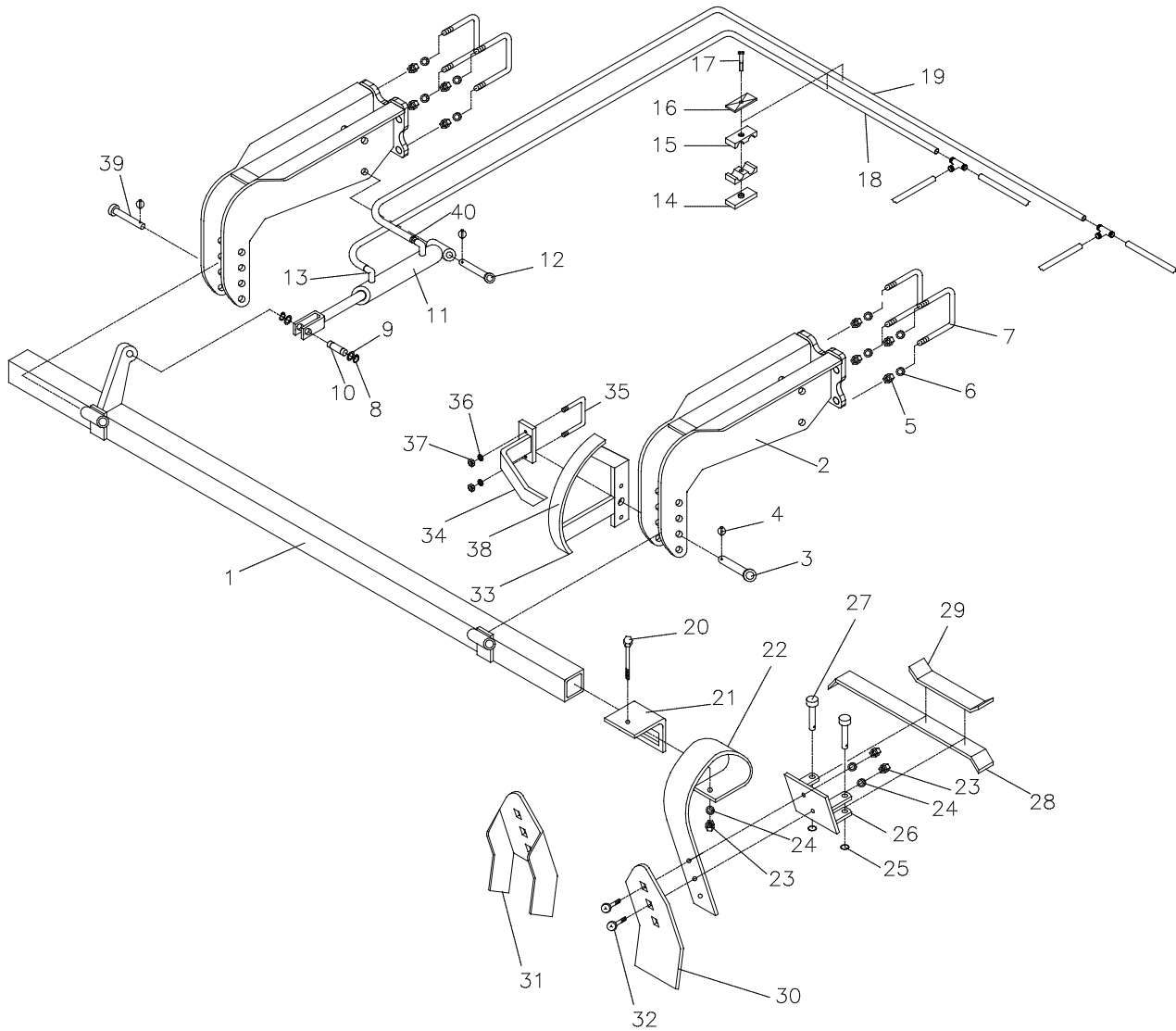

Kohta	Osanro	Nimike	4,5 m	5,4m	6,3m
1	633033010	Jousipalkki (oikea)	1	0	0
1	633033030	Jousipalkki (vasen)	1	0	0
1	633043010	Jousipalkki (oikea)	0	1	0
1	633043030	Jousipalkki (vasen)	0	1	0
1	635053010	Jousipalkki (oikea)	0	0	1
1	635053030	Jousipalkki (vasen)	0	0	1
2	633054500	Jousipalkin kiinnike	4	4	4
2	633054520	Jousipalkin kiinnike alk. 1. kesäkuuta 2010	4	4	4
3	69525095F	Tappi Ø25 P=95	1	1	1
4	690134001	Sokka Ø4,5	6	6	6
5	690113008	Lukkomutteri M16	16	16	16
5	690113016	Lukkomutteri M18 alk. 1. kesäkuuta 2010	16	16	16
6	0272900	Levy Ø16	16	16	16
6	690117015	Levy Ø18 alk. 1. kesäkuuta 2010	16	16	16
7	690110402	Kiinnitysside M16x160x80x160 mm	8	8	8
7	690110405	Kiinnitysside M18x160x80x160 mm alk. 1. kesäkuuta 2010	8	8	8
8	691372020	Lukkorengas U 20 A2 Din 471	4	4	4
9	690115010	Lukituslevy Ø20/Ø28x1mm	4	4	4
10	69520046D	Tappi Ø20 P=46	2	2	2
11	690200160	Sylinteri 50/30 x 155	2	2	2
11e	690200045	Tiivistesarja 50/30 mm	2	2	2
12	69520087F	Tappi Ø20 P=87	2	2	2
13	690203006	Kulmaliitos VA10LK 3/8"	4	4	4
14	690210212	Letkupidikkeen (ø14, ø15, ø16, ø18) aluslevy	6	6	8
15	690210210	Letkupidike ø14/ø14	12	12	16
16	690210211	Letkupidikkeen (ø14, ø15, ø16, ø18) päällyslevy	6	6	8
17	690210213	Ruuvi M8x40	6	6	6
18	690201022	Hydrauliikkaletku 1/4" vasen sivulohko P=3140 mm	1	0	0
18	690201005	Hydrauliikkaletku 1/4" oikea sivulohko P=3300 mm	1	0	0
18	690201044	Hydrauliikkaletku 1/4" vasen sivulohko P=3460 mm	0	1	0
18	690201048	Hydrauliikkaletku 1/4" oikea sivulohko P=3610 mm	0	1	0

18	690201048	Hydrauliikkaletku 1/4" vasen sivulohko P=3610mm	0	0	1
18	690201006	Hydrauliikkaletku 1/4" oikea sivulohko P=3800 mm	0	0	1
19	690201060	Hydrauliikkaletku 1/4" vasen sivulohko P=3000 m	1	0	0
19	690201060	Hydrauliikkaletku 1/4" oikea sivulohko P=3000 mm	1	0	0
19	690201022	Hydrauliikkaletku 1/4" vasen sivulohko P=3140mm	0	1	0
19	690201005	Hydrauliikkaletku 1/4" oikea sivulohko P=3300 mm	0	1	0
19	690201044	Hydrauliikkaletku 1/4" vasen sivulohko P=3460mm	0	0	1
19	690201048	Hydrauliikkaletku 1/4" oikea sivulohko P=3610 mm	0	0	1
20	690103098	Pultti M12x110	12	14	16
21	0422390	Jousen kiinnike	12	14	16
22	0422145	Jousi (10x80)	12	14	16
22a	633052000	Jousi täyd.	12	14	16
23	0264070	Lukkomutteri M12	36	42	48
24	0272270	Aluslevy ø12	36	42	48
25	0431975	Lukkorengas 30xø3	24	28	32
26	633055500	Jäykistystangon kiinnike	12	14	16
27	69512040K	Tappi ø12.5x40	24	28	32
28	633055710	Jäykistystanko, pitkä	10	12	14
29	633055700	Jäykistystanko, lyhyt	4	4	4
30	633052100	Kärki (8x150)	12	14	16
31	633052150	Kärki (kuoretuksen rikkoja)	12	14	16
32	0248670	Pultti M12x45	24	28	32
33	635151000	Syvyyssäädön asteikko	1	1	1
34	635152000	Syvyyssäädön osoitin	1	1	1
35	690110020	Kiinnitysside M10x70x70x70 mm	1	1	1
36	0272260	Aluslevy ø10	2	2	2
37	0264060	Lukkomutteri M10	2	2	2
38	698500018	Jousiladan asteikkotarra	1	1	1
39	69525087F	Tappi Ø25 P=87	3	3	3
40	690207901	Kuristin (1mm)	2	2	2

Valot

LED Valosarja

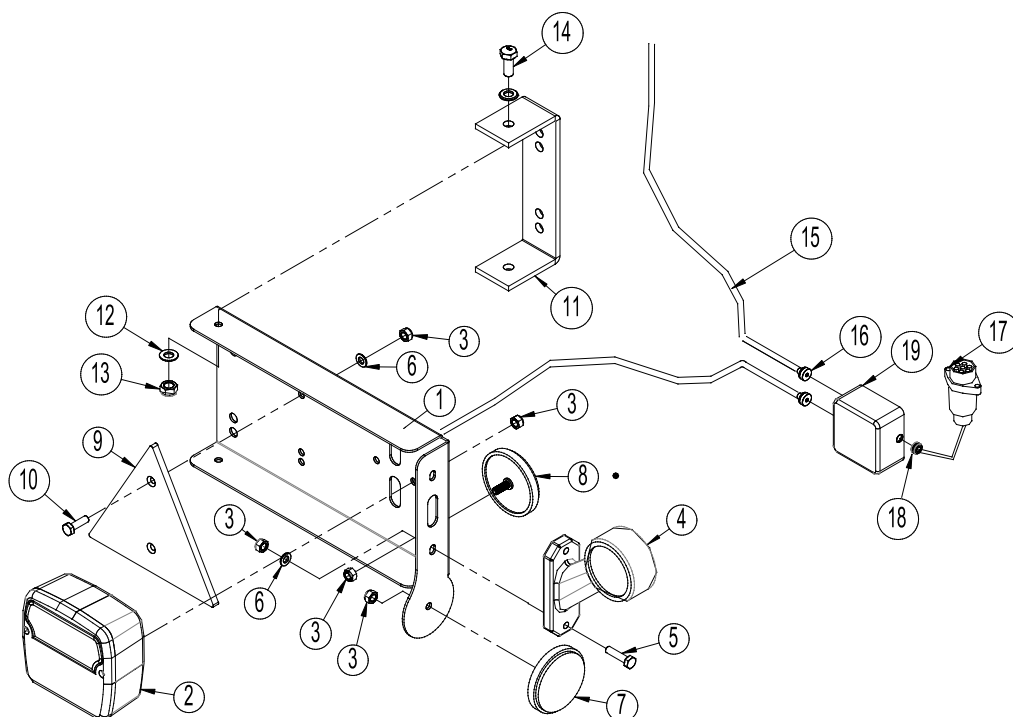

Kohta	Osanro	Nimike	Lukumäärä
1	7357505	Lightbox (L)	1
	7357508	Lightbox (R)	1
2	7357504	Rear light	2
3	0264030	Locking nut M5	16
4	7357507	Marking lights (L)	1
	7357509	Marking lights (R)	1
5	0234340	Bolt M5x25	4
6	0272240	Facet plate Ø5	8
7	0656240	Reflex, yellow	2
8	0656250	Reflex, white	2
9	690160017	Reflex, red	2
10	0234330	Bolt M6x20	4
11	7357516	Bracket	2
12	0272250	Facetplate Ø8	16
13	0264050	Locking nut M8	8
14	0234750	Bolt M8x20	4
15	690160080	Cable 5 x 1mm ² (Inform about length by ordering sparepart)	
16	7357545	Rutaseal nipple M20 8-12mm Grey RAL7001	2
17	690160070	Plug 7 poles DIN 72 577 – ISO 1724	1
18	7357546	Rubberbushing Nr. 38A Ø10/3 black	1
19	0520492	Junction box 105x105x60	1

Huomioi:

Kaapelien määrä ja pituus voi vaihdella konemallin mukaan. Tarkista mitat ja lukumäärä ennen varaosien tilaamista.

Valosarja: Sähkökaavio

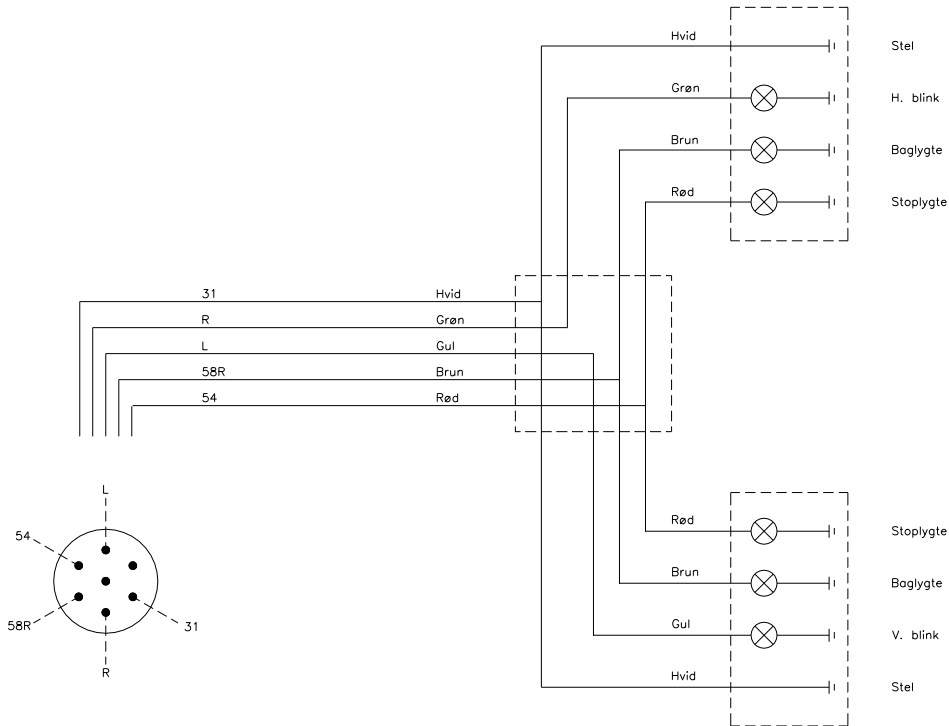

Easy Change System

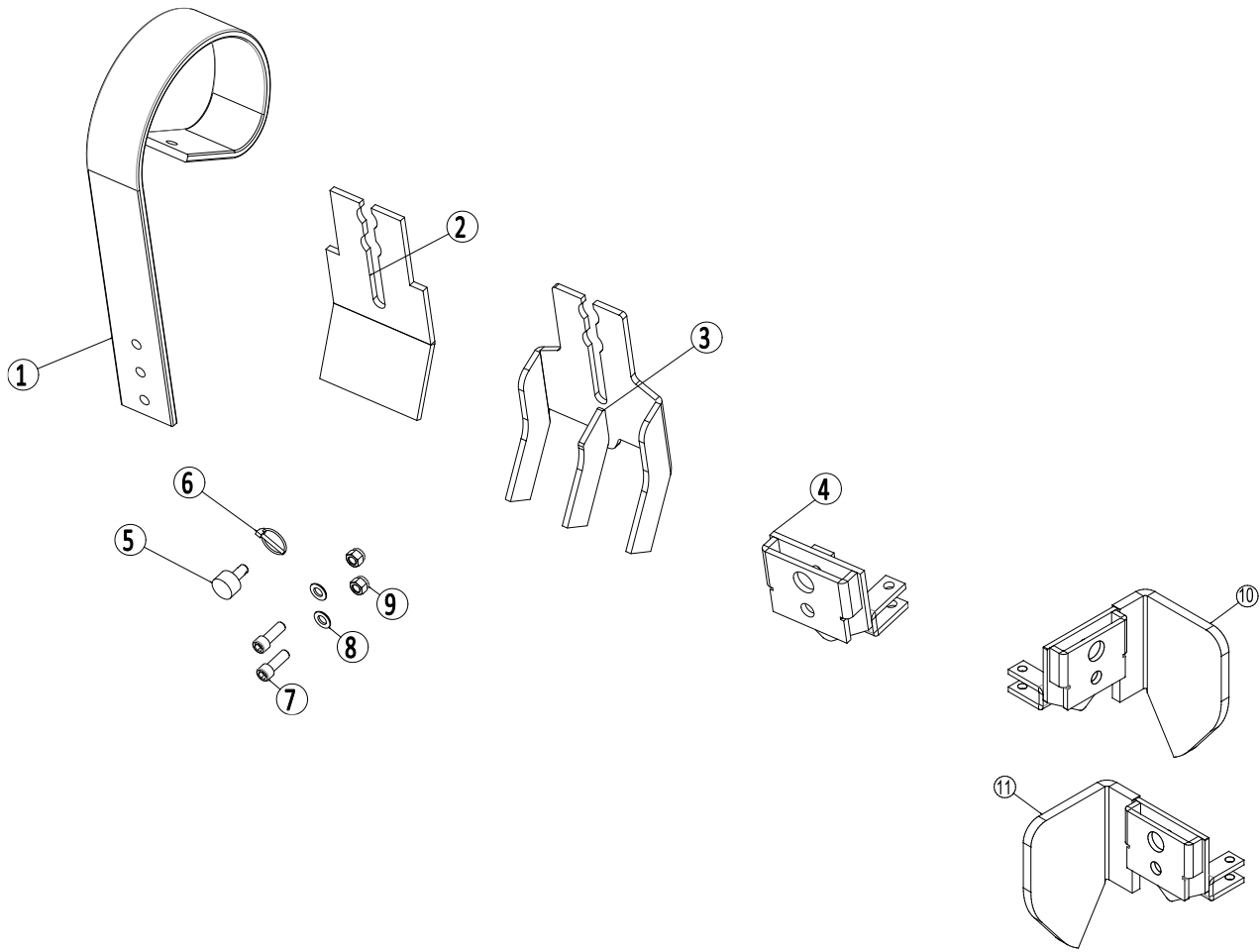

Kohta	Tuotenumero	Nimike	Lukumäärä
1	0422145	Jousiladan piikki	1
2	1170388	Tasainen kärki - Easy-Change	1
3	1170410	3 - kuorettumisen rikkova kärki – Easy-Change	1
4	1170389	Easy-Change jäykistystangon kiinnike	1
5	1170391	Lukkotappi	1
6	0378200	Rengassokka Ø4,5 mm	1
7	0227842	Pultti M12 x 35 8.8	2
8	0272270	Aluslevy	2
9	0264070	Lukkomutteri M12	2
10	1170806	Edge equipment, left	1
11	1170805	Edge equipment, right	1

Maskiner til vækst

Maskiner til vækst

Maskiner til vækst

Maskiner til vækst

Maskiner til vækst

Maskiner til vækst



Pidätämme oikeudet muutoksiin siitä erikseen ilmoittamatta.