

# FRONT-BOARD

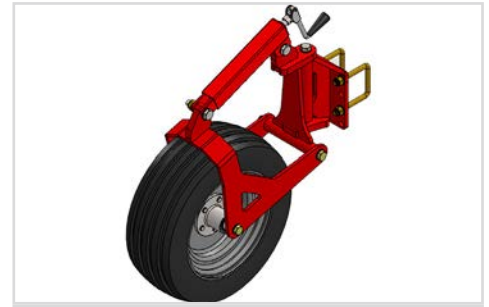

4.00 m Front-Board with slicing plates.



Wheels: 200/60x14.5 on all models.

- Depth wheel placed according to preparation - to ensure a precise preparation.
- Spindle adjustment of working depth.
- Hydraulic adjustment of working angle.
- Compact machine.
- Three-point linkage with cat. 2 pins and cat. 2 distance.

## MACHINES

Work Width, m	Type	Description	Weight, kg	Item Number
3.00	Rigid	Front-Board with 21 tines, hydraulic adjustment of tine rows	1 <sup>*</sup> 520	67501-00
4.00	Rigid	Front-Board with 29 tines, hydraulic adjustment of tine rows	1 <sup>1/3</sup> * 630	67502-00
4.00	Foldable	Front-Board with 29 tines, hydraulic adjustment of tine rows	2 <sup>*</sup> 880	67502-50
5.00	Foldable	Front-Board with 40 tines, hydraulic adjustment of tine rows	2 <sup>*</sup> 1,050	67503-00
6.00	Foldable	Front-Board with 44 tines, hydraulic adjustment of tine rows	2 <sup>*</sup> 1,220	67504-00

<sup>1</sup>Requires 1 double-acting oil outlet.

<sup>2</sup>Requires 2 double-acting oil outlets.

<sup>3</sup>Can manually be changed to 3.00 m transport width

## STANDARD EQUIPMENT

- Wheels, 2 pcs.: 200/60x14.5 on all models.
- Two hydraulically adjustable tine rows with Spring-Board tines, with 150 mm wide tine point.
- The mutual angle between the tine rows is mechanically adjustable.
- Support stand, pins and locking pins.

## EXTRA EQUIPMENT

Description	Weight, kg	Item Number
LED marking lights with clear and red glass	4	63098-02
Set of reflective warning boards (2 pieces)	8	67055-74
Weight console, for bolting on of additional weight (front weight needs to be specified)	32	67086-00
Edge equipment set for Spring-Board tines	11	63301-00
Deduction f/supply w/spindle adjustment of working angle	-	-

Work Width, m	Description	Weight, kg	Item Number
<b>TRANSVERSE LOCKING SYSTEM - CONNECTS THE SPRING-BOARD TINES</b>			
3.00	Complete kit (Price per tine row)	35	67601-00
4.00	Complete kit (Price per tine row)	47	67602-00
5.00	Complete kit (Price per tine row)	55	67603-00
6.00	Complete kit (Price per tine row)	71	67604-00

SLICING PLATES ADDITIONAL PRICE IF SLICING PLATES ARE REQUIRED INSTEAD OF 150 MM WIDE TINE POINT				
Work Width, m	Description	No. of Tines Front	No. of Tines Rear	Item Number
3.00	Additional price per tine row	10	11	67621-00
4.00	Additional price per tine row	14	15	67622-00
5.00	Additional price per tine row	18	18	67623-00
6.00	Additional price per tine row	22	22	67624-00



"EASY-CHANGE" QUICK CHANGE SYSTEM OF WEAR POINTS INCL. ONE SET OF FLAT WEAR POINTS AND ONE SET OF SLICING PLATE POINTS WITH 3 TINES.	
Description	Item Number
Additional price per tine in relation to standard Spring-Board	63302-00
Price per tine for retrofitting	63302-01