

# TOP-CUTTER SOLO



- Standard front mounted machine with the option of rear mounting with a double three-point linkage (see extra equipment).
- The six blades ensure a smooth and stable workflow.
- HE-VA's unique closed tube design prevents soil and residues from building up and sticking to the construction.
- Available with both a single knife roller (SINGLE) and with two knife rollers (TWIN). Roller diameter incl. knives: Ø390 mm.
- The TWIN-models' knife rollers are placed with opposite cutting directions and therefore cuts crops in 2 different directions to achieve better shredding and faster decomposition.
- Three-point linkage with cat. 2 pins and cat. 2 distance.

## MACHINES

Work Width, m	Type	Description	Weight, kg	Item Number
3.00	Rigid	Single - single knife roller	678	67055-05
3.00	Rigid	Twin - double knife roller	990	67055-10
3.50	Rigid	Single - single knife roller	780	67055-15
3.50	Rigid	Twin - double knife roller	1,043	67055-20
4.00	Rigid	Single - single knife roller	890	67055-25
4.00	Rigid	Twin - double knife roller	1,180	67055-30
4.00	Foldable	Single - single knife roller	1,250	67055-40
4.00	Foldable	Twin - double knife roller	1,620	67055-45
5.00	Foldable	Single - single knife roller	1,360	67055-50
5.00	Foldable	Twin - double knife roller	1,810	67055-55
6.00	Foldable	Single - single knife roller	1,650	67055-60
6.00	Foldable	Twin - double knife roller	2,050	67055-65



## EXTRA EQUIPMENT

Work Width, m	Type	Description	Item Number
3.00 - 4.00	Rigid	LED marking lights for front mounting with clear and red glass	67055-72
3.00 - 4.00	Rigid	LED lights for rear mounting	67055-73
3.00 - 4.00	Rigid	Set of reflective warning boards (2 pieces)	67055-74
4.00 - 6.00	Foldable	LED marking lights for front mounting with clear and red glass	67055-78
4.00 - 6.00	Foldable	LED lights for rear mounting	67055-79
4.00 - 6.00	Foldable	Set of reflective warning boards (2 pieces)	67055-86
3.00 - 4.00	Rigid	Three-point linkage for front- and rear mounting	67055-70
4.00 - 6.00	Foldable	Three-point linkage for front- and rear mounting	67055-71
3.00 - 6.00	-	Extra weights of 30 kg, max. 60 kg./m	67055-75
3.00	Rigid	Material damper guard	67055-80
3.50	Rigid	Material damper guard	67055-81
4.00	Rigid	Material damper guard	67055-82
4.00	Foldable	Material damper guard	67055-83
5.00	Foldable	Material damper guard	67055-84
6.00	Foldable	Material damper guard	67055-85

### CUTTER-BOARD - SPRING MOUNTED LEVELLING BAR, MECHANICALLY HEIGHT ADJUSTABLE MOUNTED IN FRONT OF TOP-CUTTER SOLO FOR MAIZE- AND RAPE STUBBLE

Work Width, m	Type	Description	Item Number
3.00	Rigid	Cutter-Board	67055-90
3.50	Rigid	Cutter-Board	67055-91
4.00	Rigid	Cutter-Board	67055-92
4.00	Foldable	Cutter-Board	67055-93
5.00	Foldable	Cutter-Board	67055-94
6.00	Foldable	Cutter-Board	67055-95



Extra weights of 30 kg. Max. 60 kg./m.



Material damper guard.



Three-point linkage on Top-Cutter Solo, enabling both front- and rear mounting.

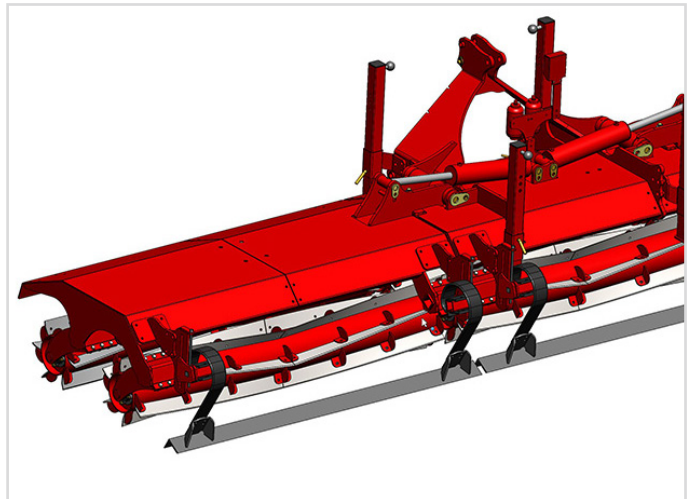

Cutter-Board - spring mounted levelling bar.