



**Operating Instructions
Declaration of conformity**

Information's of HE-VA Front-PTO

Specific manual for each tractor model by
contacting HE-VA

Gear type HI, HN, HQ

HE-VA Front-PTO

Preface

After installation of the HE-VA Front PTO System your tractor will be equipped with a unit, which combined with a Front-Lift will considerably increase the possible applications of the tractor. Both as a tool carrier in the modern farming and for use for the maintenance of roads and parks the system will contribute to minimising the necessary number of driving hours.

Before you start using your new PTO System, you should read this Instruction Manual carefully, primarily because of the safety in the use, but also to avoid any damages to the PTO System and the tractor.

Especially you have to check the System during the first hours of operation, i.e. loose bolts and any oil or cooling liquid leak. Later on the PTO System may follow the service check-ups of the tractor. In principle the HE-VA PTO System consists of a cardan shaft, gearbox, necessary suspension fittings as well as wiring. The gearbox reduces the number of revolutions in the ration 2.1 : 1.0, i.e. the intentional RPM of 1.000 at the PTO shaft is achieved at motor revolutions of 2.100. The PTO shaft is coupled in with a multiple disk clutch in oil bath activated by means of an integrated hydraulic pump.

The HE-VA PTO Systems are high-quality products, individually adapted to every tractor type. In connection with the installation we have aimed at an optimum design so that the PTO System is a compact and integrated part of the tractor.

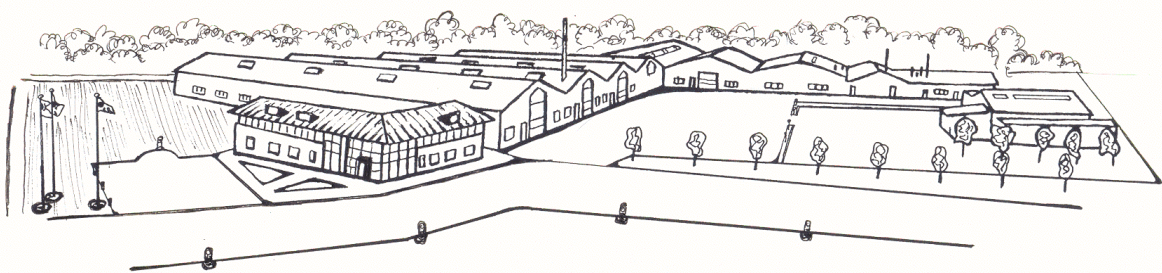

For additional information as regards the installation, please contact:

HE-VA ApS
N.A. Christensensvej 34
DK-7900 Nykøbing Mors
info@he-va.com
Tel. +45 97 72 42 88
Fax +45 97 72 21 12



EC DECLARATION OF CONFORMITY

in accordance with the EU Machinery Directive 2006/42/EC
applicable as from December 29th 2009:

HE-VA ApS
N. A. Christensensvej 34,
DK-7900 Nykøbing Mors

hereby confirms that the following machine has been manufactured in accordance with the Council
Directive 2006/42/EC.

The declaration comprises the following machine:

HE-VA Front-PTO

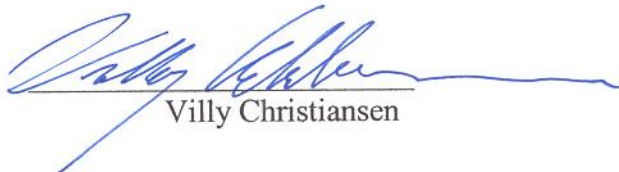

Villy Christiansen

Nykøbing the 29th December 2009

The undersigned is furthermore authorised to compile technical documentation for the above
machine.

HE-VA does not undertake responsibility for any damages to the tractor.

Measures of Precaution

- Stop the motor when a tool is being coupled or uncoupled.
- Before the mounting of a tool, please check that it has been designed for a driving shaft of 1.000 RPM. Tools designed for other RPMs are not applicable.
- Stop the motor during check-up or service at an attached tool.
- Disconnect the Front PTO System when you leave the tractor for a short or a long time, also when the motor is still running.
- When driving on public roads/places, on which other people are present, the Front PTO System shall be disconnected.
- Only use power transmission shafts with proper protection equipment.
- The Front PTO equipment with attached tools may only be used by qualified staff members, familiar with this Instruction Manual.
- When the Front PTO is not used, the protective jacket shall be put on.
- Service and repair work may only be done by qualified staff members.

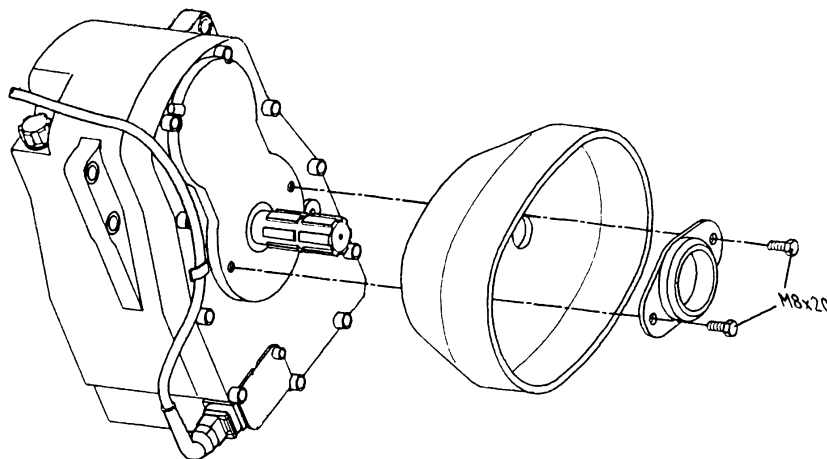

! Warning – Always make sure that the guards are intact!

Operating Instructions

1. Mounting of Front Tools

1.1 Installation of Power Transmission Shaft

Check carefully the length of the power transmission shaft. If the shaft length is too long or too short, the PTO unit will be seriously damaged. The length of the power transmission shaft shall be checked with the Front-Lift in upper as well as in lower position. Furthermore, check that the shaft is running freely in the entire travel area. As a standard the connection pin on the PTO gearbox has 6 keyways and a diameter of 35 mm/13/8". If the length of the power transmission shaft shall be shortened, the shaft manufacturer's instructions shall be observed.

1.2 RPM and Direction of Rotation.

Carefully check when mounting a front tool that it is designed for the same RPM and direction of rotation as the PTO unit. Please note that the HE-VA Front PTO Systems are designed for 1.000 RPM and right turning viewed in the driving direction of the tractor. 1.000 RPM are achieved at motor revolutions of 2.100 RPM.

2. Connection and Disconnection of Front PTO

First start the tractor. At low motor RPMs engage the power switch for PTO connection. Wait for the slow start-up of the PTO System, during which the motor revolutions are increased and the front tool is set in working position.

When disconnecting the front PTO engage the power switch again. Then disconnect the front tool from working position.

3. Safety Measures

In case of blocking or overload of the front tool, never try to restart by repeated connections and disconnections of the PTO System.
Check/clean the front tool carefully before the restart.

Always use power transmission shaft with freewheeling and correctly adjusted overload coupling. Also make sure that the telescope tube of the power transmission shaft is well greased.

Due to the damping effect of the Centaflex clutch the PTO unit must not be used for extremely pulsating loads, like e.g. from stump clearing equipment, stone crushers, liquid manure stirrers, etc.

Connection and disconnection of the PTO unit may in principle only be made with unloaded tools.

Gear type HI

Oil changes shall be made after every 100 hours of operation of the Front PTO System.

Oil type: SUTO SAE 10W-30 (Combined motor/transmissionoil)

- Castrol 10W30 agri mp forttec
- Shell Agrona x oil 10W30
- Hydro Texaco tractor oil 10W30 Suppr universal

Quantity: 1.85 l.

Draining Out

- Remove the drain plug at the gear underside (approx. 1.85 l oil)
- The old oil shall be disposed of in a proper way as per instructions.
- Exchange the copper ring of the drain plug and remount the plug.

Filling

- Remove the oil filling and oil control plug.
- Fill with oil (1.85 l)
- Exchange the copper ring of the oil control plug and remount the plug.
- Clean the oil filling plug and remount it.

Exchange of the Gearbox Oil Filter

The first filter exchange shall be made after 50 hours of operation of the Front PTO System.

Then after every 500 hours of operation of the tractor.

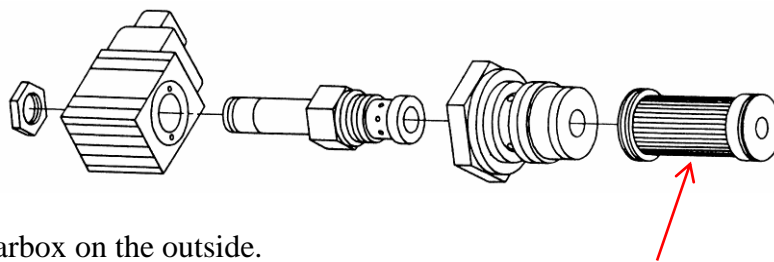

- Clean the gearbox on the outside.
- Remove the guard plate in front of the solenoid valve. Oil-filter: order number 661201107
- Remove the multiple plug from the electric coil of the solenoid valve.
- Remove the narrow nut retaining the electric coil.
- Carefully remove the electric coil from the solenoid valve.
- Then screw the valve out of the union nut.
- Screw the union nut out of the gearbox.
- Pull out the oil filter by screwing an M8 bolt into the thread of the filter.
- Exchange the oil filter.
- Prior to installation of the new oil filter, lubricate all O-rings with grease. Now mount all dismantled parts in the opposite order of the above.



Before gear box serial no. HQ0249

Oil change

The first oil exchange shall be made after 50 hours of operation of the Front PTO System. Then after every 500 hours of operation of the tractor.

Oil type: STOU SAE 10W40

Example:

- Statoil Multigrade PS 10W40
- Q8 T5000
- Shell Harvella TX 10W40
- Or any other brands with same specifications

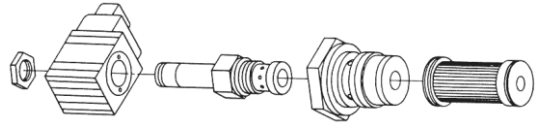

Other oil brands may cause gear defects. We cannot give warranty in any case of disregard of this instruction.

Quantity: 2.7 l.

Draining Out

- Remove the drain plug (M30x1,5) at the gear underside.
- The old oil shall be disposed of in a proper way as per instructions.
- Exchange the copper ring of the drain plug and remount the plug.



Filling

- Fill the gear with oil up to the upper edge of the oil-level gauge, make a test run, top up lacking quantity in oil-level gauge if necessary and add maximum of 0.4 l of oil.

Oil filter, order nr. 661201107

Exchange of the Gearbox Oil Filter

The first filter exchange shall be made after 50 hours of operation of the Front PTO System. Then after every 500 hours of operation of the tractor.

Clean the gearbox on the outside.

- Remove the guard plate in front of the solenoid valve.
- Remove the multiple plug from the electric coil of the solenoid valve.
- Remove the narrow nut retaining the electric coil.
- Carefully remove the electric coil from the solenoid valve.
- Then screw the valve out of the union nut.
- Screw the union nut out of the gearbox.
- Pull out the oil filter by screwing an M8 bolt into the thread of the filter.
- Exchange the oil filter.
- Prior to installation of the new oil filter, lubricate all O-rings with grease.
- Now mount all dismantled parts in the opposite order of the above

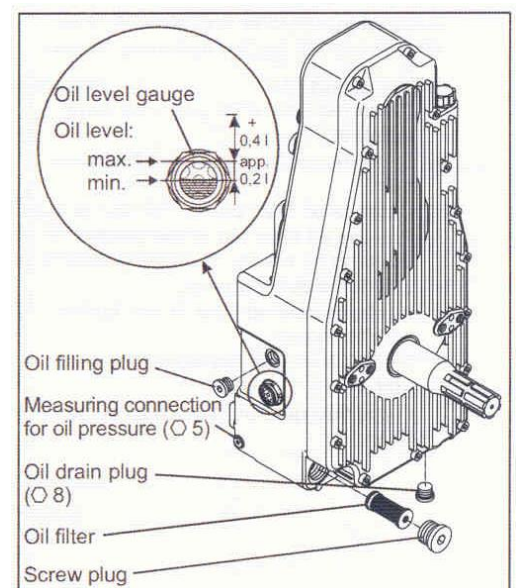

From gear box serial no. HQ0250

Oil change

The first oil exchange shall be made after 50 hours of operation of the Front PTO System. Then after every 500 hours of operation of the tractor.

Olie type: STOU SAE 10W40

example

- Statoil Multigrade PS 10W40
- Q8 T5000
- Shell Harvella TX 10W40
- Or any other brands with same specifications

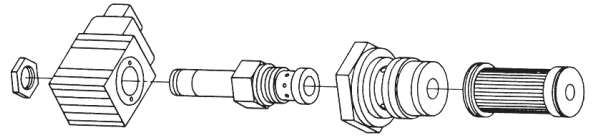

Other oil brands may cause gear defects. We cannot give warranty in any case of disregard of this instruction.

Quantity: 2.7 l.

Draining Out

- Remove the drain plug at the gear underside.
- The old oil shall be disposed of in a proper way as per instructions.
- Exchange the copper ring of the drain plug and remount the plug.



Filling

- Remove the oil filling and oil control plug.
- Fill with oil.
- Exchange the copper ring of the oil control plug and remount the plug.
- Clean the oil filling plug and remount it.

Oil filter, order nr. 661201107

Exchange of the Gearbox Oil Filter

The first filter exchange shall be made after 50 hours of operation of the Front PTO System. Then after every 500 hours of operation of the tractor.

- Clean the gearbox on the outside.
- Remove the guard plate in front of the solenoid valve.
- Remove the multiple plug from the electric coil of the solenoid valve.
- Remove the narrow nut retaining the electric coil.
- Carefully remove the electric coil from the solenoid valve.
- Then screw the valve out of the union nut.
- Screw the union nut out of the gearbox.
- Pull out the oil filter by screwing an M8 bolt into the thread of the filter.
- Exchange the oil filter.
- Prior to installation of the new oil filter, lubricate all O-rings with grease.

Now mount all dismantled parts in the opposite order of the above.

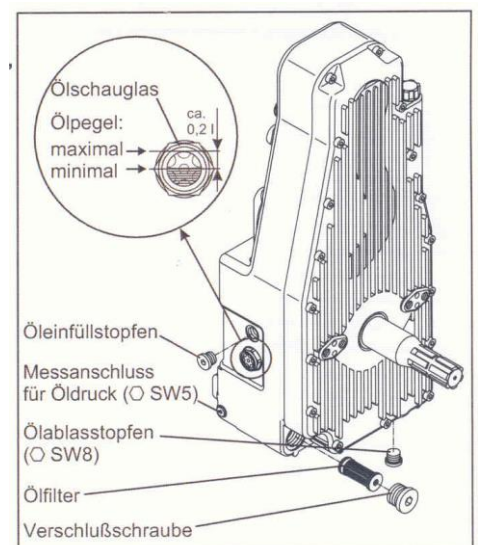

Gear type HN

Oil changes shall be made after every 100 hours of operation of the Front PTO System.

Oil type: SUTO SAE 10W-30 (Combined motor/transmissionoil)

- Castrol 10W30 agri mp fortéc
- Shell Agrona x oil 10W30
- Hydro Texaco tractor oil 10W30 Super universal
- John Deere gear oil Hy-gard

Quantity: 1,85 l.

- **Draining Out**
- Remove the drain plug at the gear underside (approx. 1.85 l oil)
- The old oil shall be disposed of in a proper way as per instructions.
- Exchange the copper ring of the drain plug and remount the plug.
- **Filling**
- Remove the oil filling and oil control plug.
- Fill with oil (1.85 l)
- Exchange the copper ring of the oil control plug and remount the plug.
- Clean the oil filling plug and remount it.

Exchange of the Gearbox Oil Filter

The first filter exchange shall be made after 50 hours of operation of the Front PTO System.

Then after every 500 hours of operation of the tractor, or once a year

- Clean the gearbox on the outside
- Remove the guard plate in front of the solenoid valve. Oil-filter: order number 661201171
- Remove the multiple plug from the electric coil of the solenoid valve.
- Remove the narrow nut retaining the electric coil.
- Carefully remove the electric coil from the solenoid valve.
- Then screw the valve out of the union nut.
- Screw the union nut out of the gearbox.
- Pull out the oil filter by screwing an M8 bolt into the thread of the filter.
- Exchange the oil filter.
- Prior to installation of the new oil filter, lubricate all O-rings with grease
- Now mount all dismantled parts in the opposite order of the above.

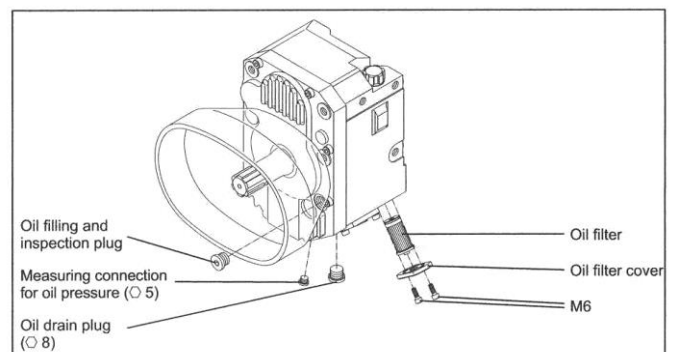

Equipment Specification/Agent/Owner Information

If the guarantee shall apply, the following items shall be filled in:

Equipment No.: _____

Equipment type: _____

Installed on tractor type: _____

Date of installation: _____ / ____ / _____

Name, address, tel. No., possible stamp of the dealer:

Has the equipment been installed by the dealer: Yes No

Otherwise state the name, address, tel. No. and possible stamp of the installation company:

The equipment has been tested and approved: _____ / ____ / _____

Name, address, tel. No. and possible stamp of the Owner:

Guarantee Conditions

The components delivered are guaranteed for 1 year, furthermore, we refer to the valid general guarantee conditions for agricultural machinery.

In case of exchange and sale of the tractor, remember to deliver the operating instructions.

The guarantee period applies from the date, on which the equipment was delivered to the customer.

It is a condition for the guarantee coverage that the installation has been carried out by a skilled staff at an acknowledged workshop.

In case of defective installation, there will be no guarantee for the PTO System and the tractor.

There will be no guarantee for damages to the PTO system caused by a defective or faulty connection of tools.

There will be no guarantee for damages caused by defective tools or damages to tools while being used.

The guarantee will be repealed in case of improper maintenance of the PTO System.

In case of damages to the Front PTO/Front-Lifts or any consequential damages, the customer will not receive any compensation for loss of profits.

The PTO System must not be exposed to extremely pulsating loads, e.g. from stump clearing equipment, stone crushers, liquid manure stirrers, etc.

Liability to a third party, including agreements entered with a third party, is not acknowledged. This also applies for installation at another tractor type carried out by a third party.

HE-VA reserves the right of design changes without previous notice, including exchange of spare parts, if these are improved. Spare parts will be stocked for equipment already delivered in accordance with the regulations applying for this.