

UK

HE-VA

Operating Instructions
Spare Parts List
Declaration of Conformity

GOOD AS IT LOOKS!

AS GOOD AS IT LOOKS!

AS GOOD AS IT LOOKS!

AS GOOD AS IT LOOKS!

AS GOOD AS IT LOOKS!

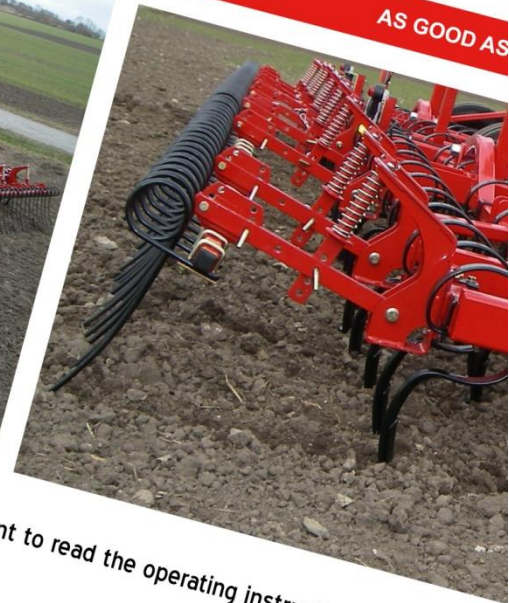
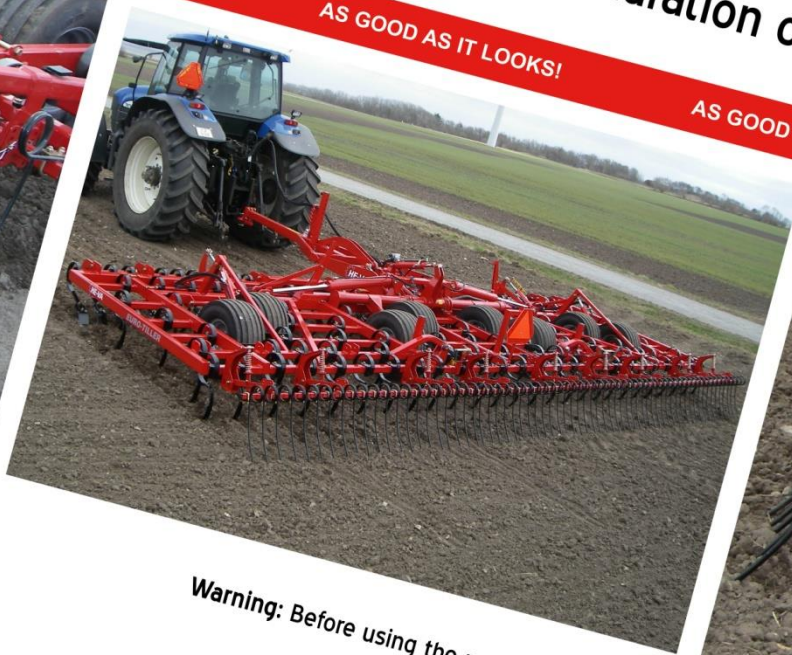

Warning: Before using the machine it is important to read the operating instructions.



N. A. Christensensvej 34
DK-7900 Nykøbing Mors
Tel: 97724288
Fax: 97722112
www.he-va.com

Euro-Tiller

Working width: 6-7-8-9-10m (from machine No 30044 to 30915)

Content

EC DECLARATION OF CONFORMITY	5
Delivery check	6
Machine description	6
Range of application	6
Technical specifications.....	6
Safety instructions for Euro-Tiller	7
Safety and instructions on hydraulics.....	8
Instructions on transport on the public roads:.....	8
Labels on the machine	9
Start-up of the machine.....	10
General information.....	10
Attachment and uncoupling	10
Maintenance	10
Lubrication.....	10
Assembly instructions.....	12
Assembling the drawbar	12
Mounting of wing sections after transport.....	12
Assembling the front-harrow	12
Assembling the wing extension	12
Assembling the long finger after-harrow.....	12
Instructions and adjustment of the harrow.....	13
Attaching the harrow	13
Adjusting the top link of the harrow	13
Adjusting the support wheels.....	13
Adjusting the levelling bar.....	14
Depth adjustment of the harrow	14
Locking device.....	15
Spare parts list	16
Drawbar	16
Middle frame	18
Wing	20
Wing extension	23
Spring-Board.....	24
Front-harrow	26
Long finger after-harrow	28
Roller	30
Erradicator Tine	32
Spare parts wheel.....	34
Clevis, rear	36

Control for wheel cylinder.....	38
Light mounting	40
Hydraulics	42
Wings.....	42
Wheel (with 3m middle frame).....	44
Wheel (with 4m middle frame).....	46
Spring-Board.....	48
Quick coupling, facing backwards – clevis rear	50
El. depth stop	52
Notes.....	53



EC DECLARATION OF CONFORMITY

in accordance with the EU Machinery Directive 2006/42/EC
applicable as from December 29th 2009:

HE-VA ApS
N. A. Christensensvej 34,
DK-7900 Nykøbing Mors

hereby confirms that the following machine has been manufactured in accordance with the Council
Directive 2006/42/EC.

The declaration comprises the following machine:

Euro-Tiller

6,0 / 7.0 / 8.0 / 9.0 / 10.0 m

No : _____

Nykøbing the 29th December 2009

A handwritten signature in black ink, which appears to read "Villy Christensen".

Villy Christensen

The undersigned is furthermore authorised to compile technical documentation for the above machine.

Delivery check

Upon delivery to the dealer/supplier as well as to the customer, check the Euro-Tiller for possible damages.

Machine description

Range of application

HE-VA Euro-Tiller is a trailed seedbed harrow which is available in 6,0m, 7.0m, 8.0m, 9.0m and 10.0m working width. Euro-Tiller is a standard harrow built up in a strong frame construction with 7 bars and 4 boogie 300/65x12 – depth / transport wheels ensuring precise harrow depth in all soil types. The harrow depth is easily adjusted centrally on the machine, and the depth wheel master-slave hydraulic system ensures a uniform working of the wheels. By means of a switch in the cabin, the driver can stop the electric depth stop enabling the manual operation of the hydraulic depth control. Euro-Tiller has a wide range of extra equipment, meaning that the harrow can be built up individually depending on the actual soil conditions and harrow tasks. In front the Euro-Tiller can be equipped with a strong front-harrow in front of the Spring-Board leveling bar, ensuring that the leveling bar can level the already loosened soil effectively. At the rear a Spring-Board after-harrow can be mounted followed by a long finger after-harrow. It is also possible to mount a long finger after-harrow separately. As a novelty HE-VA is offering a $\varnothing 400$ mm flat bar roller at the rear, leaving the field with a consolidated surface and a perfect surface finish for a sowing of for example beets.

Technical specifications

Working width	6,0m	7,0m	8,0m	9,0m	9,0m	10,0m
Center section width	3,0m	3,0m	3,0m	3,0m	4,0m	4,0m
Transport width	3,0m	3,0m	3,0m	3,0m	4,0m	4,0m
Transport heigh	2,8m	3,3m	3,8m	4,3m	3,8m	4,3m
Power required HP	120+	150+	175+	200+	200+	225+
Required no. of double acting oil outlets	4 pcs.	4 pcs.	4 pcs.	4 pcs.	4 pcs.	4 pcs.
No. of tines	69 pcs.	82 pcs.	94 pcs.	106 pcs.	106 pcs.	118 pcs.

Veight

Flat bar roller $\varnothing 400$ mm	240kg	280kg	320kg	360kg	400kg	440kg
--------------------------------------	-------	-------	-------	-------	-------	-------

Safety instructions for Euro-Tiller

Do not start-up the machine if there are persons in exposed positions* within a hazardous area**.

When persons are in exposed positions (e.g. in connection with adjustment, maintenance, attachment and uncoupling), the following conditions must be observed:

1. The machine must be lowered to firm ground.
2. The hydraulics must be relieved.
3. The tractor must be stopped and the key removed from the ignition switch.
4. The driver must ensure that no persons are in exposed positions during the operation.

* **Persons in exposed positions: Any person who is wholly or partly within a hazardous area.**

** **Hazardous area: On and under the machine within a distance of 10 m from the machine.**

Most accidents that happen in connection with the operation, transport and maintenance of machines are caused by non-compliance with the most elementary safety conditions.

Therefore it is vital that anybody working at the machine carefully complies with the safety instructions as well as other instructions applying to the machine.

The machine may only be operated, maintained and repaired by persons, who are familiar with this work and who are further familiar with the possible elements of danger with this particular machine.

CAREFUL! Rotating parts and loose-fitting clothing make up a dangerous combination.

IMPORTANT! Due to the risk of falling down, it is extremely hazardous to stand on the machine frame during operation of the machine attached to a tractor.

Safety and instructions on hydraulics

1. The maximum working pressure is 225 bar.
2. It is advisable to label the attachment parts at hydraulic connections between the tractor and the tool in order to eliminate incorrect operation!
3. When checking for hydraulic leaks, use suitable safety wear (eye protectors, gloves, etc.)
High-pressure hydraulic oil may penetrate the skin and cause dangerous injuries.
In case of injury, consult a doctor immediately. **RISK OF INFECTION!**
4. Before operating the hydraulics, lower the machine to firm ground.
Relieve the hydraulics, stop the motor and remove the ignition key.
5. Check the hydraulic hoses on a regular basis, however, every six months as a minimum due to any cracks, wear and tear, etc. Replace any defective hoses immediately.

The life of hydraulic hoses is maximum 5 years.

New hydraulic hoses must meet the manufacturer's requirements.

Instructions on transport on the public roads:

Check before transport on public roads that the attachment of the machine at the tractor is in accordance with the local rules and regulations in force (permitted total weight, permitted axle load, transport width, lights, warning signs, etc.).

Labels on the machine

On your machine there are several labels containing both practical advice and safety precautions.

Please be sure to read the labels and inform all those who operate the machine of the safety instructions in the manual.

Keep the labels clean and legible – if not they should be replaced.

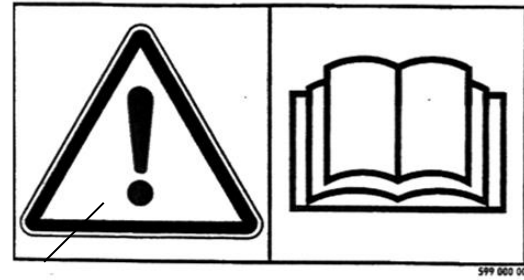

**HUSK - PLEASE NOTE -
 ACHTUNG - ATTENTION**
**EFTERSPÆND BOLTE
 TIGHTEN UP THE BOLTS
 BOLZEN NACHZIEHEN
 RESSERRER LES BOULONS**



C

D

Explanation of the labels

- A Plate with number and year of manufacture.
- B Study the Operating Instructions thoroughly before any operation of the machine and observe all safety instructions.
- C Tighten up the bolts regularly. If this is not performed, our warranty obligations will no longer apply
- D Make sure that the working area is clear before unfolding the wing sections. Never walk under a suspended section.

Start-up of the machine

General information.

The Euro-Tiller requires 2 double-acting oil outlets.

Attachment and uncoupling

From transport to working position:

1. Raise the machine to max. transport height.
2. Fold out the wing sections.
3. Adjust the working depth.

From working to transport position:

4. Raise the machine to max. transport height.
5. Fold in the wing sections. **⚠ Make sure that the wing sections are locked.**

Maintenance

- After the first 10 hours of operation, retighten the machine. Check hydraulic hoses, fittings and cylinders for leaks and retighten.
- Further check on a regular basis that all bolts are tightened.
- Before the winter storage, wash and lubricate the machine. If you use high-pressure cleaner, do not spray directly on the ball bearings. After the washing, you may spray the machine with oil.
- For permanent outdoor parking during winter harrow parked unfolded.

Lubrication

For lubrication, maintenance and repair, the Euro-Tiller must be lowered, the tractor must be braked and the motor stopped.

On all widths, Euro-Tiller has 20 lubrication points. The typical lubrication points are located at spindles, wheel bearings, wing arms, and the possible rollers have 6 lubrication points. All Euro-Tiller have to be lubricated after every 30 working hours as well as after the cleaning in order to press out any water and dirt.

Euro-Tiller 8 m with roller

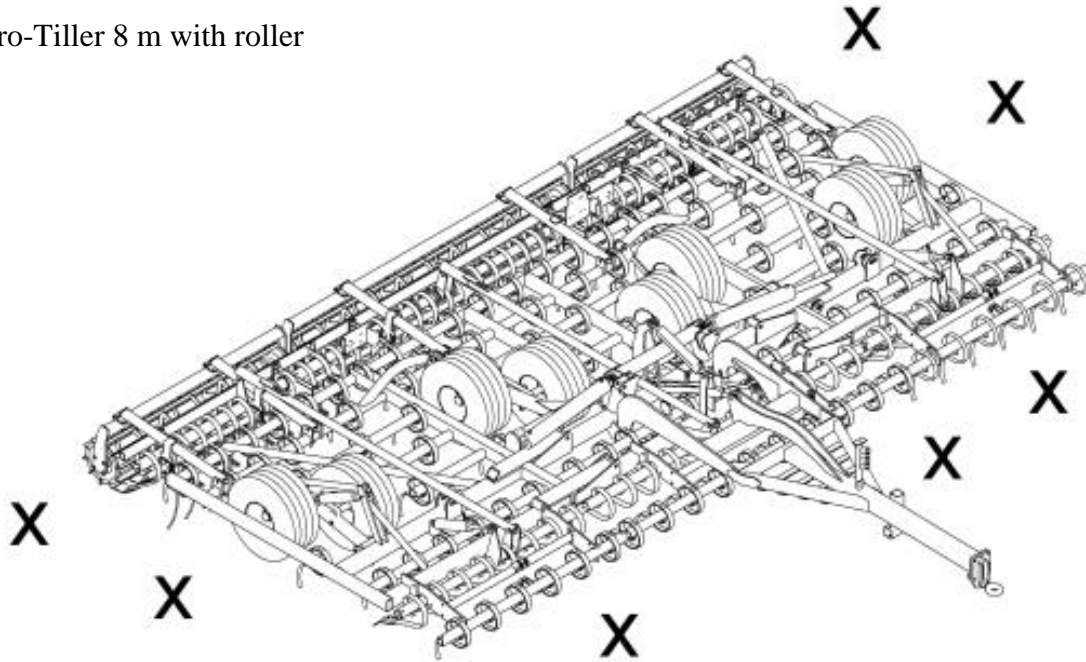

X = Lubrication point

Note! However, the double-sealed ball bearings in the roller should only be lubricated every 20 working hours and by 1-2 strokes so that the sealing rings are not pressed out.

Important! The hydraulic system is filled with oil type Hydro Texaco HD32

Assembly instructions

Assembling the drawbar.

Mount the drawbar on the middle section using bolts and bushes.
Then mount the top link on the drawbar stanchion for the middle section.
Be sure to tighten all bolts.

Mounting of wing sections after transport.

By mounting of the wing section on the middle frame, lubricate the nut without locking device with loctite and tighten it hereafter (pos. 1)



Assembling the front-harrow

Mount the leveling bars of the front-harrow using bolts and nuts. Make sure that the bearing plates of the wings are positioned on the **outer side** of the front tube supports.

The bearing plates on the middle section must be positioned on the **inner side** of the front tube supports.

Mount the hydraulic cylinder between the wing and the cylinder arm of the front-harrow.

Be sure to tighten all bolts and nuts.



Assembling the wing extension

Mount the wing extension on the wings using the flanges.

Be sure to tighten all bolts and nuts.



Assembling the long finger after-harrow.

Mount the after-harrow sections as shown on the photo. If you have chosen the option of a rear Spring-Board, the after-harrow sections must be mounted on the support bar **behind** the Spring-Board.



Instructions and adjustment of the harrow

All fundamental adjustments must be carried out on a plane surface with the harrow attached to the tractor and the wing sections lowered.

Attaching the harrow

Euro-Tiller is attached to the fixed tractor drawbar. Attach the hydraulic hoses. Please note that the hoses with blue dust caps are for lifting the harrow, and the ones with yellow dust caps are for wing folding and leveling bar.

Adjusting the top link of the harrow

Lift the middle section just enough to lift the harrow tines from the ground. Using the top link, adjust the middle section until it is parallel to the ground. Remember to tighten the lock-nut. The top link must be greased thoroughly so that fine adjustments are easily carried out.



Adjusting the support wheels

When the harrow is parallel to the ground, the support wheels must be adjusted.

The working depth is controlled by 3 hydraulic cylinders which are series connected in a master-slave system.

To ensure an even depth across the entire working width, the cylinders must be bled, reset and adjusted in relation to each other in the following way:

Raise the harrow all the way up, so that the cylinders are fully extended, and hold the lever in this position for approx. 20 seconds. In this position, the cylinders' valves allow oil to flow through the system and bleed the air out, while simultaneously resetting them. This operation should be repeated for a few seconds when attaching the machine to the tractor – after unfolding the wings but before adjusting the harrow. It should also be carried out a couple of times during the working day.

Make sure that none of the cylinder pistons are detached when carrying out adjustments. Position the stop of the master cylinder so that the harrow tines are lifted from the ground. Adjust the middle section vertically to align it with the wings by shortening / lengthening the piston rod (pos.1). If this is not sufficient, the same procedure can be done on the slave cylinders. Be careful not to turn too much.

The procedures mentioned above are fundamental: the harrow **must** be fine adjusted in the field to ensure a perfect result. The earthworks

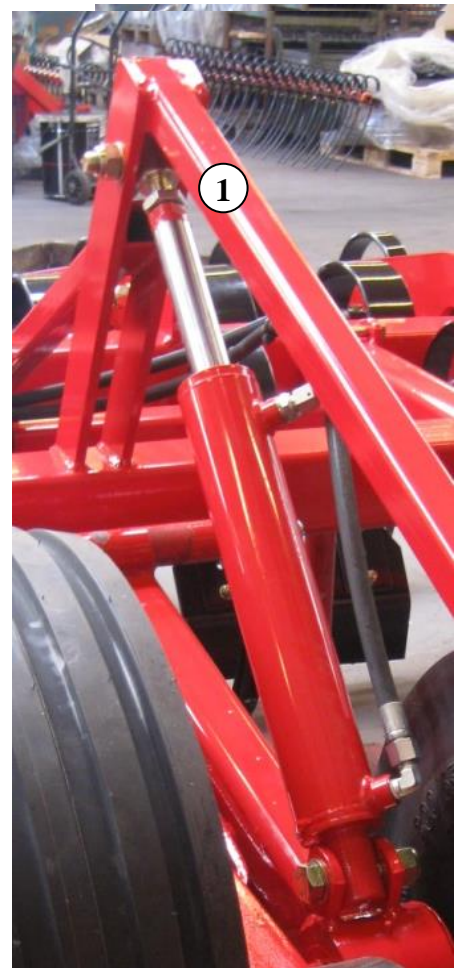

being created in front of the levelling bar should be even across the entire working width.

The piston rod end of the master cylinder should **never** be extended more than 30mm (50mm for the slave cylinders) Be sure to tighten all lock-nuts.

Make a habit of bleeding out the cylinders each time the harrow is attached to the tractor, before work, as well as a few times during the working day.

Adjusting the levelling bar.

In the field, when the harrow is lowered into working position. First, the system must be bled, in the same way as the support wheels.

Adjust the piston rods (pos. 1) so that the levelling bars are aligned. The levelling bar on the middle section may need to be adjusted 5-10mm lower, in order to eradicate the wheel tracks. When the piston rod end is extended, the leveling bar is raised, and vice versa. Do not extend the piston rod end more than 20mm.

Make a habit of bleeding out the hydraulic system each time the harrow is attached to the tractor, before work, as well as a few times during the working day. It only takes about 15 seconds.



Depth adjustment of the harrow

The depth adjustment is performed by adjusting the sensor "A" out (smaller working width) or in (bigger working depth) Loosen the thumbscrew "B", move the sensor arm "C" to the right position and tighten the thumbscrew "B" again. When the sensor activator "D" meets the sensor "A", the valve "E" will cut off for the return oil and the harrow depth will be locked. By means of the on/off switch in the cabin, the depth adjustment can be "oversteered". That is to say that the sensor activator "D" can pass the sensor "A" and a deeper work is possible e.g. on the headland.

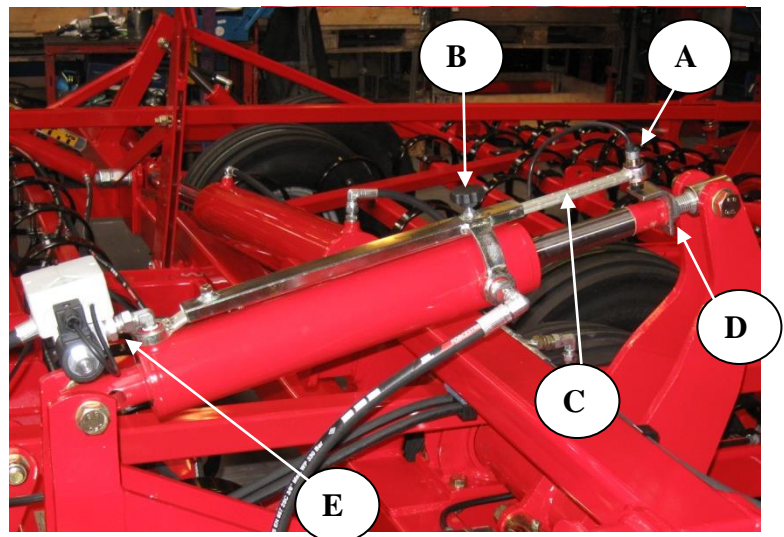

Locking device

Make sure that the wing sections are locked before transport.

Spare parts list

Drawbar

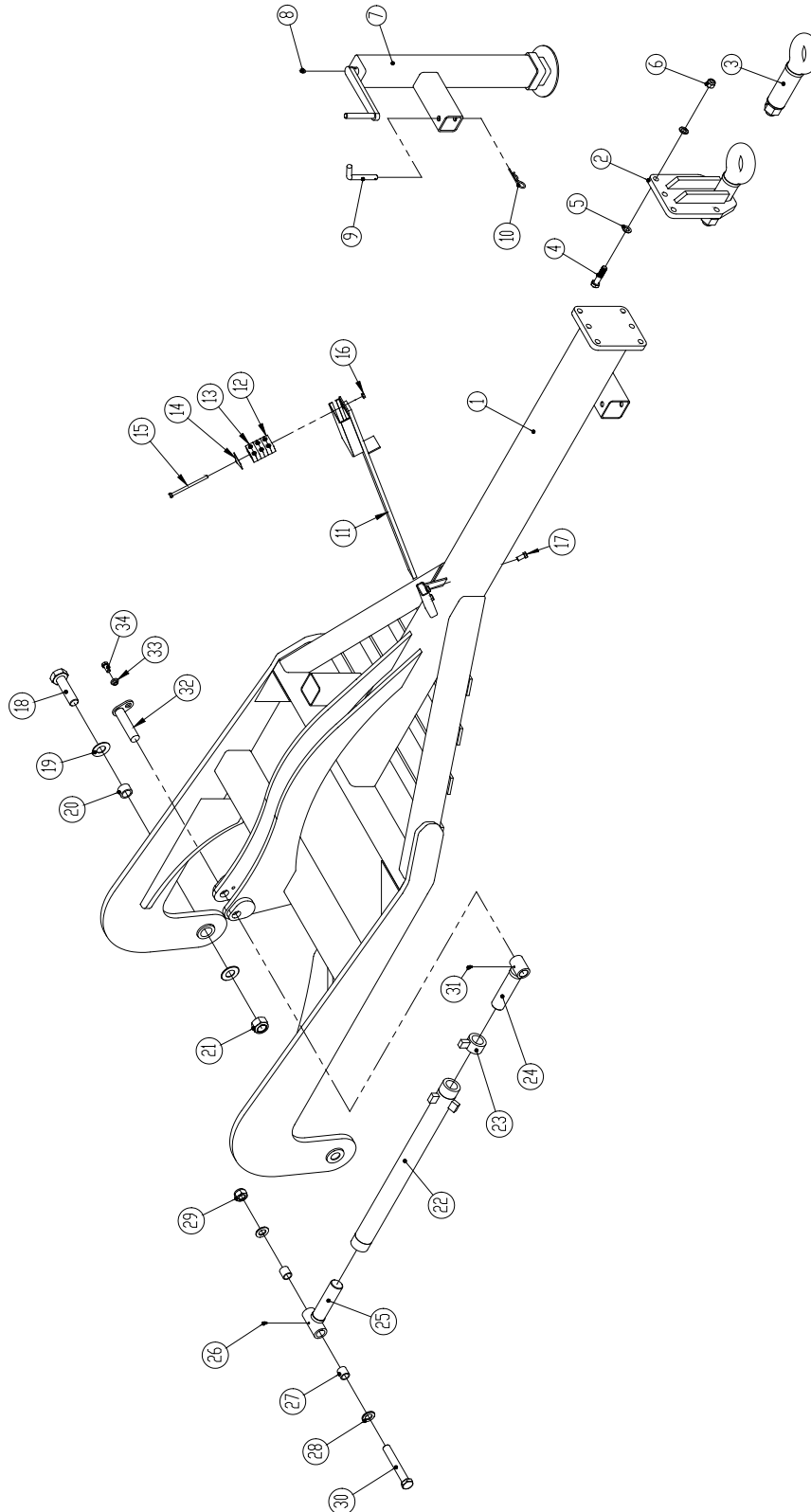

Pos.	Item no.	Designation	Number
1	1170563	Drawbar	1
2	630757028	Complete draw unit with pivotal towing eye Ø50	1
3	690141211	Towing eye Ø50	
4	0235860	Bolt M16x70 mm 8.8	
5	0272290	Facet plate Ø16	
6	0264090	Self-locking nut M16	
7	1170303	Support leg with spindle	1
8	0432500	Lubricating nipple M8	1
9	1030280	Pin Ø16x150 mm	1
10	0377400	R-clip Ø4	1
11	630771200	Hose clamp	
12	0449650	Tube-support double Ø15-Ø15	2
13	0449600	Tube-support double Ø18-Ø18	1
14	0449610	Top plate	1
15	0234990	Bolt M8x120mm	
16	0264050	Self-locking nut M8	
17	0235040	Bolt M10x25mm	
18	0237010	Bolt M30x120mm. 8.8	
19	0272350	Facet plate Ø30	
20	0475307	I-Bush EG Ø40/Ø30x25 mm	2
21	0264155	Self-locking nut M30	
22	1170262	Top link	1
23	1170302	Lock-nut	1
24	1170300	Threaded rod with right-thread	1
25	1170299	Threaded rod with left-thread	1
26	0432120	Lubricating nipple M6 - 45°	1
27	0475300	I-Bush EG Ø30/Ø24x30 mm	2
28	0272330	Facet plate Ø24	
29	0264130	Self-locking nut M24	
30	0236470	Bolt M24x160mm. 8.8	
31	0432100	Lubricating nipple M6	1
32	69430130G	Pin Ø30 L=130mm	1
33	630532600	Bush for M12	1
34	0235330	Set screw M12x25 mm	

Middle frame

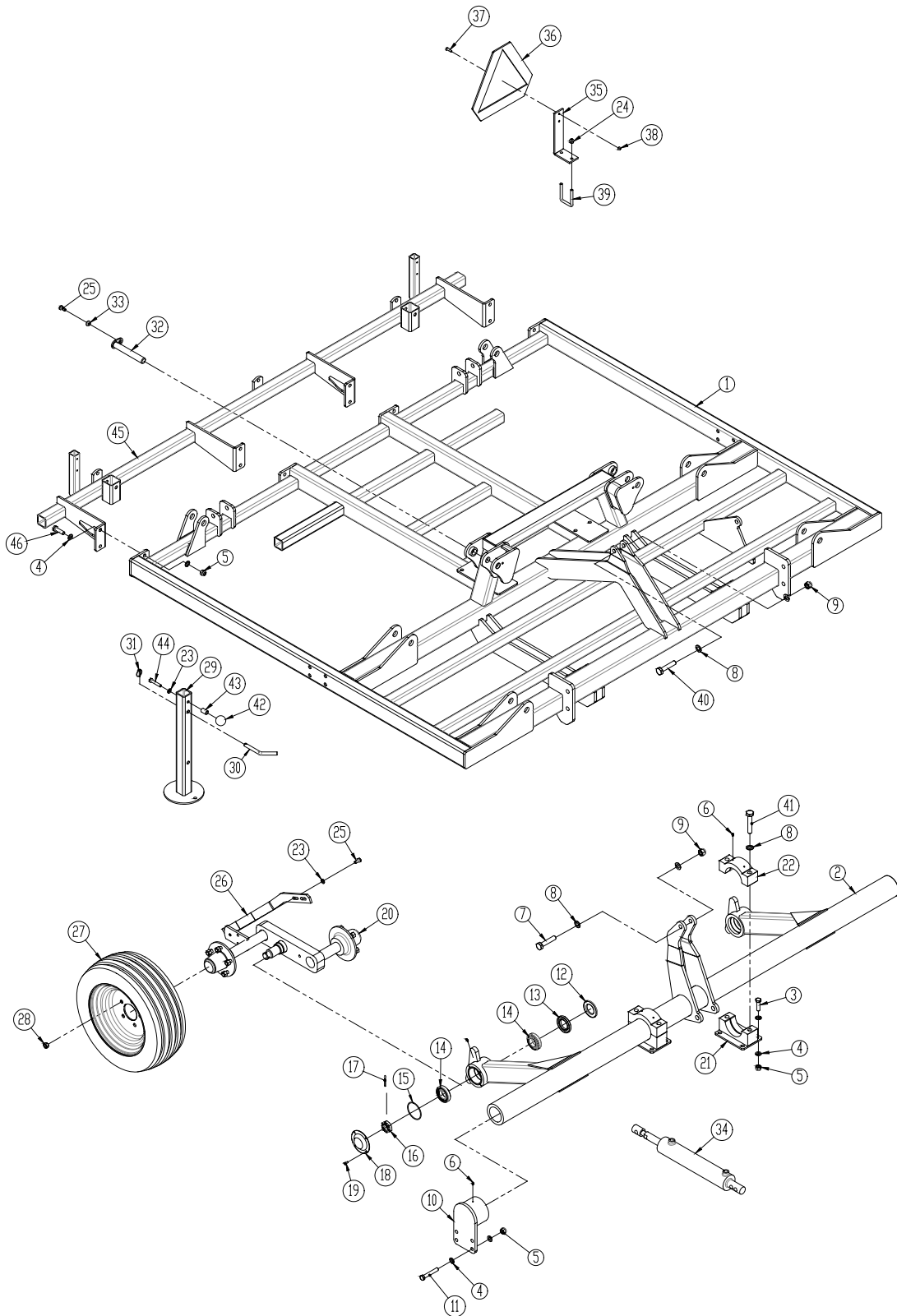

Pos.	Item no.	Designation	3 m Middle frame	4 m Middle frame
1	1170603	Middle frame	1	
	1170650	Middle frame		1
2	1170022	Wheel frame	1	
	1170233	Wheel frame		1
3	0235820	Set screw M16x45 mm 8.8		
4	0272290	Facet plate Ø16		
5	0264090	Self-locking nut M16		
6	0432100	Lubricating nipple M6	6	8
7	0236200	Bolt M20x110 mm 8.8		
8	0272310	Facet plate Ø20		
9	0264110	Self-locking nut M20		
10	1170024	Bearing	2	2
11	0235900	Bolt M16x100 mm 8.8		
12	0483380	Sealing disc Z011	2	2
13	0483590	Sealing ring Ø90/Ø55x10 mm	2	2
14	0479000	Roller bearing	4	4
15	0483750	O-ring Ø91, 67x3.,53	2	2
16	0262480	Castellated nut M36x1.5	2	2
17	0373350	Split-pin Ø5x50	2	2
18	1113400	Bearing cover	2	2
19	0234280	Set screw M6x16 mm 8.8		
20	1170015	Boogie hub	2	2
21	1170497	console (bottom)	2	2
22	1170441	Konsol (top)	2	2
23	0272270	Facet plate Ø12		
24	0264070	Self-locking nut M12		
25	0235330	Set screw M12x25 mm 8.8		
26	1170188	Scraper f/left buggy wheels	1	1
	1170319	Scraper f/right buggy wheels	1	1
27	0395650	Complete wheel Ø300/65-12/8	2	2
28	0261390	Nut M16 8.8		
29	1170534	Support leg	2	2
30	1030280	Pin Ø16x150 mm	2	2
31	0378200	Ring split Ø4.5	2	2
32	69430200g	Pin Ø30x200	2	2
33	630532600	Bush for M12	2	2
34	0468600	Hydr. cylinder Ø85/75– length of stroke: Ø35x328 mm. (for machine No 28966)	1	2
	0468600	Hydr. cylinder Ø85/75– length of stroke: Ø35x312 mm. (from machine No 28967)	1	2
35	1170531	Holder for warning triangle	1	1
36	0521010	Warning triangle	1	1
37	0234760	Set screw M8x25 mm 8.8		
38	0264050	Self-locking nut M8		
39	0382130	U-bolt M12 for 60x60	1	1
40	0236200	Bolt M20x110 mm st 8.8		
41	0236180	Bolt M20x90 mm st 8.8		

Pos.	Item no.	Designation	3 m Middle frame	4 m Middle frame
42	0489060	Handle	2	2
43	1105450	Bush	2	2
44	0235410	Bolt M12x60 mm		
45	1170607	Bar behind middle frame	1	
	1170649	Bar behind middle frame		1
46	0235830	Bolt M16 x 55		

Wing

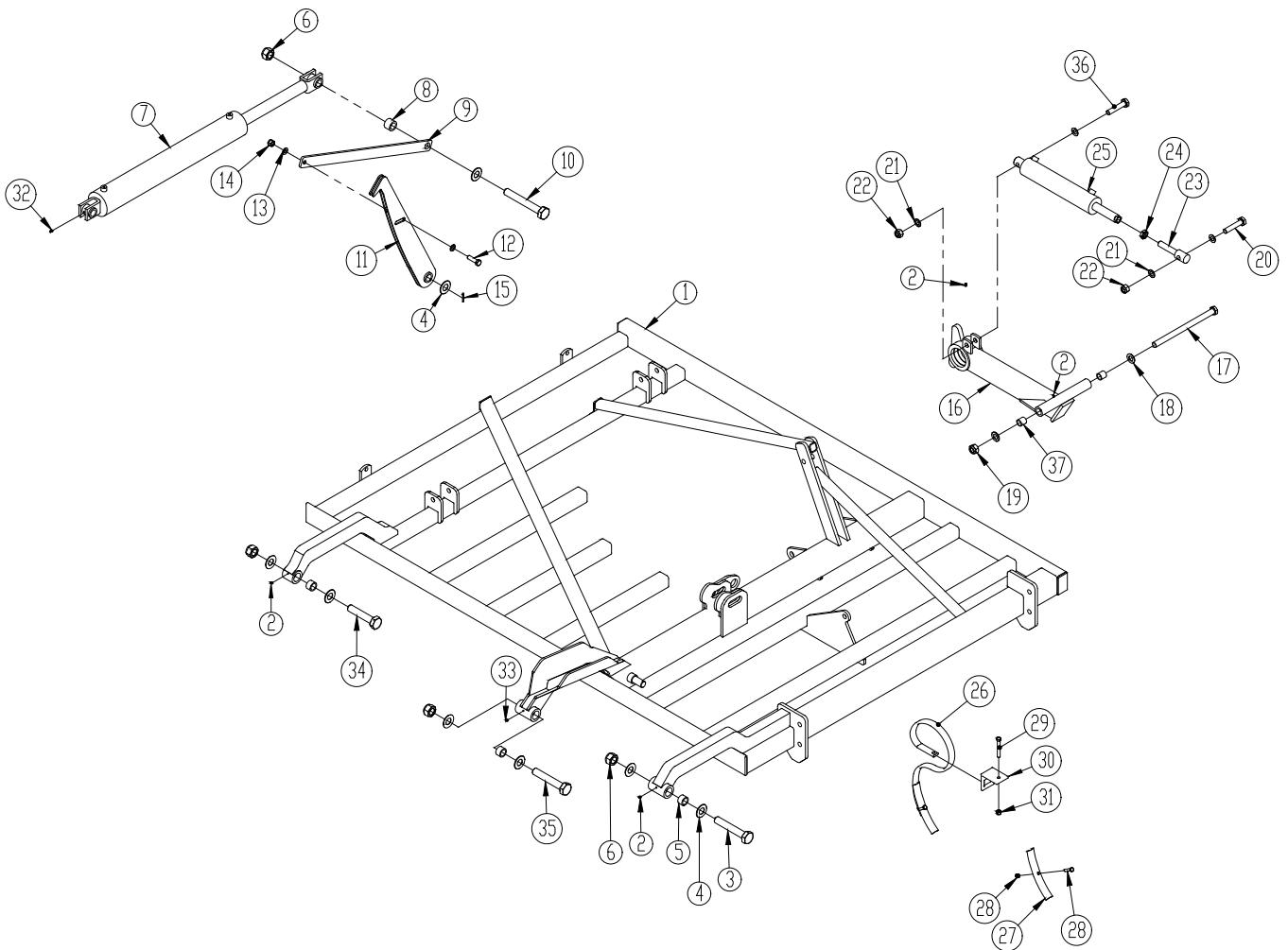

Pos.	Item no.	Designation	6 m	7 m	8 m	9 m-3 m middle sec.	9 m-4 m middle sec.	10 m
1	1170641	Wing (L)	1					
	1170643	Wing (R)	1					
	1170567	Wing (L)		1	1	1	1	1
	1170565	Wing (R)		1	1	1	1	1
2	0432100	Lubricating nipple M6	8	8	8	8	8	8
3	0237070	Bolt M30x180 mm. 8.8						
4	0272350	Facet plate Ø30						
5	0475307	I-Bush EG Ø40/Ø30x25 mm	6	6	6	6	6	6
6	0264155	Self-locking nut M30						
7	0463105	Hydraulic cylinder Ø100/50x730 mm	2	2				
	0463109	Hydraulic cylinder Ø110/50x730 mm			2		2	
	0463110	Hydraulic cylinder Ø120/50x730 mm				2		2
8	1170255	Distance bush Ø45/Ø31x32 mm	2	2	2	2	2	2
9	1170182	Drawbar for wing locking device	2	2	2	2	2	2
10	0237090	Bolt M30x220 mm 8.8						
11	1170160	Wing locking device	2	2	2	2	2	2
12	0235830	Bolt M16x55 mm 8.8						
13	0272290	Facet plate Ø16						
14	0264090	Self-locking nut M16						
15	0373180	Split-pin Ø4x40 mm	2	2	2	2	2	2
16	1170045	Boogie arm (L)	1	1	1	1	1	1
	1170046	Boogie arm (R)	1	1	1	1	1	1
17	0236560	Bolt M24x360 mm 8.8						
18	0272330	Facet plate Ø24						
19	0264130	Self-locking nut M24						
20	0236250	Bolt M20x160 mm 8.8						
21	0272310	Facet plate Ø20						
22	0264110	Self-locking nut M20						
23	1112900	Threaded end f/cylinder	2	2	2	2	2	2
24	0261430	Lock-nut M24x3.0 mm		2	2	2	2	2
25	0468701	Hydraulic cylinder Ø80/70x295 mm (for machine No 28966) left		1	1	1	1	1
	0468702	Hydraulik cylinder Ø80/70x279mm. (from machine No 28967) left	1	1	1	1	1	1
	0468501	Hydraulik cylinder Ø70/60x300mm. (for machine No 28966) right		1	1	1	1	1
	0468502	Hydraulik cylinder Ø70/60x284mm. (from machine No 28967) right	1	1	1	1	1	1
26	0422131	Complete tine 45x10 mm	69	83	95	106	106	118
27	0422030	Reversible point	69	83	95	106	106	118
28	0386220	Cultivator bolt M10x45 w/nut 8.8						
29	0235460	Bolt M12x100mm. 8.8						
30	0422369	Tine support for tine 45x10 mm	69	83	95	106	106	118

Pos.	Item no.	Designation	6 m	7 m	8 m	9 m-3 m middle sec.	9 m-4 m middle sec.	10 m
31	0264070	Self-locking nut M12						
32	0432130	Lubricating nipple M6 – 90°	2	2	2	2	2	2
33	0432120	Lubricating nipple M6 – 45°	2	2	2	2	2	2
34	0237030	Bolt M30x140 mm 8.8						
35	0237050	Bolt M30x160 mm 8.8						
36	0236180	Bolt M20x90 mm 8.8						
37	0475300	I-Bush EG Ø30/Ø24x30 mm	2	2	2	2	2	2

Wing extension

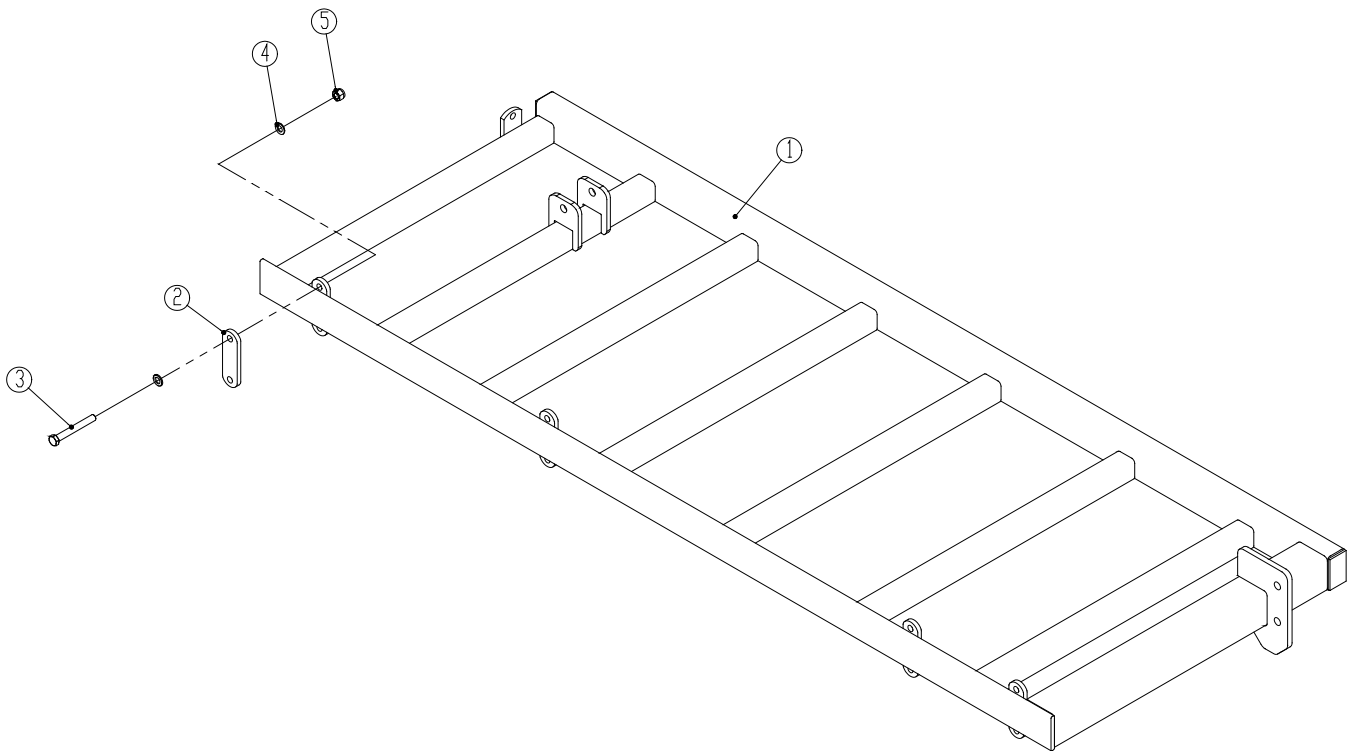

Pos.	Item no.	Designation	Number
1	1170616	Wing 0.5 m (L)	1
	1170646	Wing 0.5 m (R)	1
	1170647	Wing 1.0 m (L)	1
	1170648	Wing 1.0 m (R)	1
2	1170200	Clamping plate	8
3	0235920	Bolt M16x120 mm 8.8	
4	0272290	Facet plate Ø16	
5	0264090	Self-locking nut M16	

Spring-Board

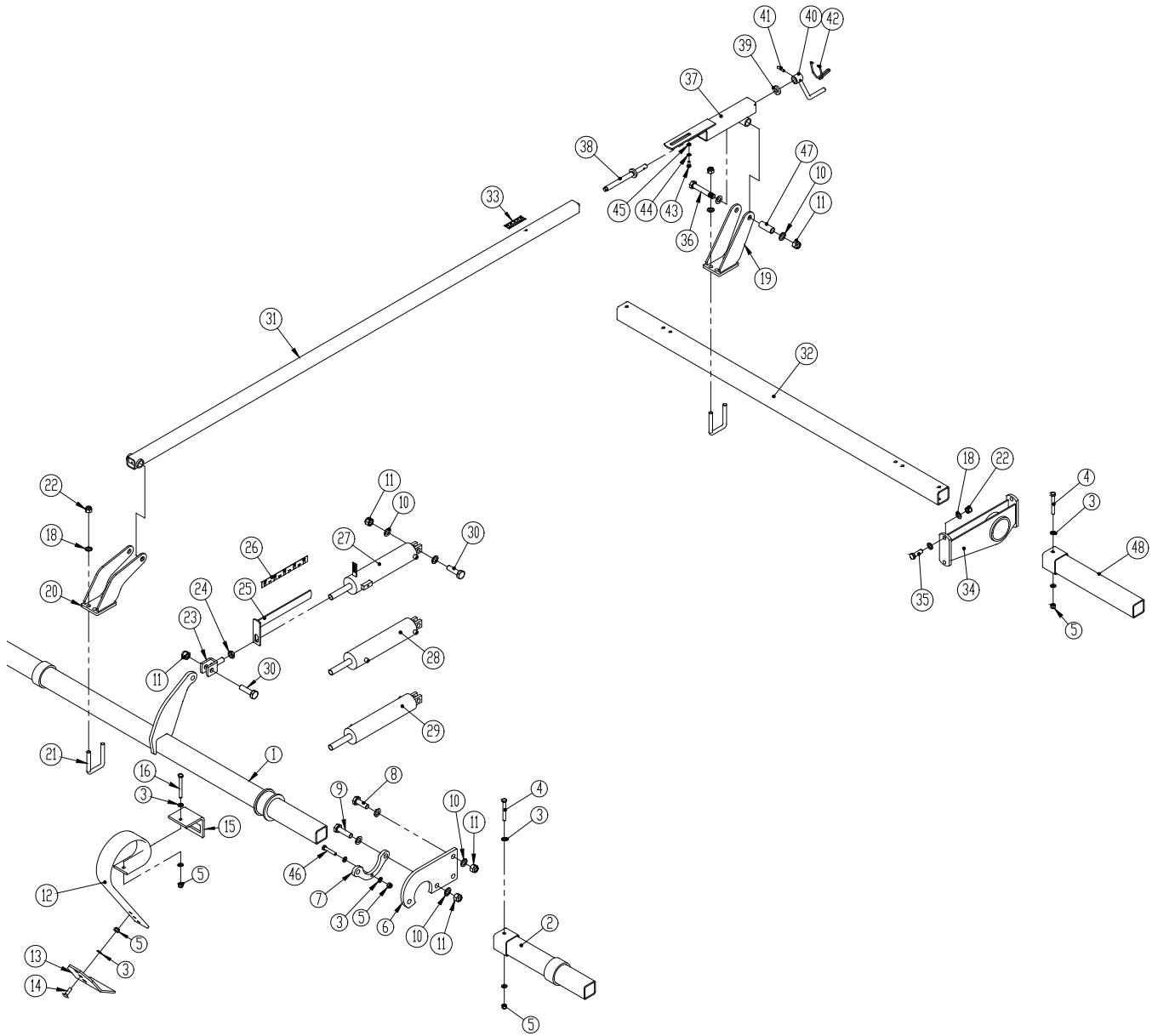

Pos.	Item no.	Designation	6 m	7 m	8 m	9 m- 3 m middle sec.	9 m- 4 m middle sec.	10m
1	1170651	Bar for wing 1,5 m (L)	1					
	1170652	Bar for wing 1,5 m (R)	1					
	1170546	Bar for wing 2 m (R)		1	1	1	1	1
	1170551	Bar for wing 2 m (L)		1	1	1	1	1
	1170547	Bar for middle frame 3 m	1	1	1	1		
	1170559	Bar for middle frame 4 m					1	1
2	1170521	Bar extension 0.5 m			2		2	
	1170524	Bar extension 1.0 m				2		2
3	0272270	Facet plate Ø12						
4	0235460	Bolt M12x100 mm 8.8						
5	0264070	Self-locking nut M12						
6	1170523	Arm	6	6	8	8	10	10
7	1170499	Locking device	12	12	16	16	20	20
8	0236130	Set screw M20x60 mm 8.8						
9	0236160	Bolt M20x75 mm 8.8						
10	0272310	Facet plate Ø20						
11	0264110	Self-locking nut M20						
12	0422140	Spring-Board tine 45x10 mm	29	35	41	47	47	53
	0422145	Spring-Board tine 80x10 mm	24	28	32	36	36	40
13	0422141	Wearing plate 100x8 mm	29	35	41	47	47	53
	0422143	Wearing plate 150x8 mm	24	28	32	36	36	40
14	0248660	Bolt (carrier bolt) M12x40 8.8						
15	0422368	Tine support, tine 45x10 mm	29	35	41	47	47	53
	0422390	Tine support, tine 80x10 mm	24	28	32	36	36	40
16	0235470	Bolt M12x110 mm 8.8						
17	0235920	Bolt M16x120 mm 8.8						
18	0272290	Facet plate Ø16						
19	1170115	Guideway	3	3	3	3	3	3
20	1170504	Guideway	3	3	3	3	3	3
21	0382150	U-bolt M16 for 70x70	12	12	12	12	12	12
22	0264090	Self-locking nut M16						
23	1114090	Fork	3	3	3	3	3	3
24	0261411	Lock-nut M20 8.8						
25	1113740	Scale	1	1	1	1	1	1
26	0652560	Scale transfer	1	1	1	1	1	1
27	0468800	Hydraulic cylinder Ø70/60x265 mm	1	1	1	1	1	1
28	0468900	Hydraulic cylinder Ø80/70x260 mm	1	1	1	1	1	1
29	0469000	Hydraulic cylinder Ø75/65x260 mm	1	1	1	1	1	1
30	0236140	Bolt M20x65 mm 8.8						
31	1170561	Inner tube	3	3	3	3	3	3
32	1170373	Bar for wing 1,5 m	2					
	1170500	Bar for wing 2 m		2	2	2	2	2
	1170087	Bar for middle frame 3 m	1	1	1	1		
	1170241	Bar for middle frame 4 m					1	1
33	0652550	Scale transfer	3	3	3	3	3	3
34	1170098	Bearing for springboard	7	7	7	9	10	10
35	0235810	Set screw M16x50 mm 8.8						
36	0236210	Bolt M20x120 mm 8.8						
37	1115720	Outer tube	3	3	3	3	3	3
38	1034460	Spindle	3	3	3	3	3	3
39	1011410	Stop ring	3	3	3	3	3	3
40	1011420	Crank	3	3	3	3	3	3
41	0371660	Roll pin Ø8x32 mm	3	3	3	3	3	3

Pos.	Item no.	Designation	6 m	7 m	8 m	9 m- 3 m middle sec.	9 m- 4 m middle sec.	10m
42	0431980	Spindle keeper Ø5	3	3	3	3	3	3
43	0234831	Set screw M8x65 mm 8.8						
44	0272250	Facet plate Ø8						
45	0264050	Self-locking nut M8						
46	0235420	Bolt M12x70						
47	1170540	Bush	6	6	6	6	6	6
48	1170213	Bar extension 0.5 m			2		2	
	1170213	Bar extension 1.0 m				2		2

Front-harrow

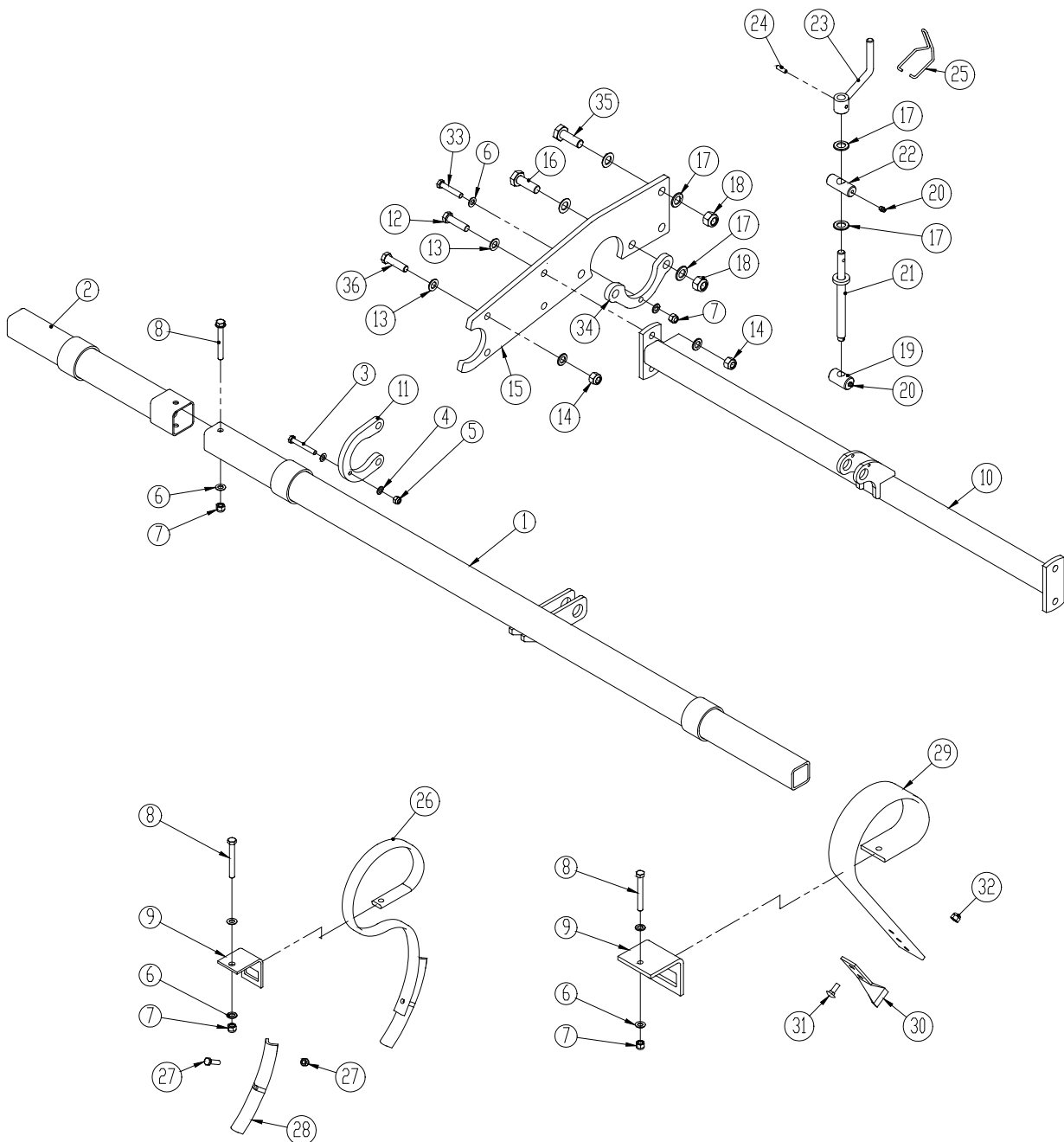

Pos.	Item no.	Designation	6 m	7 m	8 m	9 m- 3 m middle sec.	9m- 4 m middle sec.	10 m
1	1170549	Bar for middle frame 3 m	1	1	1	1		
	1170560	Bar for middle frame 4 m					1	1
	1170553	Bar for wing 1,5 m (L)	1					
	1170554	Bar for wing 1,5 m (R)	1					
	1170548	Bar for wing 2 m (L)		1	1	1	1	1
	1170550	Bar for wing 2 m (R)		1	1	1	1	1
2	1170520	Bar extension 0.5 m			2		2	
	1170525	Bar extension 1 m				2		2
3	0235130	Bolt M10x70 mm 8.8						
4	0272260	Facet plate Ø10						
5	0264060	Self-locking nut M10						
6	0272270	Facet plate Ø12						
7	0264070	Self-locking nut M12						
8	0235460	Bolt M12x100 mm 8.8						
9	0422369	Tine support for tine 45x10 mm	24	28	32	36	36	40
10	1170129	Spindle bar for middle frame	1	1	1	1	1	1
	1170380	Spindle bar for wing (L)	1					
	1170392	Spindle bar for wing (R)	1					
	1170137	Spindle bar for wing		2	2	2	2	2
11	1170545	Locking device	12	12	16	16	20	20
12	0235830	Bolt M16x55 mm 8.8						
13	0272290	Facet plate Ø16						
14	0264090	Self-locking nut M16						
15	1170544	Arm	6	6	8	8	10	10
16	0236160	Bolt M20x75 mm 8.8						
17	0272310	Facet plate Ø20						
18	0264110	Self-locking nut M20						
19	1012300	Spindle nut	3	3	3	3	3	3
20	0432500	Lubricating nipple M8	6	6	6	6	6	3
21	1115410	Spindle	3	3	3	3	3	3
22	1011470	Bearing for spindle	3	3	3	3	3	3
23	1036260	Crank	3	3	3	3	3	3
24	0371660	Roll pin Ø8x32 mm	3	3	3	3	3	3
25	0431980	Spindle keeper Ø5	3	3	3	3	3	3
26	0422131	Complete tine 45x10 mm	21	25	29	33	33	37
27	0386220	Cultivator bolt M10x45 8.8	21	25	29	33	33	37
28	0422030	Reversible point	21	25	29	33	33	37
29	0422148	Spring-Board tine 45x10 mm	21	25	29	33	33	37
30	0422142	Twisted point	21	25	29	33	33	37
31	0248421	Bolt (carrier bolt) M10x30 mm 8.8						
32	0264060	Self-locking nut M10						
33	0235420	Bolt M12x70						
34	1170499	Locking device	12	12	16	16	20	20
35	0236130	Bolt M20x60mm. 8.8						
36	0235870	Bolt M16x75mm. 8.8						

Long finger after-harrow

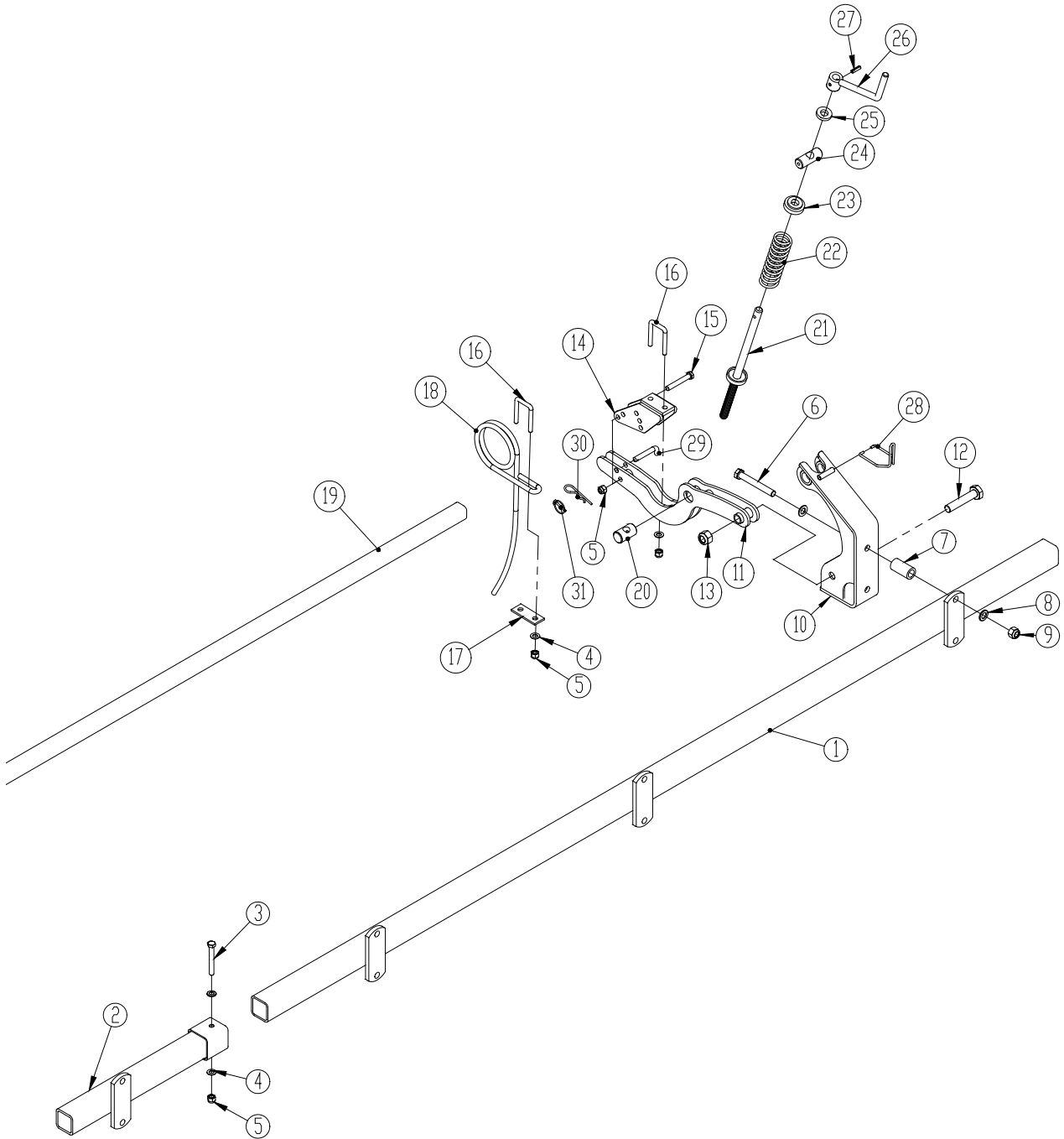

Pos.	Item no.	Designation	6 m	7 m	8 m	9 m -3 m middle sec.	9 m -4 m middle sec.	10 m
1	1170125	Bar for middle frame 3 m	1	1	1	1		
	1170254	Bar for middle frame 4 m					1	1
	1170375	Bar for wing 1,5 m	2					
	1170106	Bar for wing 2 m		2	2	2	2	2
2	1170269	Bar extension 0.5 m			2		2	
	1170266	Bar extension 1 m				2		2
3	0235450	Bolt M12x90 mm 8.8						
4	0272270	Facet plate Ø12						
5	0264070	Self-locking nut M12						
6	0235920	Bolt M16x120 mm 8.8						
7	1170320	Bush Ø31,8/Ø21x60mm.	14	14	18	18	20	20
8	0272290	Facet plate Ø16						
9	0264090	Self-locking nut M16						
10	1170455	Guideway	7	7	9	9	10	10
11	1170468	Arm	7	7	9	9	10	10
12	0236170	Bolt M20x80						
13	0264110	Self-locking nut M20						
14	1170469	Adjustment assembly	7	7	9	9	10	10
15	0235430	Bolt M12x75mm. 8.8						
16	0382120	U-bolt M12 for 40x40	120	140	160	180	180	200
17	1012520	Clamping plate	60	70	80	90	90	100
18	0426125	Long finger tine Ø12x100 curved	60	70	80	90	90	100
19	1170122	Bar for middle frame 3 m	1	1	1	1		
	1170286	Bar for middle frame 4 m					2	2
	1170401	Bar for wing 1,5 m	2					
	1170118	Bar for wing 2 m		2				
	1170238	Bar for wing 2.5 m			2		2	
	1170240	Bar for wing 3 m				2		2
20	1012300	Spindle nut	7	7	9	9	10	10
21	1170467	Spindle	7	7	9	9	10	10
22	0431250	Springs	7	7	9	9	10	10
23	1170460	Plate	7	7	9	9	10	10
24	1011470	Bearing for spindle	7	7	9	9	10	10
25	1011410	Stopring	7	7	9	9	10	10
26	1011420	Crank	7	7	9	9	10	10
27	0371660	Roll pin Ø8x32 mm	7	7	9	9	10	10
28	0431980	Spindle keeper Ø5	7	7	9	9	10	10
29	1170478	Pin Ø12 L=58	14	14	18	18	20	20
30	0377400	R-clip Ø4	7	7	9	9	10	10
31	0378200	Ring split Ø4,5	7	7	9	9	10	10

Roller

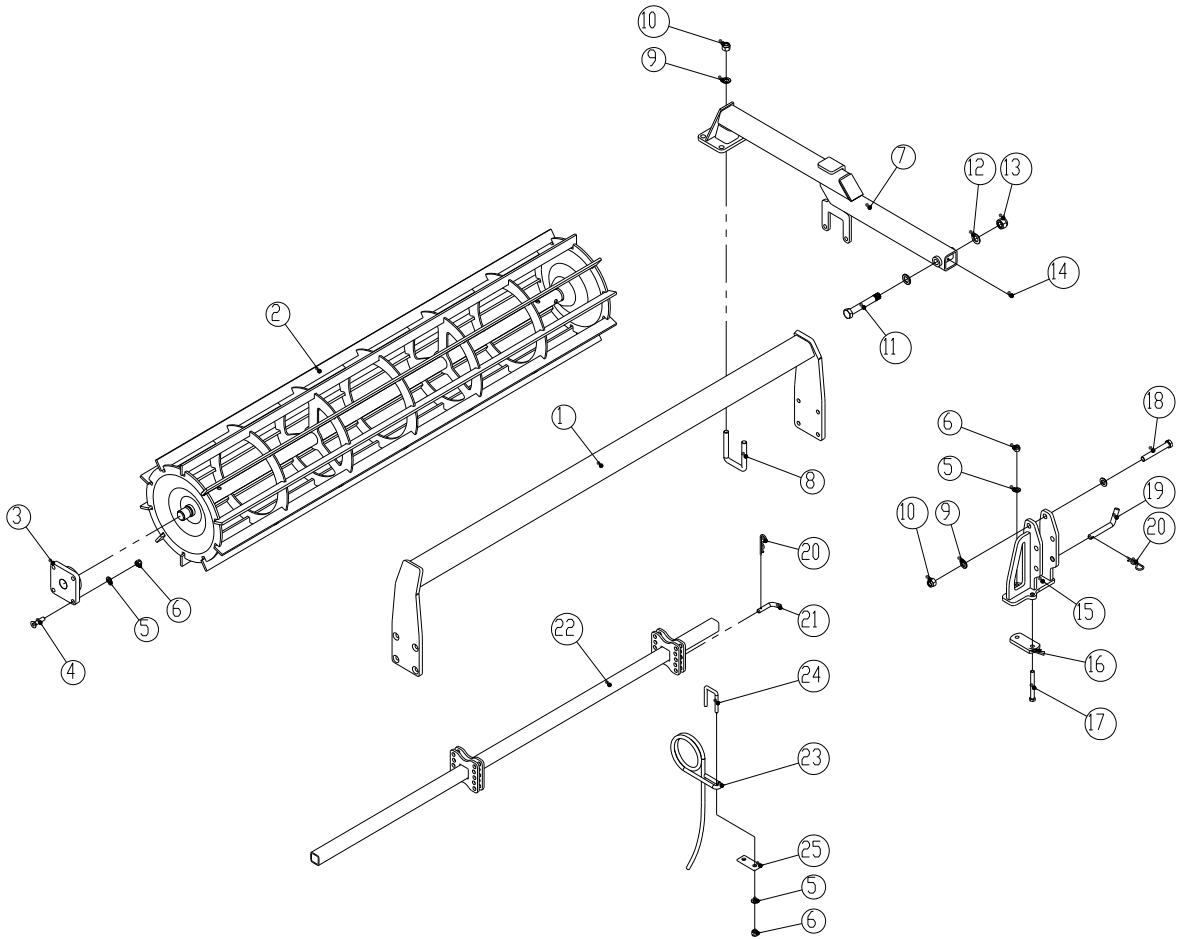

Pos.	Item no.	Designation	6 m	7 m	8 m	9 m -3 m middle sec.	9 m - 4 m middle sec.	10 m
1	1170434	Roller bar 1,5 m	2					
	1170166	Roller bar 2 m		2				
	1170229	Roller bar 2.5 m			2		2	
	1170156	Roller bar 3 m	1	1	1	3		2
	1170308	Roller bar 4 m					1	1
2	1170435	Roller 1,5 m	2					
	1170170	Roller 2 m		2				
	1170231	Roller 2.5 m			2		2	
	1170153	Roller 3 m	1	1	1	3		2
	1170310	Roller 4 m					1	1
3	0478700	Flange bearing Ø35 UCF207	6	6	6	6	6	6
4	0228100	Countersunk hexagon screw 12x50mm						
5	0272270	Facet plate Ø12						
6	0264070	Self-locking nut M12						
7	1170668	Roller arm (L)	3	3	3	3	3	3
	1170669	Roller arm (R)	3	3	3	3	3	3
8	0382150	U-bolt M16 for 70x70	6	6	6	6	6	6
9	0272290	Facet plate Ø16						
10	0264090	Self-locking nut M16						
11	0236230	Bolt M20x140 mm 8.8						
12	0272310	Facet plate Ø20						
13	0264110	Self-locking nut M20						
14	0432100	Lubricating nipple M6	6	6	6	6	6	6
15	1170270	Locking device for roller arm (L)	3	3	3	3	3	3
	1170318	Locking device for roller arm (R)	3	3	3	3	3	3
16	1057670	Clamping plate	6	6	6	6	6	6
17	0235470	Bolt M12x110 8.8						
18	0235920	Bolt M16x120 mm 8.8						
19	1030280	Pin Ø16x150 mm	4	4	4	4	4	4
20	0377400	R-clip Ø4						
21	1011580	Pin Ø13x95 mm	6	6	6	6	6	6
22	1170176	Long finger bar 3 m (Middle frame)	1	1	1	1		
	1170239	Long finger bar 4 m (Middle frame)					1	1
	1170439	Long finger bar 1,5 m (Wing)	2					
	1170667	Long finger bar 2 m (Wing)		2				
	1170237	Long finger bar 2.5 m (Wing)			2		2	
	1170326	Long finger bar 3 m (Wing)				2		2
23	0426125	Long finger tine Ø12x100 curved	60	70	80	90	90	100
24	0382120	U-bolt M12 for 40x40	60	70	80	90	90	100
25	1012520	Clamping plate	60	70	80	90	90	100

Erradicator Tine

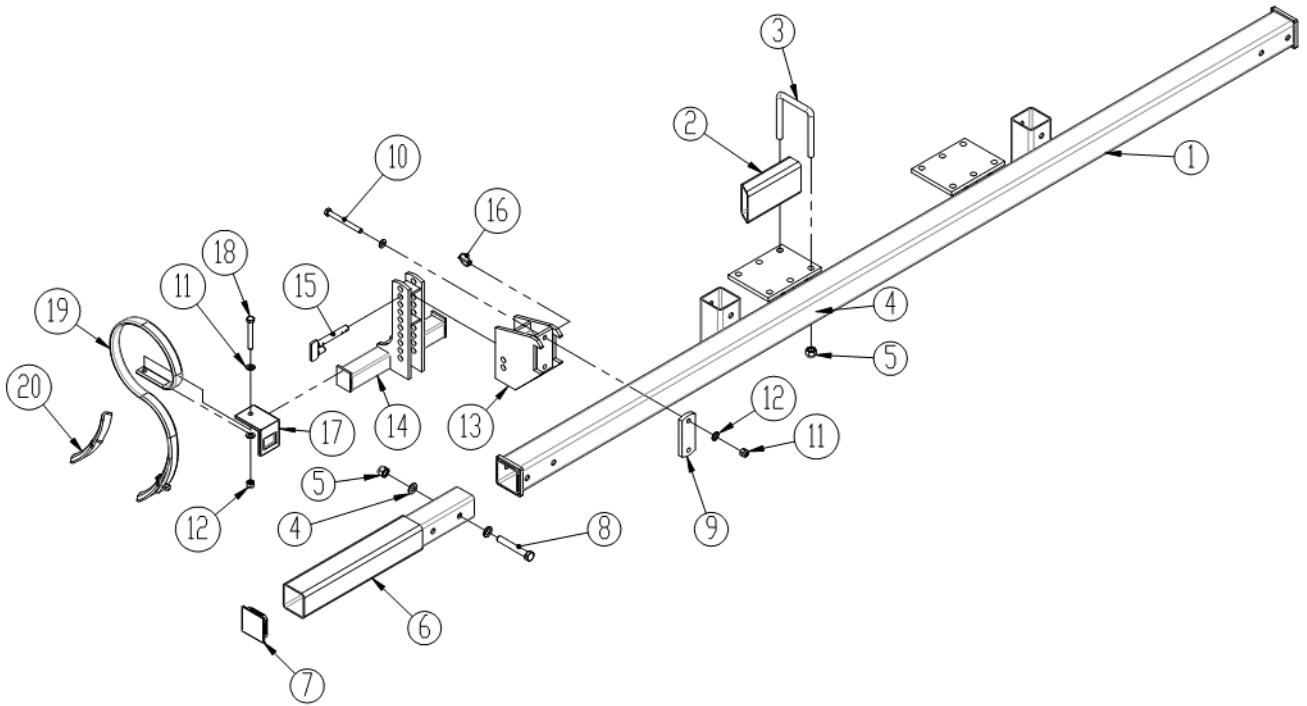

Pos.	Item no.	Designation	Number
1	1170344	Bar	1
2	1170431	Tube f/erradicator tine	2
3	0382160	U-bolt	6
4	0272290	Facet plate Ø16	
5	0264090	Self-locking nut M16	
6	1170343	Bar extension	2
7	0489620	Plug	2
8	0235910	Bolt M16x110	
9	1053691	Clamping plate	4
10	0235480	Bolt M12x120	
11	0272270	Facet plate Ø12	
12	0264070	Self-locking nut M12	
13	1053710	Guideway	4
14	1170398	Bar	4
15	1053650	Pin	4
16	0378200	Ring split ø 4,5mm	4
17	0422370	Tine support, tine 45x10 mm	8
	0422371	Tine support, tine 45x12 mm	8
18	0235450	Bolt M12x90	
19	0422131	Complete tine 45x10 mm	8
	0422170	Complete tine 45x12 mm	8
20	0422030	Reversible point (45x10)	8
	690152025	Reversible point (45x12)	8

Spare parts wheel

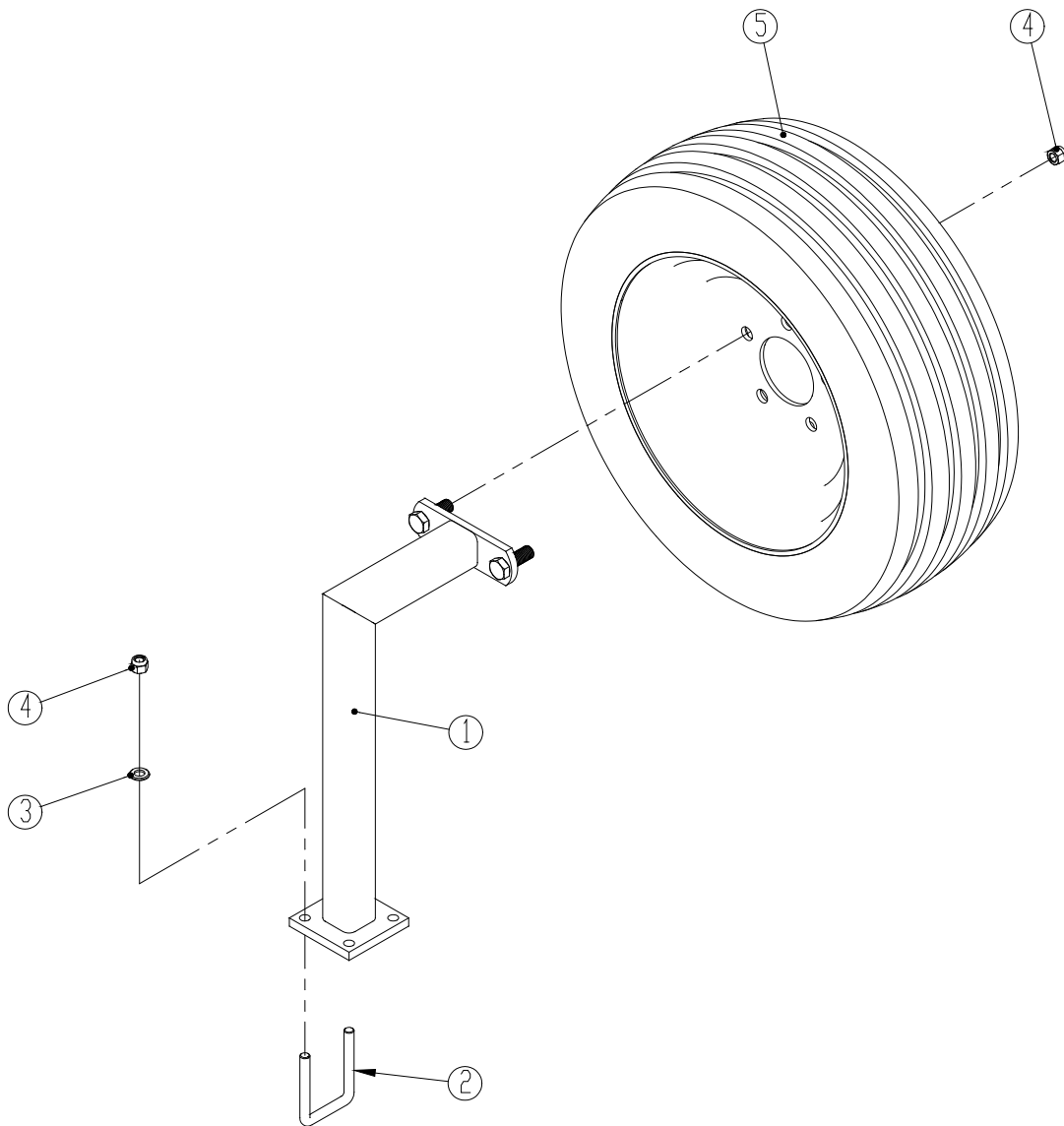

Pos.	Item no.	Designation	Number
1	1170290	Holder	1
2	0382130	U-bolt M12 for 60x60	1
3	0272270	Facet plate Ø12	
4	0264070	Self-locking nut M12	
5	0395650	Complete wheel Ø300/65-12/8	1

Clevis, rear

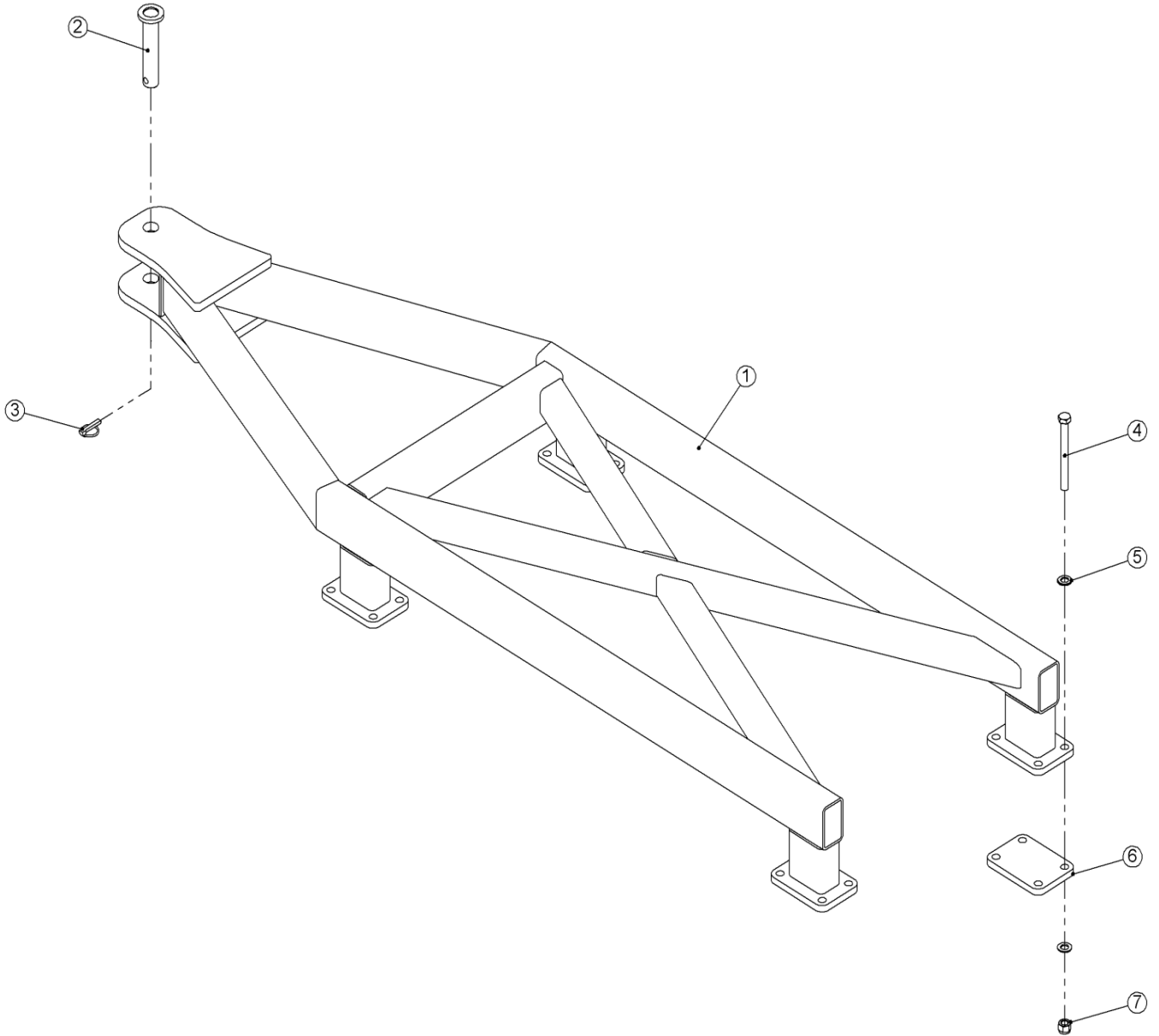

Pos.	Item no.	Designation	Number
1	1170275	Clevis rear, short (3m midsection)	1
	1170422	Clevis rear, long (3m midsection)	1
		Clevis rear, short (4m midsection)	1
	1170488	Clevis rear, long (4m midsection)	1
2	1135310	Pin Ø32x165 mm	1
3	0378600	Ring split Ø11x40 mm	1
4	0235955	Bolt M16x160 mm 8.8	
5	0272290	Facet plate Ø16	
6	1170282	Flange	4
7	0264090	Self-locking nut M16	16

Control for wheel cylinder

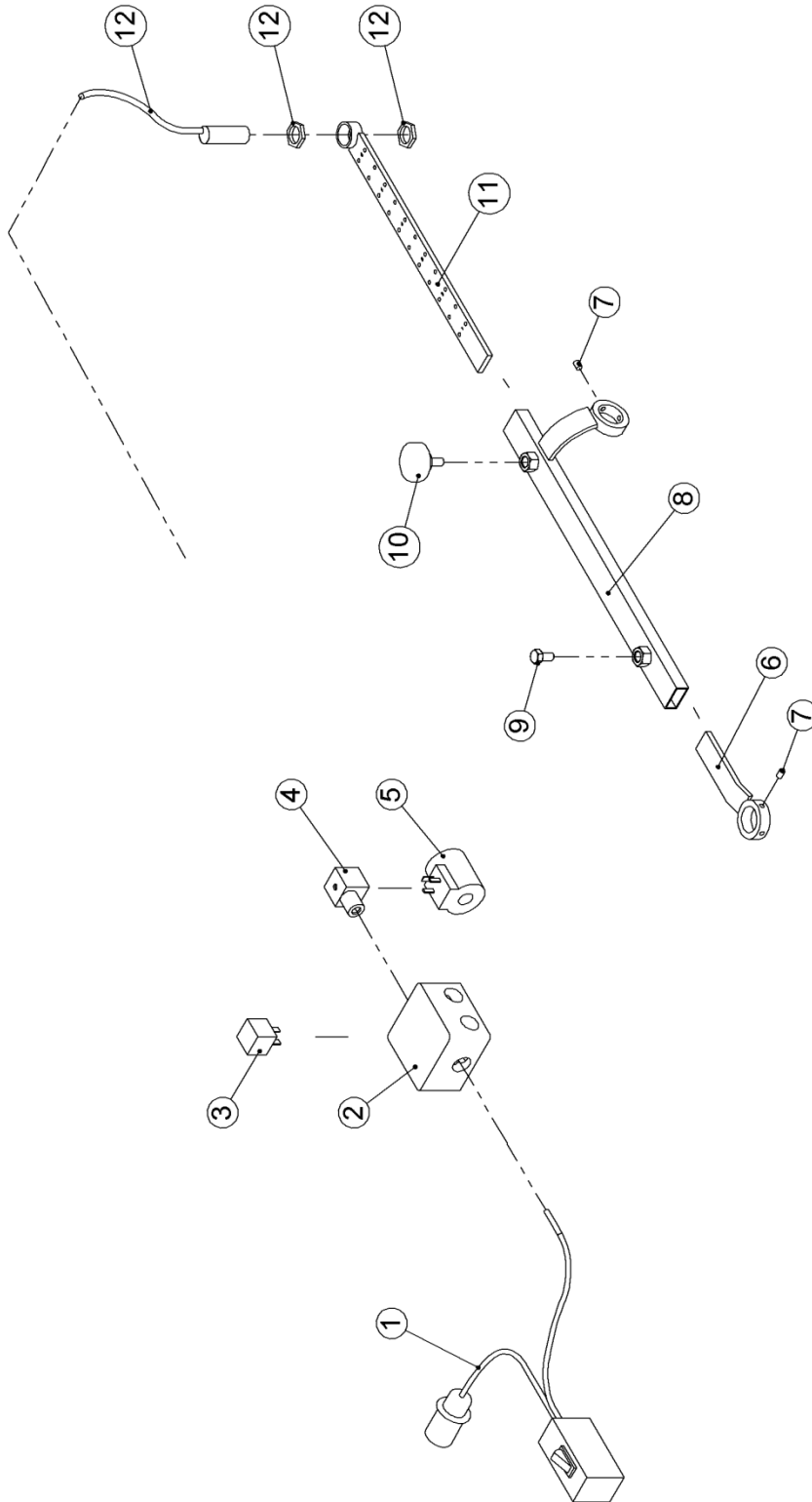

Pos.	Item no.	Designation	Number
1	0527175	Plug with switch	1
2	0520490	Plastic box	1
3	0527120	Relay (30-85-86-87)	1
4	0442766	Plug	1
5	0442764	Magnet coil	1
6	1115450	Guide bracket	1
7	0227500	Set screw M6x8 mm	2
8	1115530	Bracket for sensor	1
9	0234740	Set screw M8x16 mm 8.8	1
10	0489100	Thumbscrew M8x20 mm	1
11	1115480	Scale	1
12	0442768	Sensor with nuts	1

Light mounting

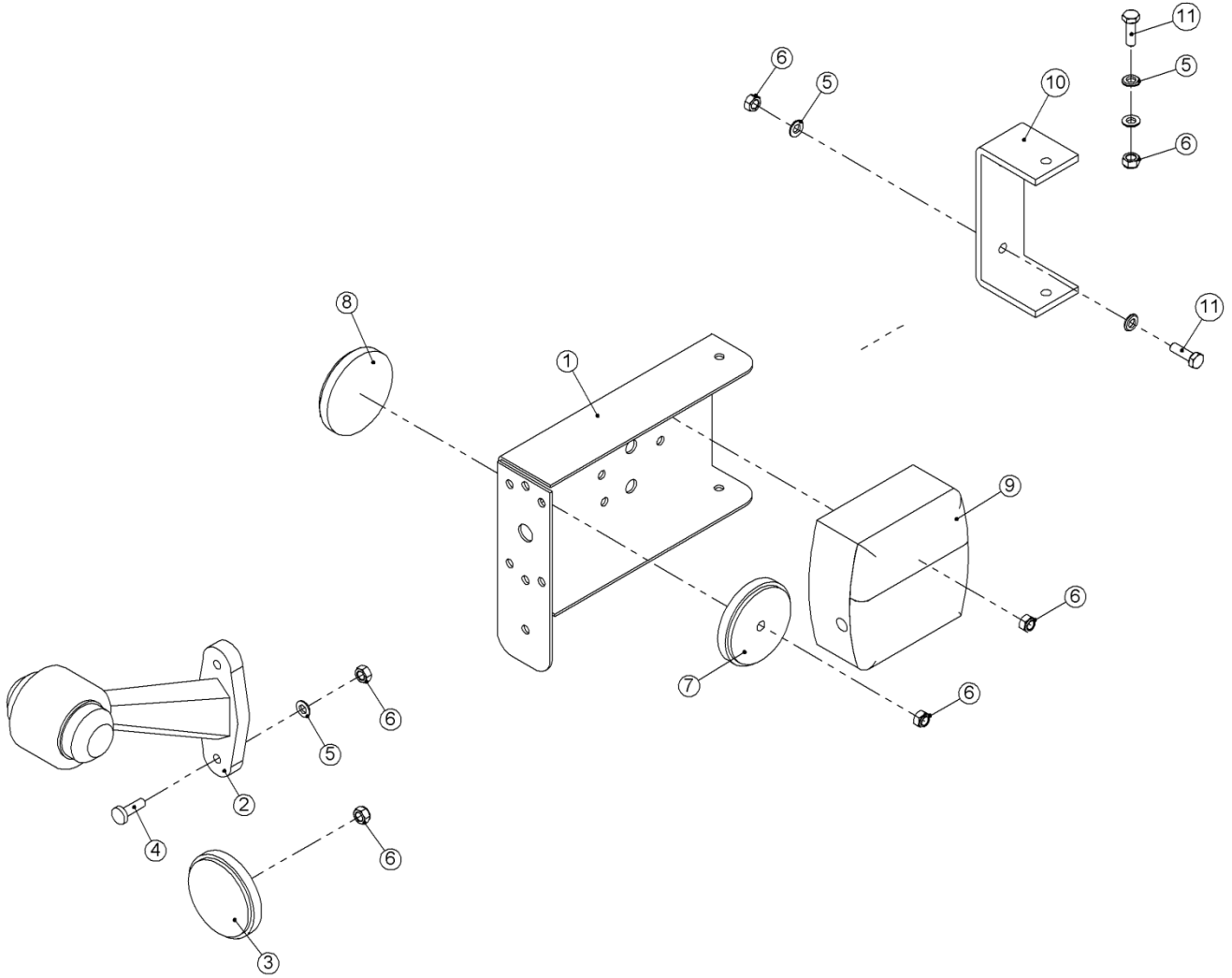

Pos.	Item no.	Designation	Number
1	1043480	Light bracket (L)	1
	1043510	Light bracket (R)	1
2	0527040	Marking lights	2
3	0656240	Reflex, yellow	2
4	0243000	Machine screw M6x20 mm 8.8	
5	0272240	Facet plate Ø6	
6	0264040	Self-locking nut M6	
7	0656260	Reflex, red	2
8	0656250	Reflex, white	2
9	0527000	Rear light, left	1
	0527010	Rear light, right	1
10	30930110	Bracket	2
11	0234330	Set screw M6x20 mm 8.8	

Hydraulics

Wings

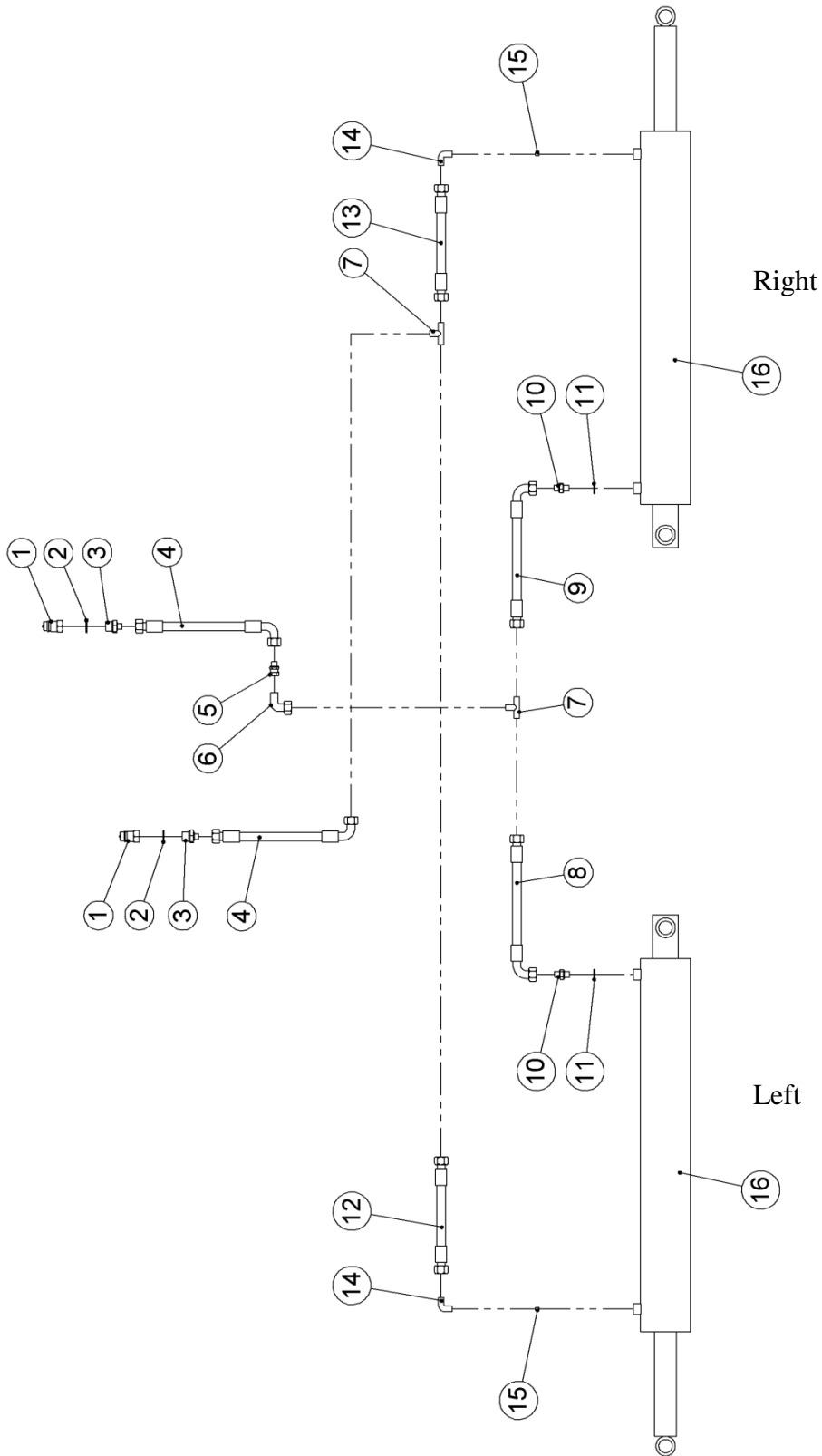

Pos.	Item no.	Designation	6, 7, 8, 9m with (3m mid- section)	9, 10m with (4m mid- section)
1	0444020	Quick coupling ½"	2	2
2	0449070	Bounded seal ½"	2	2
3	0444490	Fitting ½" - ¼"	2	2
4	0455025	Hose 6000 mm ¼"	2	2
5	0444700	Fitting ¼"	1	1
6	0446650	Fitting ¼"	1	1
7	0446510	T-nipple ¼"	2	2
8	0454230	Hose 850 mm ¼"	1	
	0454451	Hose 1500mm. ¼"		1
9	0454210	Hose 700 mm ¼"	1	
	0454310	Hose 1100mm. ¼"		1
10	0444503	Hexagon nipple ¼" with 1.5 mm drilling	2	2
11	0449050	Bounded seal ¼"	2	2
12	0454500	Hose 1600 mm ¼"		1
	0454620	Hose 2250mm. ¼"		1
13	0454450	Hose 1500mm ¼"	1	
	0454558	Hose 1850mm. ¼"		1
14	1139700	Fitting w/restrictor ¼"	2	2
15	1139710	Set screw w/restrictor M8x8 mm	2	2
16	0463105	Hydraulic cylinder Ø100/50 – length of stroke: 730 mm (6,00 og 7.00 m)	2	
	0463105	Hydraulic cylinder Ø100/50 – length of stroke: 730 mm (8.00 m) *	2	
	0463110	Hydraulic cylinder Ø135/50 – length of stroke: 730 mm (9.00 m w/3.0 m middle section)	2	
	0463110	Hydraulic cylinder Ø135/50 – length of stroke: 730 mm (9.00 m w/4.0 m middle section)		2
	0463110	Hydraulic cylinder Ø135/50 – length of stroke: 730 mm (10.00 m)		2

* Exception: Euro-Tiller with a mounted roller is equipped with 2 pcs. Ø135/50 hydraulic cylinders (item no. 0463110).

Wheel (with 3m middle frame)

Right

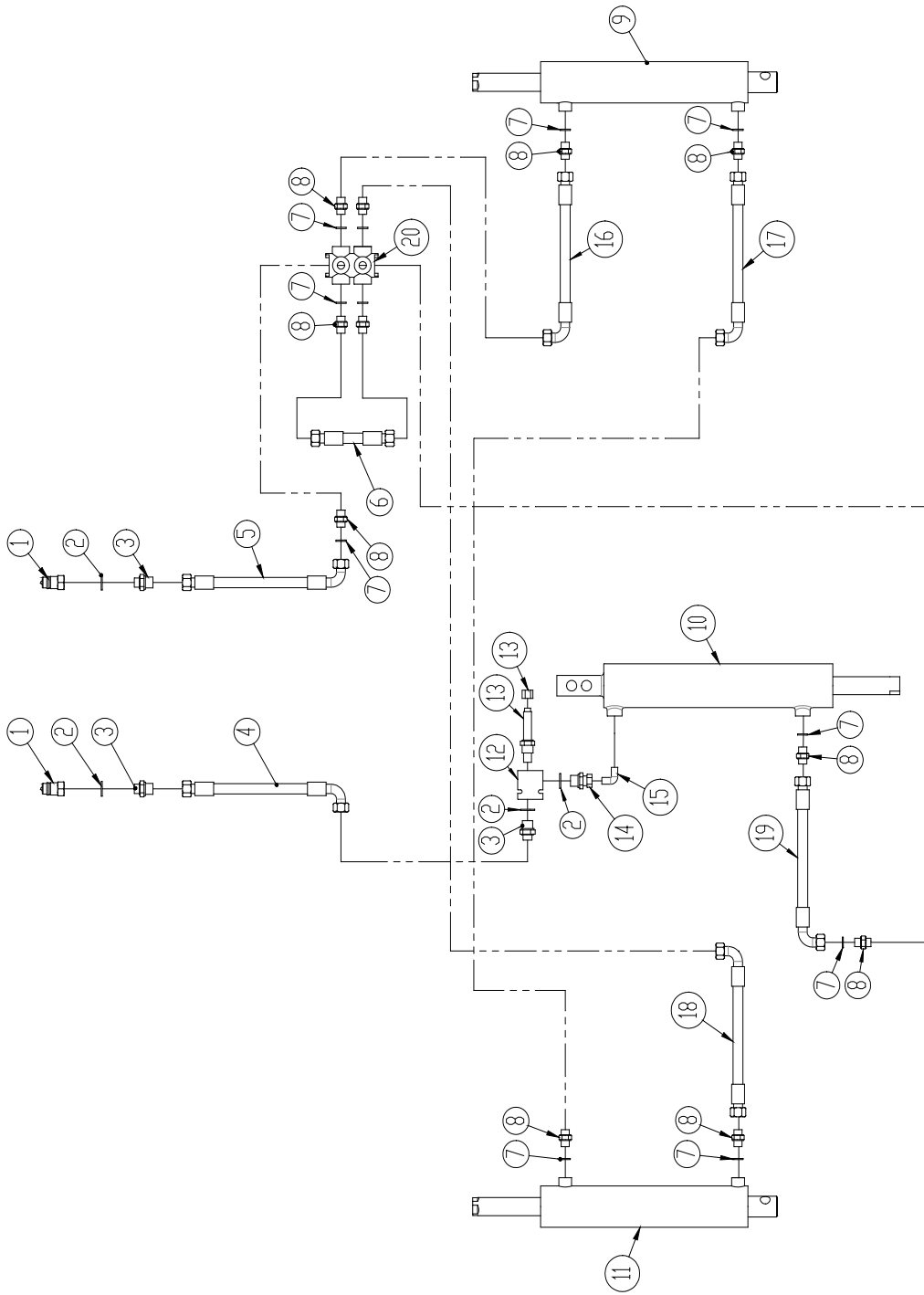

Left

Pos.	Item no.	Designation	Number 6m	Number 7,8,9m
1	0444020	Quick coupling 1/2"	2	2
2	0449070	Bounded seal 1/2"	4	4
3	0444550	Hexagon nipple 1/2" - 3/8"	3	3
4	0454991	Hydr. hose 5000 mm 3/8" k	1	1
5	0454965	Hydr. hose 4070mm. 3/8"	1	1
6	0454161	Hydr. hose 400mm. 3/8"	1	1
7	0449060	Bounded seal 3/8"	9	9
8	0444530	Hexagon nipple 3/8"	9	9
9	0468501	Hydraulic cylinder Ø70/60 – length of stroke: Ø35x300 mm (for machine No 28966)	1	1
	0468502	Hydraulic cylinder Ø70/60 – length of stroke: Ø35x284 mm (from machine No 28967)	1	1
10	0468600	Hydraulic cylinder Ø85/75 – length of stroke: Ø35x328 mm (for machine No 28966)	1	1
	0468602	Hydraulic cylinder Ø85/75 – length of stroke: Ø35x312 mm (from machine No 28967)	1	1
11	0468701	Hydraulic cylinder Ø80/70 – length of stroke: Ø35x295 mm (for machine No 28966)	1	1
	0468702	Hydraulic cylinder Ø80/70 – length of stroke: Ø35x279 mm (from machine No 28967)	1	1
12	0442763	Valve block	1	1
13	0442762	Cartridge valve with nut	1	1
14	0444690	Fitting 1/2" - 3/8"	1	1
15	0446120	Fitting 3/8"	1	1
16	0454979	Hydr. hose 4850mm. 3/8"	1	
	0454993	Hydr. hose 5300mm. 3/8"		1
17	0455170	Hydr. hose 8000mm. 3/8"	1	
	0455252	Hydr. hose 8600mm. 3/8"		1
18	0454992	Hydr. hose 5300mm. 3/8"	1	
	0455023	Hydr. hose 5900mm. 3/8"		1
19	0454579	Hydr. hose 2000mm. 3/8"	1	1
20	0442750	Valve	1	1

Wheel (with 4m middle frame)

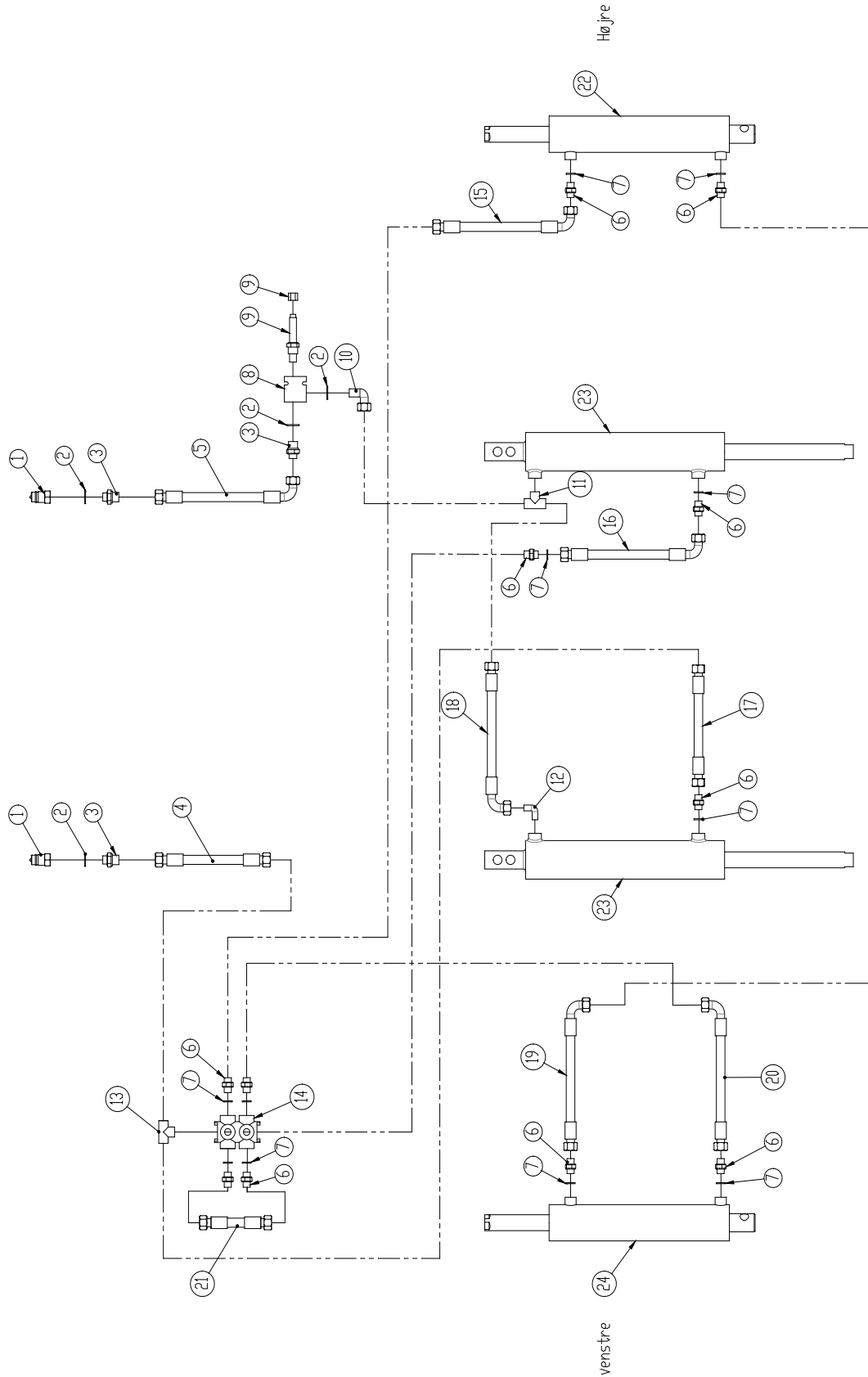

Pos.	Item no.	Designation	Number
1	0444020	Quick coupling 1/2"	2
2	0449070	Bounded seal 1/2"	4
3	0444550	Hexagon nipple 1/2" - 3/8"	3
4	0454965	Hydr. hose 4070mm. 3/8"	1
5	0454991	Hydr. hose 5000 mm 3/8"	1
6	0444530	Hexagon nipple 3/8"	11
7	0449060	Bounded seal 3/8"	11
8	0442763	Valve block	1
9	0442762	Cartridge valve with nut	1
10	0446660	Fitting 3/8"	1
11	0446530	T-nipple 3/8	1
12	0446120	Fitting 3/8"	2
13	0446520	T-nipple 3/8	1
14	0442750	Valve	1
15	0455019	Hydr. hose 5700mm. 3/8"	1
16	0454579	Hydr. hose 2000mm. 3/8"	1
17	0454522	Hydr. hose 1600mm. 3/8"	1
18	0454162	Hydr. hose 400 mm 3/8"	1
19	0455390	Hydr. hose 9600 mm 3/8"	1
20	0455029	Hydr. hose 6300mm. 3/8"	1
21	0454161	Hydr. hose 400mm. 3/8"	1
22	0468501	Hydraulic cylinder Ø70/60 – length of stroke: Ø35x300 mm (for machine Njo 28966)	1
	0468502	Hydraulic cylinder Ø70/60 – length of stroke: Ø35x284 mm (from machine No 28967)	1
23	0468600	Hydraulic cylinder Ø85/75 – length of stroke: Ø35x328 mm (for machine No 28966)	2
	0468602	Hydraulic cylinder Ø85/75 – length of stroke: Ø35x312 mm (from machine No 28967)	2
24	0468701	Hydraulic cylinder Ø80/70 – length of stroke: Ø35x295 mm (for machine No 28966)	1
	0468702	Hydraulic cylinder Ø80/70 – length of stroke: Ø35x279 mm (from machine No 28967)	1

Spring-Board

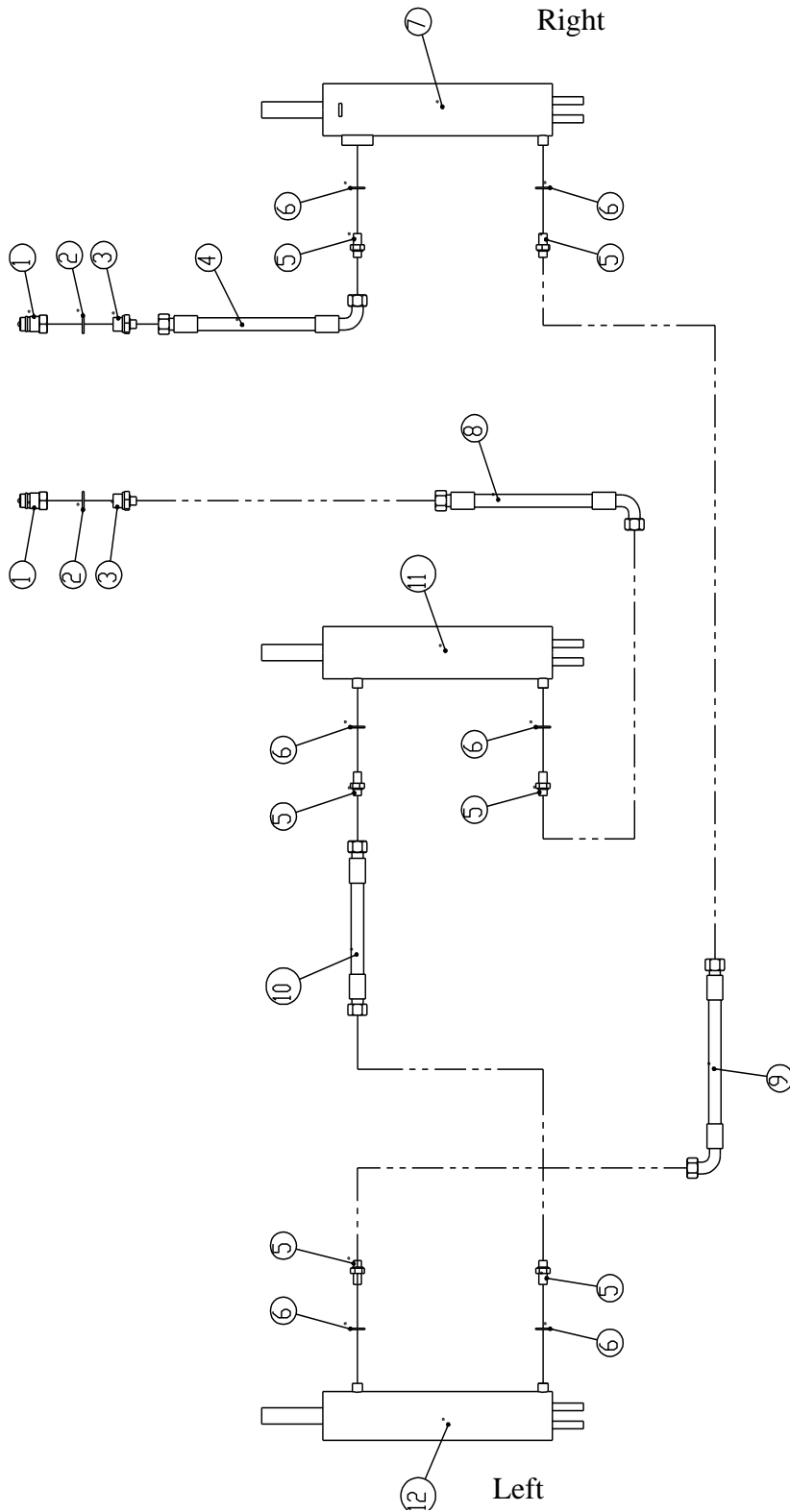

Pos.	Item no.	Designation	6m	7,8,9m	9,10m
1	0444020	Quick coupling 1/2"	2	2	2
2	0449070	Bounded seal 1/2"	2	2	2
3	0444490	Hexagon nipple 1/2" - 1/4"	2	2	2
4	0455093	Hose 7300mm. 1/4"	1		
	0455100	Hose 7500mm. 1/4"		1	
	0455160	Hose 8000mm. 1/4"			1
5	0444501	Hexagon nipple 1/4"	6	6	6
6	0449050	Bounded seal 1/4"	6	6	6
7	0468800	Hydraulic cylinder Ø70/60 length of stroke: Ø25x295 mm	1	1	1
8	0455025	Hose 6000mm. 1/4"	1	1	
	0455028	Hose 6200mm. 1/4"			1
9	0454978	Hose 4800mm. 1/4"	1		
	0454995	Hose 5300mm. 1/4"		1	
	0455025	Hose 6000mm. 1/4"			1
10	0454560	Hose 850mm. 1/4"	1		
	0454590	Hose 2000mm. 1/4"		1	
	0454650	Hose 2350mm. 1/4"			1
11	0468900	Hydraulic cylinder Ø80/70 length of stroke: Ø25x260 mm	1	1	1
12	0469000	Hydraulic cylinder Ø75/65 length of stroke: Ø25x260 mm	1	1	1

Quick coupling, facing backwards – clevis rear

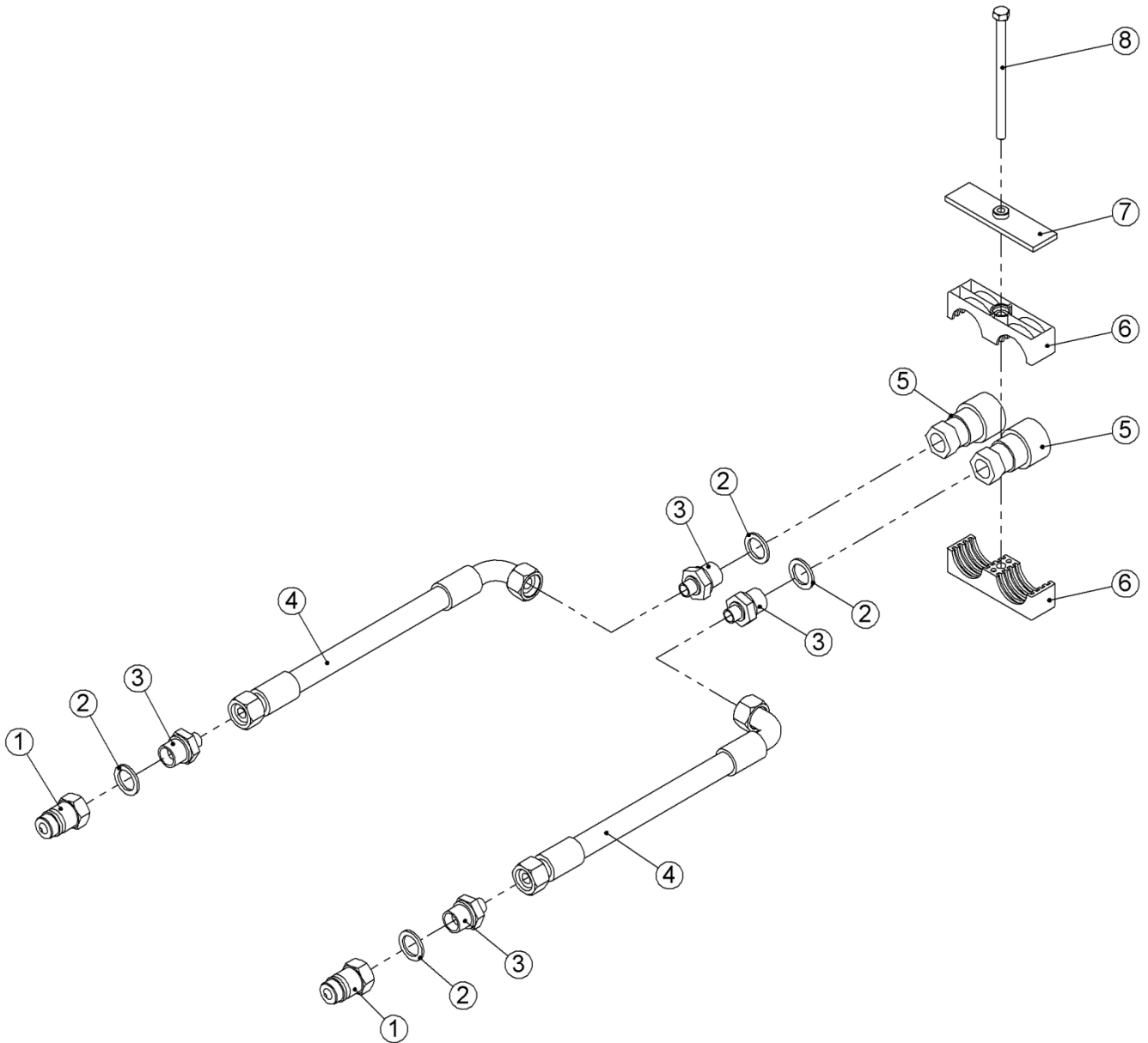

Pos.	Item no.	Designation	Number
1	0444020	Quick coupling 1/2" – male	4
2	0449070	Bounded seal 1/2"	8
3	0444490	Hexagon nipple 1/2" - 1/4"	8
4	0455100	Hose 7500 mm 1/4"	4
5	0444030	Quick coupling 1/2" – female	4
6	0449750	Tube-support double Ø38	4
7	690210220	Top plate	1
8	0235000	Bolt M8x130 mm 8.8	1

El. depth stop

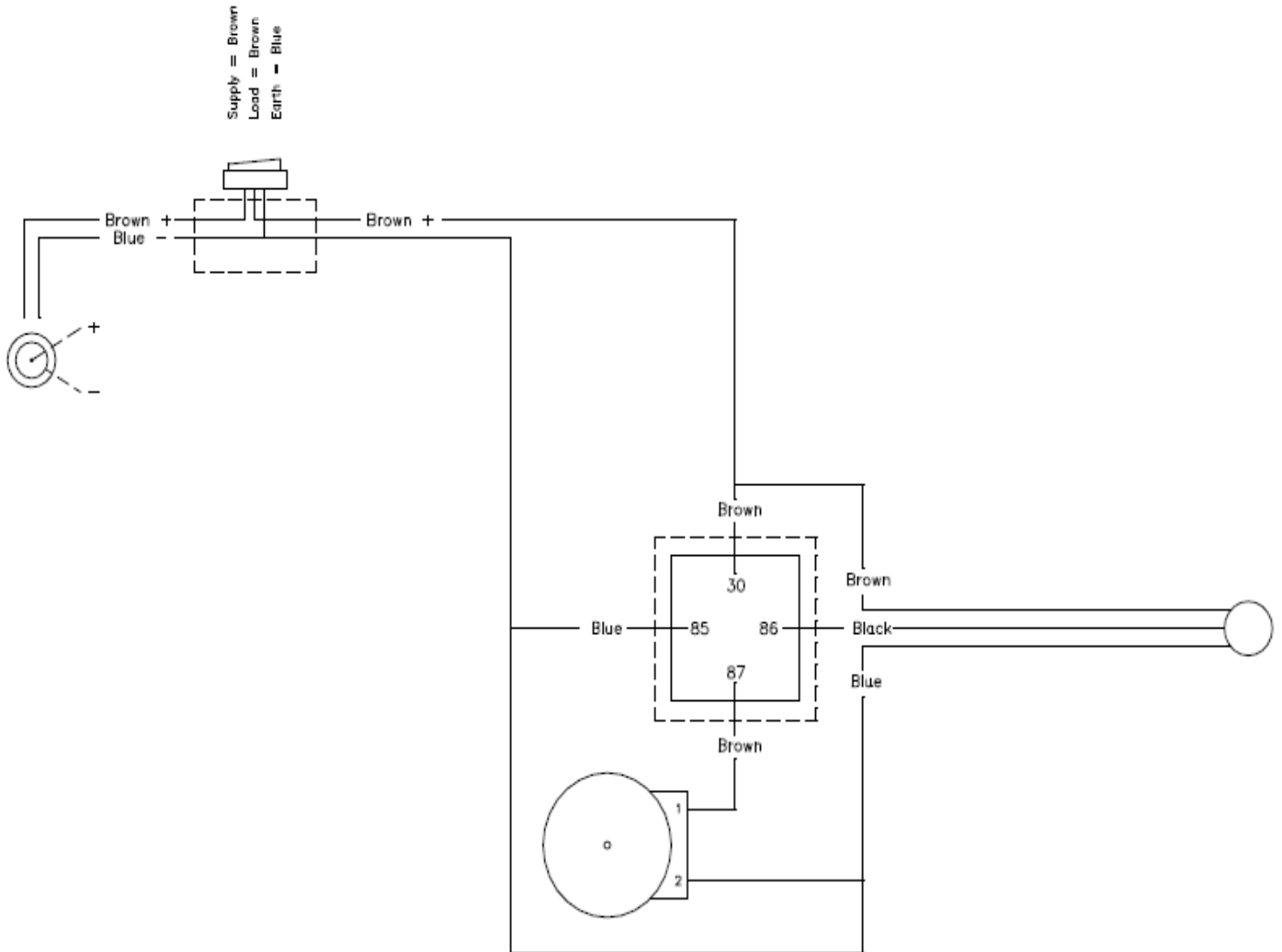

Notes

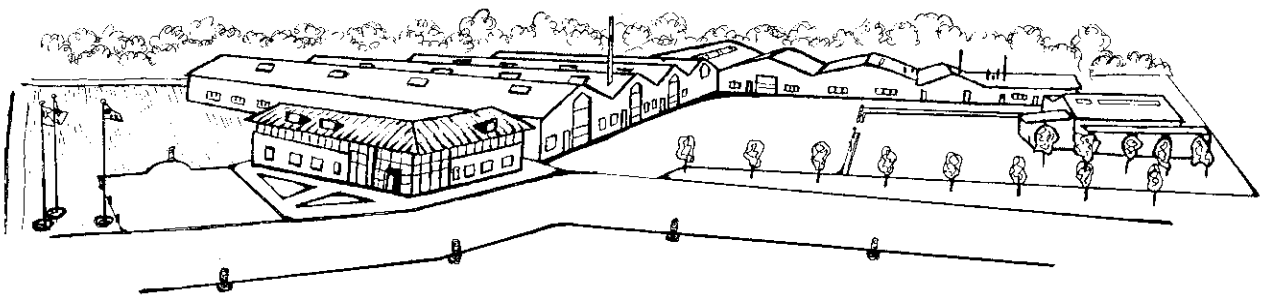

The design is subject to modification without notice.