



**HE-VA**  
**DOUBLET**

# Euro-Seeder



Reservedelsliste  
Spare parts list  
Ersatzteilliste  
Liste de pièces de rechange

Ørding DK-7990 Ø. Assels Tlf.: 97766100 Telefax.: 97766130

E-mail : [info@hevadoublet.com](mailto:info@hevadoublet.com) [www.hevadoublet.com](http://www.hevadoublet.com)

© Copyright 2003 Heva-doublet APS

## Indholdsfortegnelse

Skiveskær.....	4
Langfinger efterharve.....	6
Harveramme.....	8
Valsler og ramme.....	10
Såhjul og ophæng.....	12
Trappe og platform.....	14
Såkasse.....	16
Hjulvogn.....	18
Trækstang.....	20
Forharve.....	22
Tankramme med beslag.....	24
Doceringsenhed.....	26
Cellehjul.....	28
Fordeler.....	30
Kørespør.....	32
FS4 og sensorer.....	34
Halvsidelukning.....	36
Vario blæser og pumpe.....	38
Markører.....	40
Injektør, sikkerhedslås og holdebeslag for variopumpe.....	42
Hydraulik for vognløft og løft af såhjul.....	44
Hydraulik for planke forharve.....	46
Lys.....	48

## Table of contents

Coulter.....	4
Long-finger-harrow.....	6
Harrow frame.....	8
Rollers and frame.....	10
Seed wheel.....	12
Staircase and platform.....	14
Hopper.....	16
Wheel frame.....	18
Drawbar.....	20
Front harrow.....	22
Frame for hopper.....	24
Cell wheel.....	26
Cell wheel.....	28
Dividing head.....	30
Tramline.....	32
FS4 and sensors.....	34
Closing device for half side.....	36
Vario blower and pump.....	38
Markers.....	40
Injector, security lock and bracket for oil pump.....	42
Hydraulic for transport wheels and seed wheel.....	44
Hydraulic for front harrow.....	46
Light.....	48

## Inhaltverzeichnis

Säschar.....	4
Zustreichegge.....	6
Eggenrahmen.....	8
Walzen und Walzerahmen.....	10
Drillrad.....	12
Treppe und Plattenrost.....	14
Saatkasten.....	16
Radstativ.....	18
Zugstange.....	20
Egge, vorne.....	22
Rahmen für saatkasten.....	24
Dosiereinheit.....	26
Zellenrad.....	28
Verteiler.....	30
Fahrgassenschalt.....	32
FS4 und Sensoren.....	34
Halbseitenabschaltung.....	36
Vario antrieb.....	38
Spuranzeiger.....	40
Injektor, Sicherheitsbeschlag, Beschlag für Ölpumpe.....	42
Hydraulik für radstativ und Drillrad.....	44
Hydraulik für Egge, vorn.....	46
Licht.....	48

## Table des matieres

Soc.....	4
Herse arriere a dents.....	6
Châsis de herse.....	8
Rouleau et châsis de rouleau.....	10
Roue.....	12
Passerelle.....	14
Tremie.....	16
Suspension des roues.....	18
Flèche.....	20
Herse, devant.....	22
Châsis de tremie.....	24
Doseur.....	26
Roue cellules.....	28
Tete diviseur.....	30
Jalonnage plus.....	32
FS4 et sensors.....	34
Fermeture d'une moitié de la distribution.....	36
Animation vario.....	38
Marquer.....	40
Injecteur, garniture pour vario.....	42
Hydraulique pour suspension des roues.....	44
Hydraulique pour herse devant.....	46
Phare.....	48

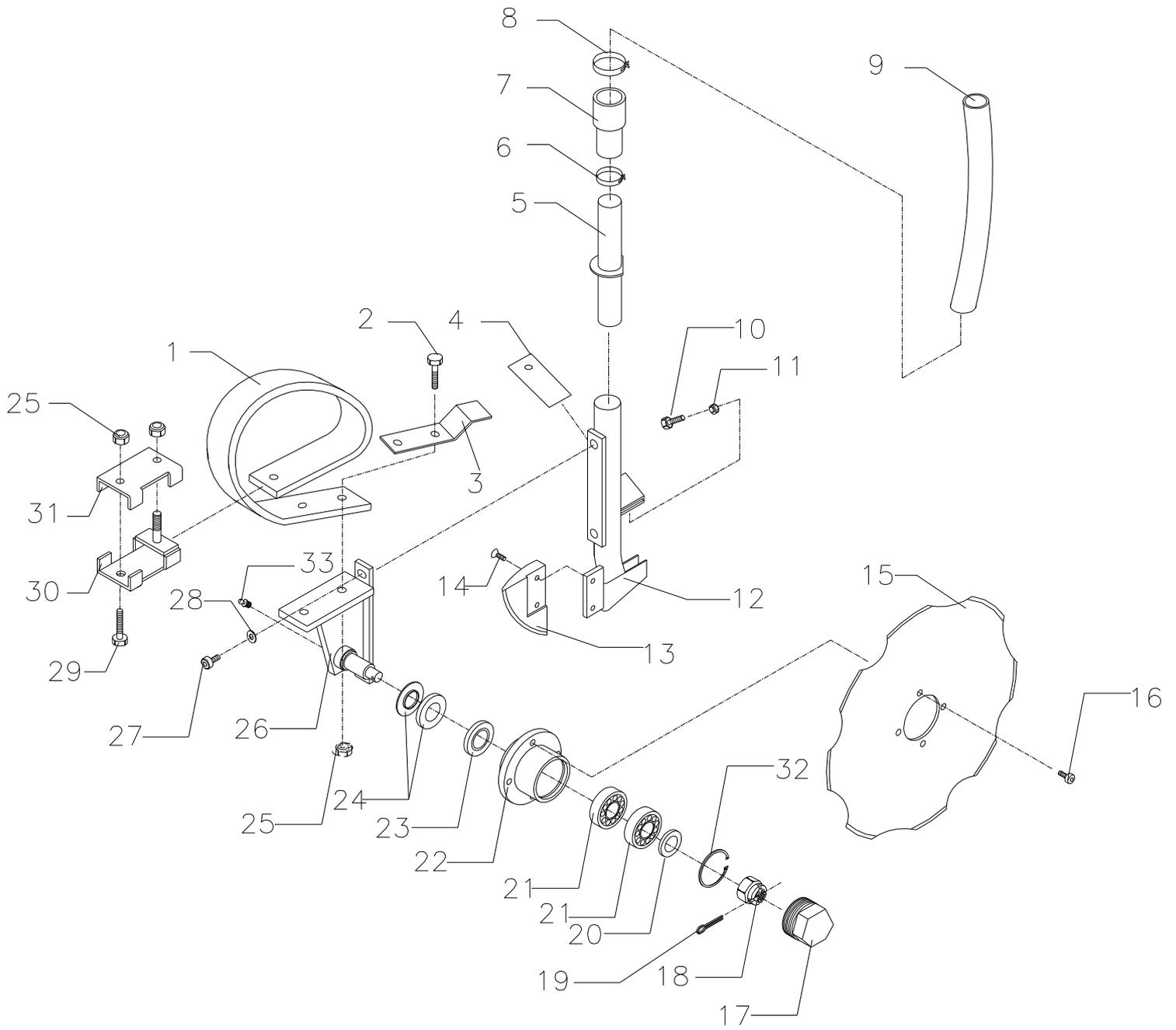



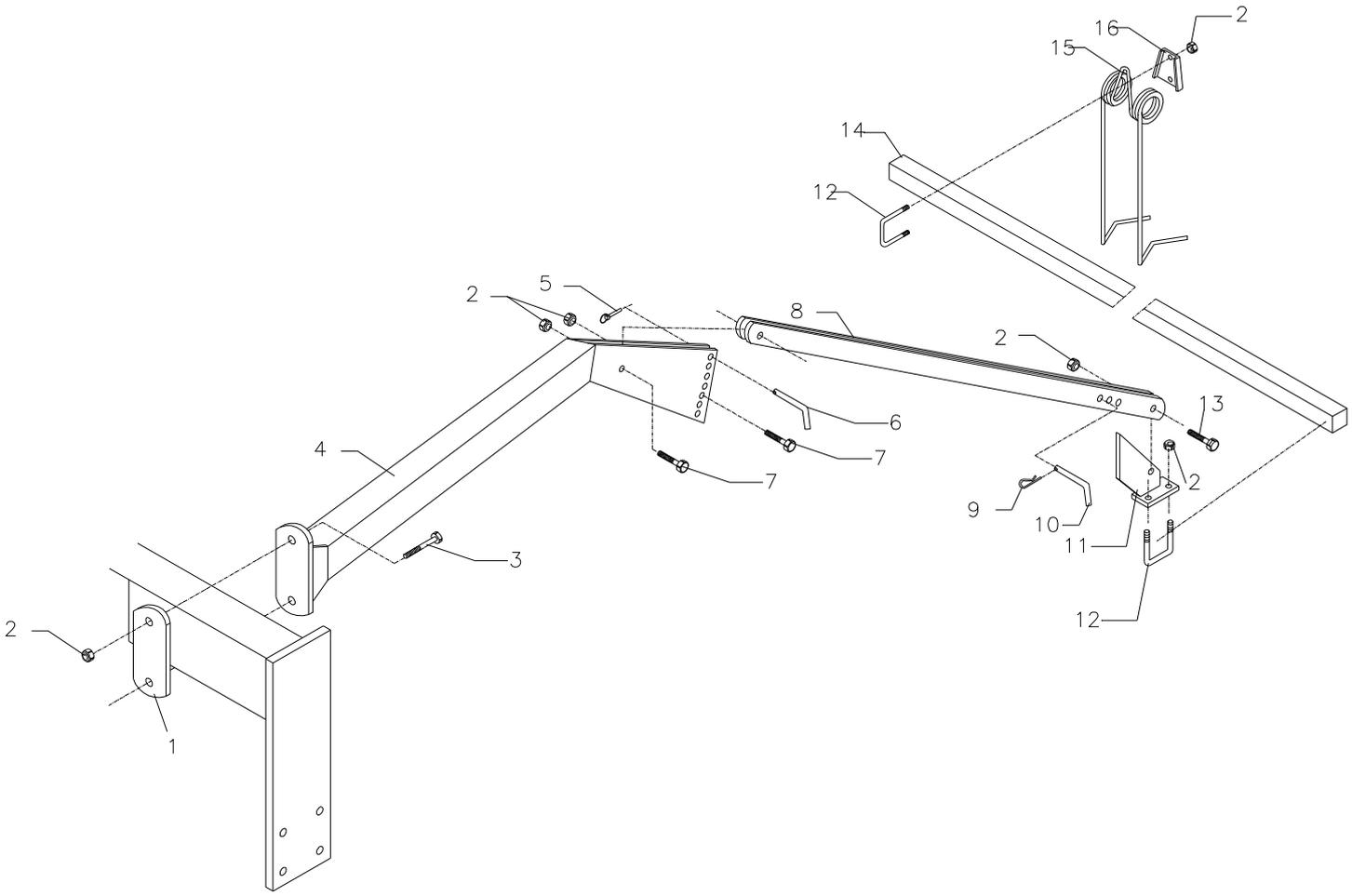



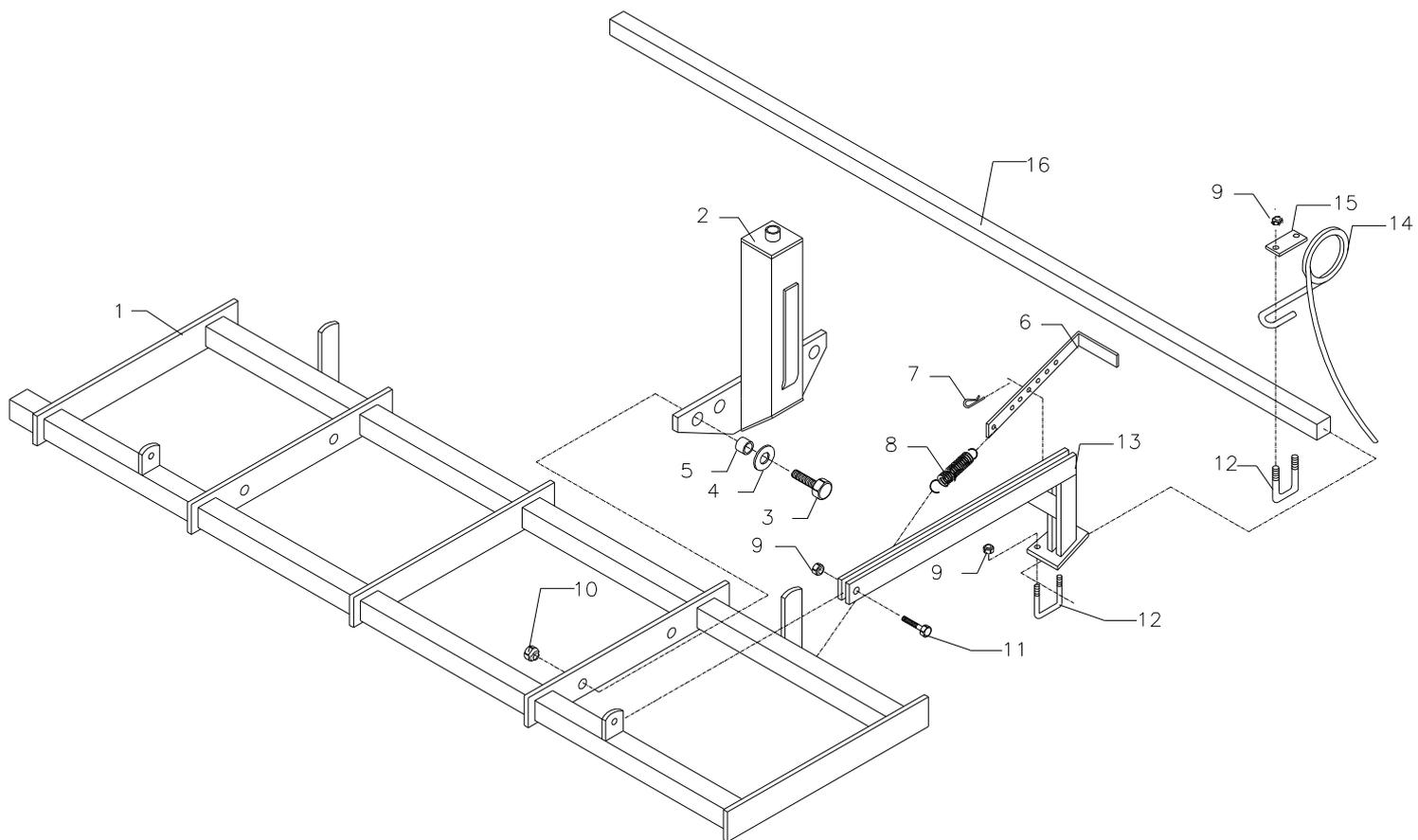



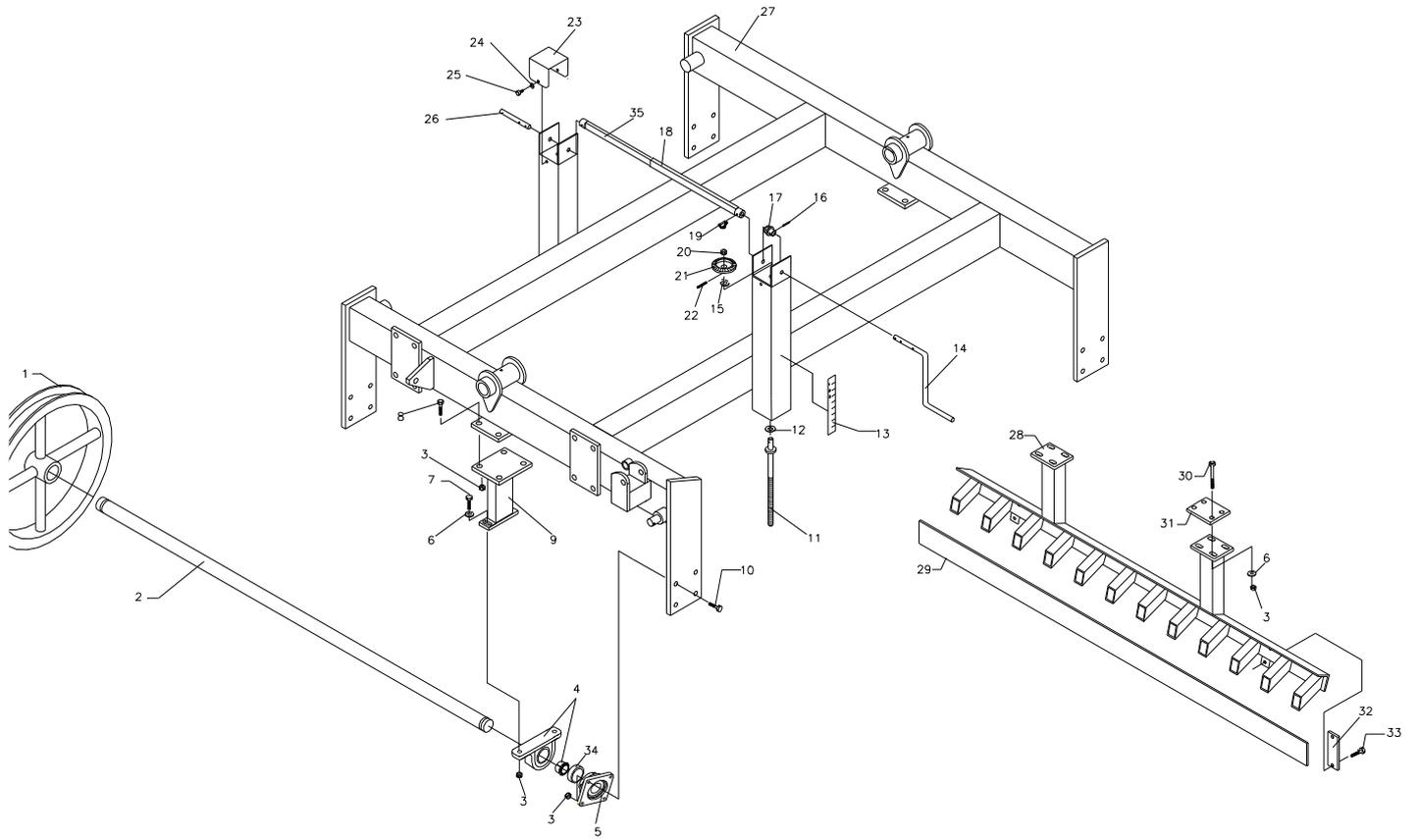



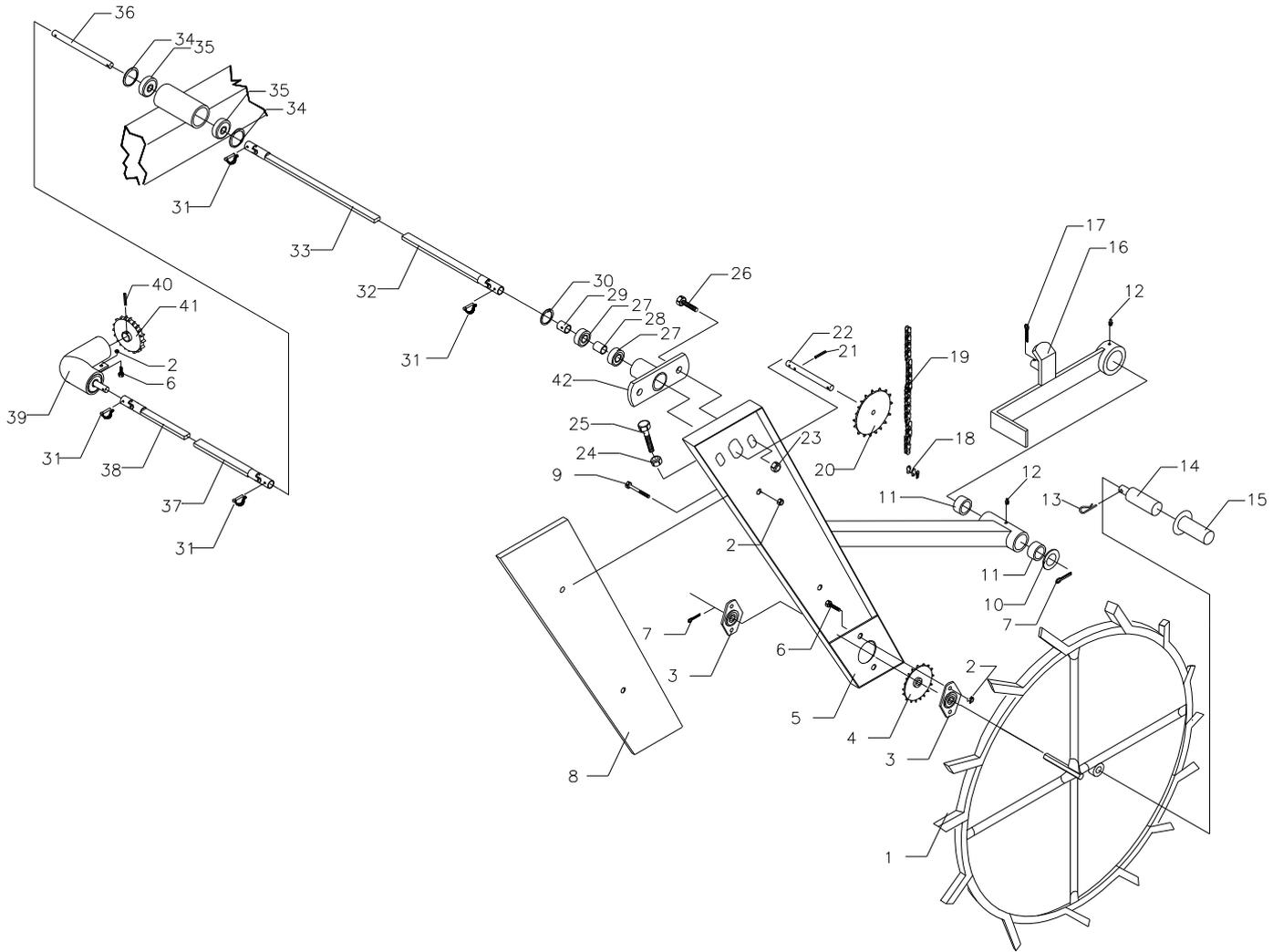



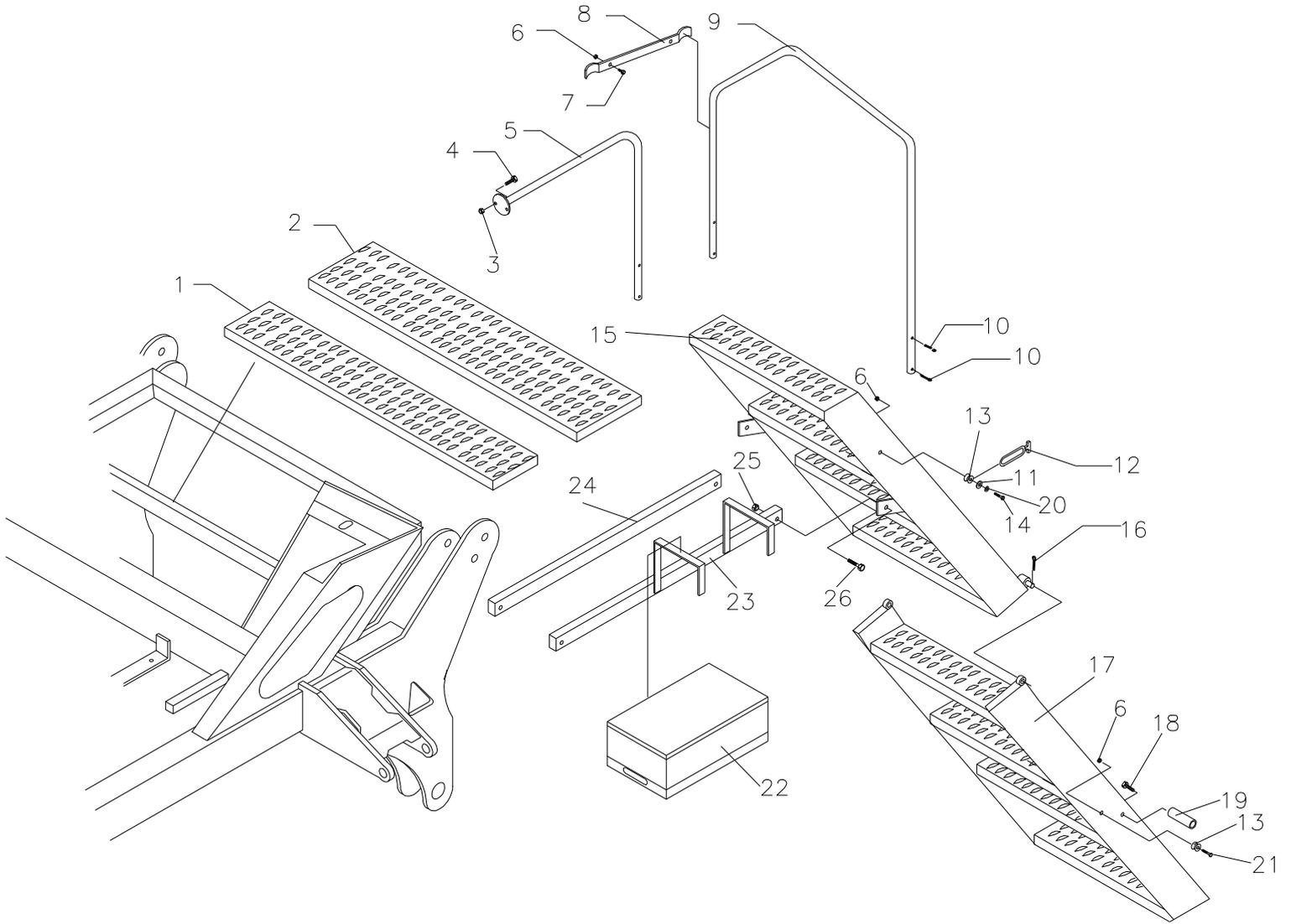



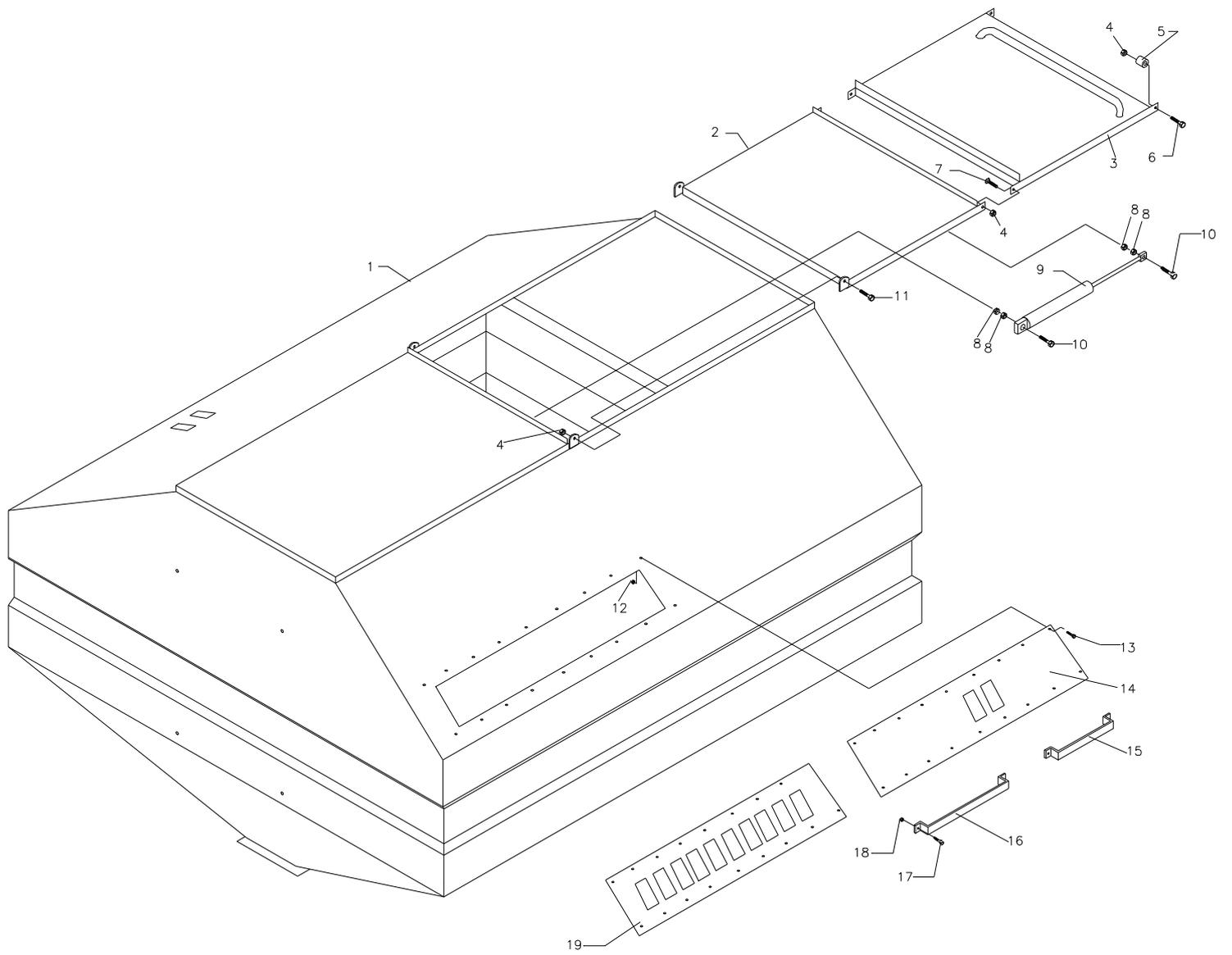



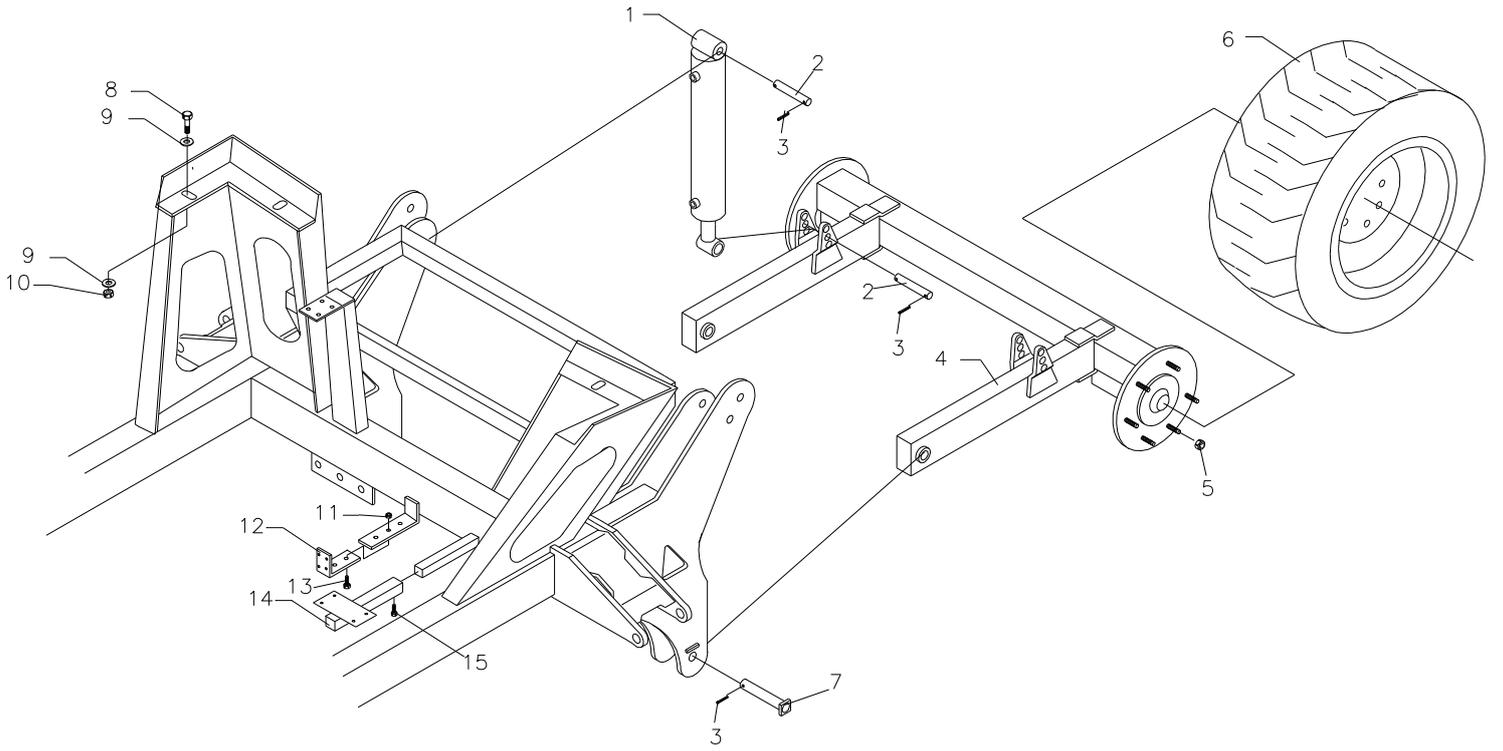



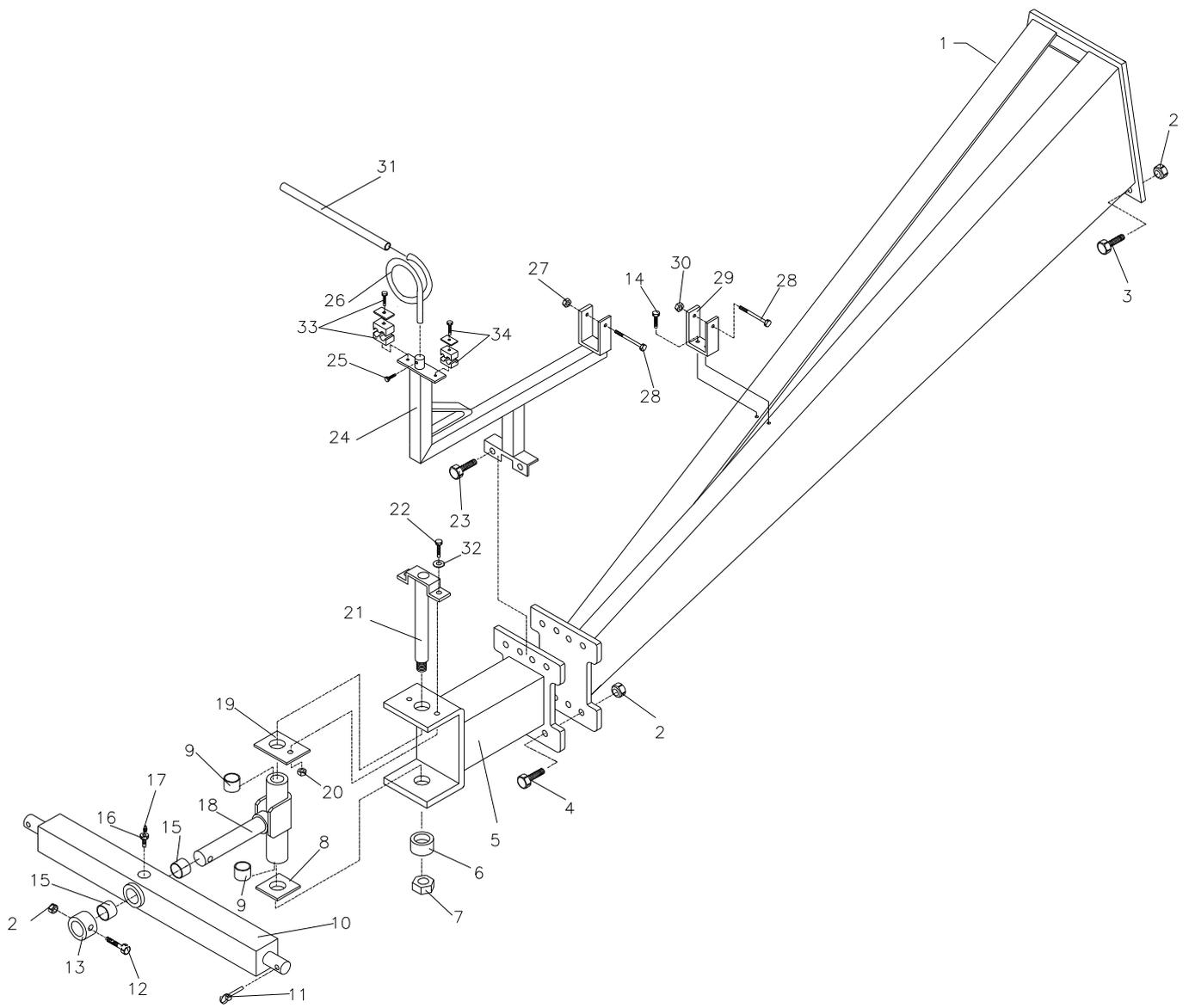



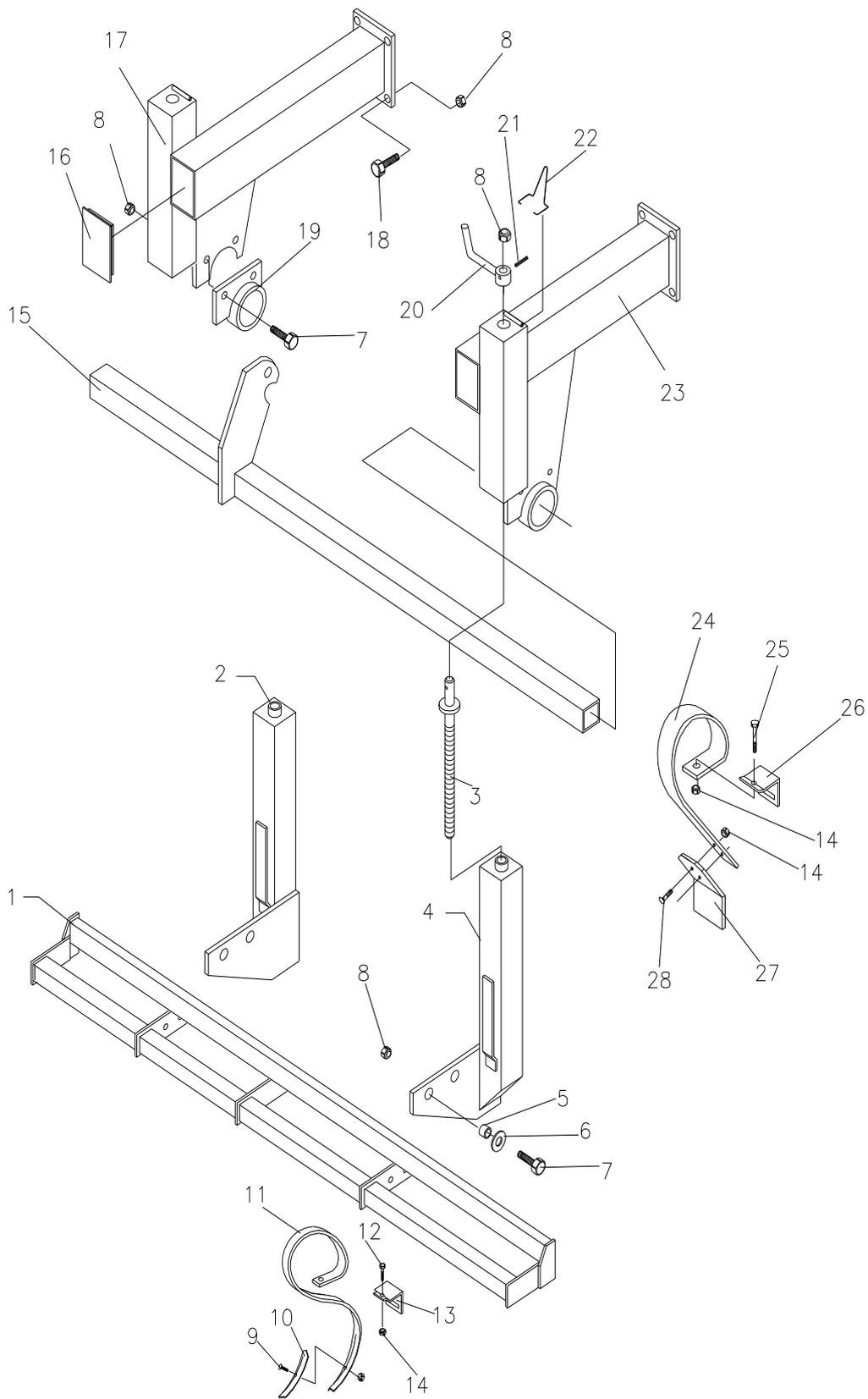



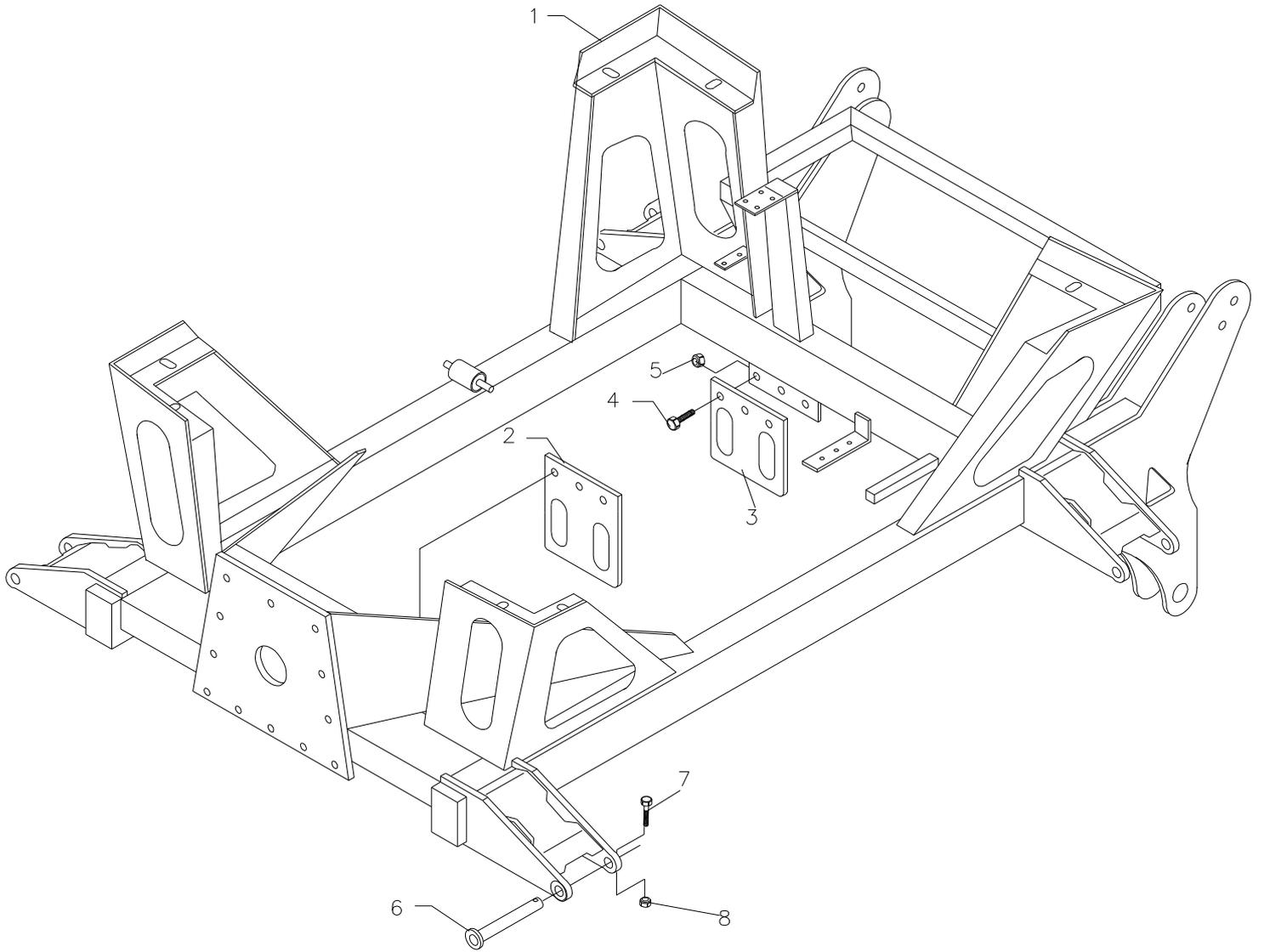



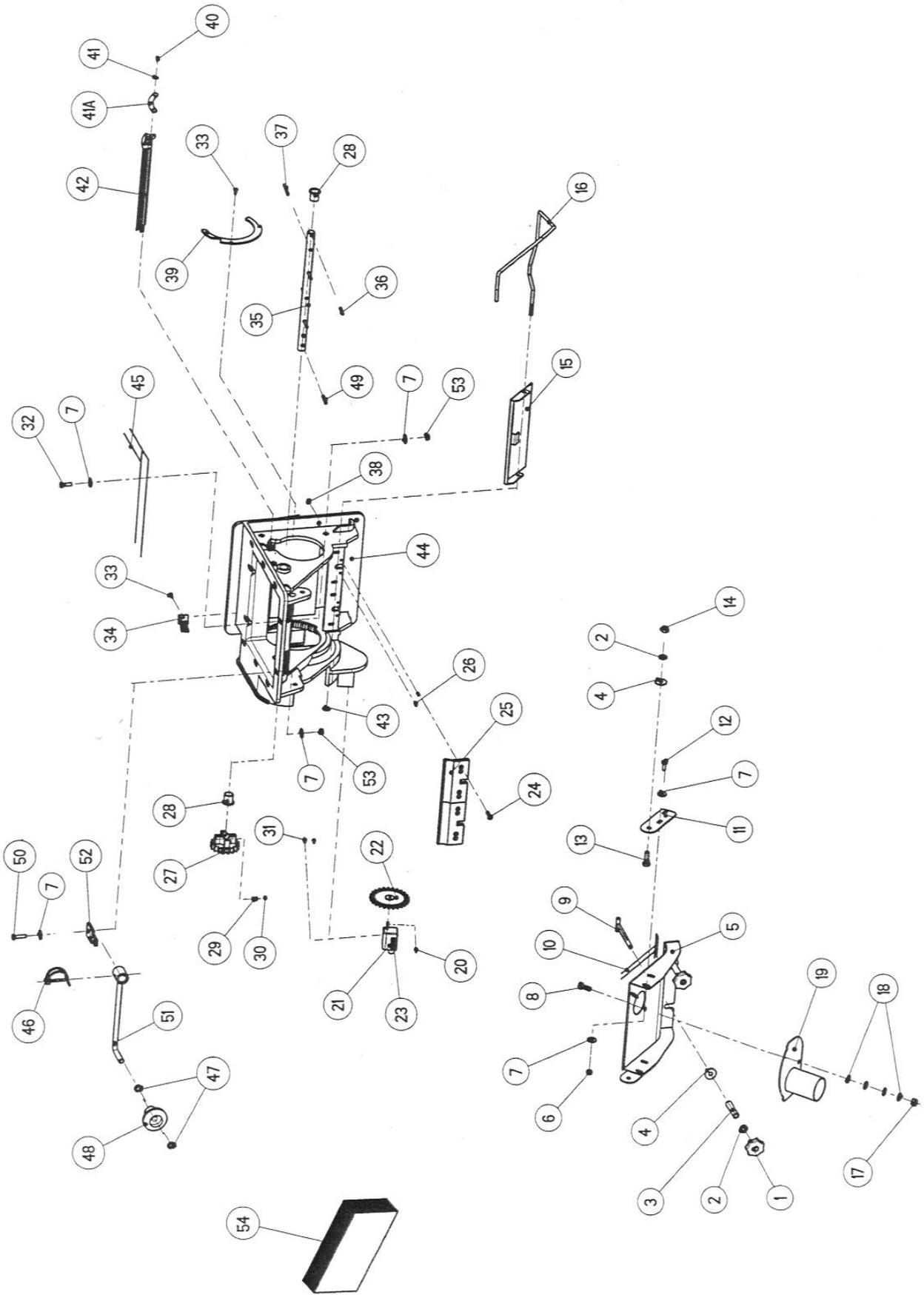



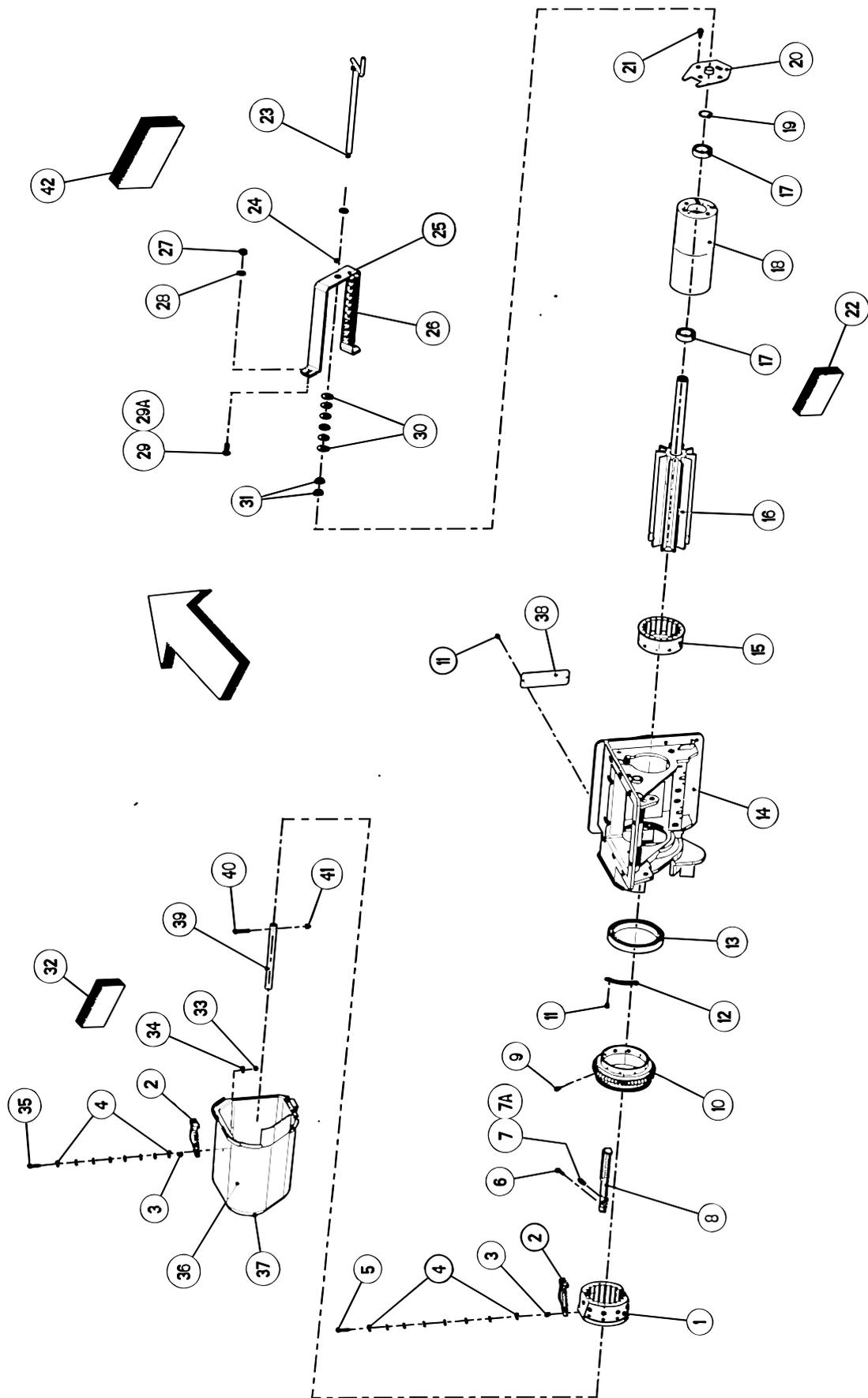



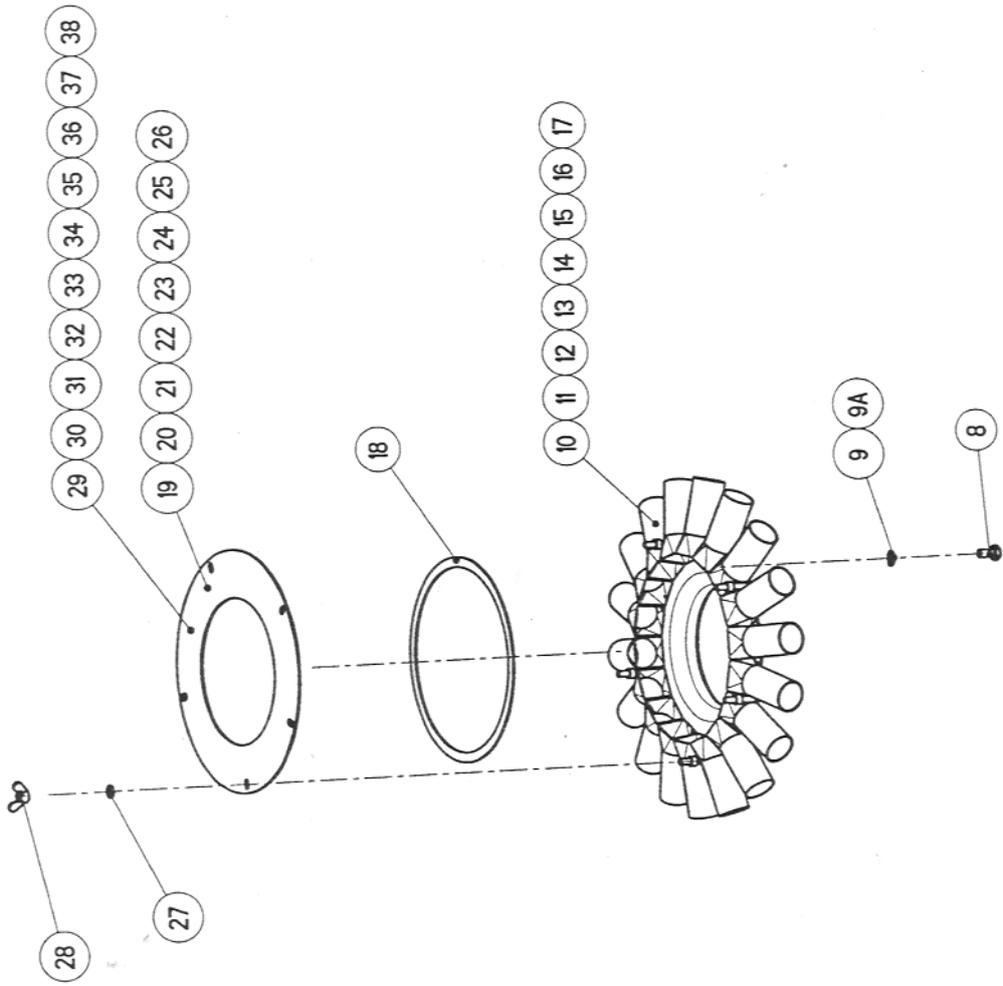



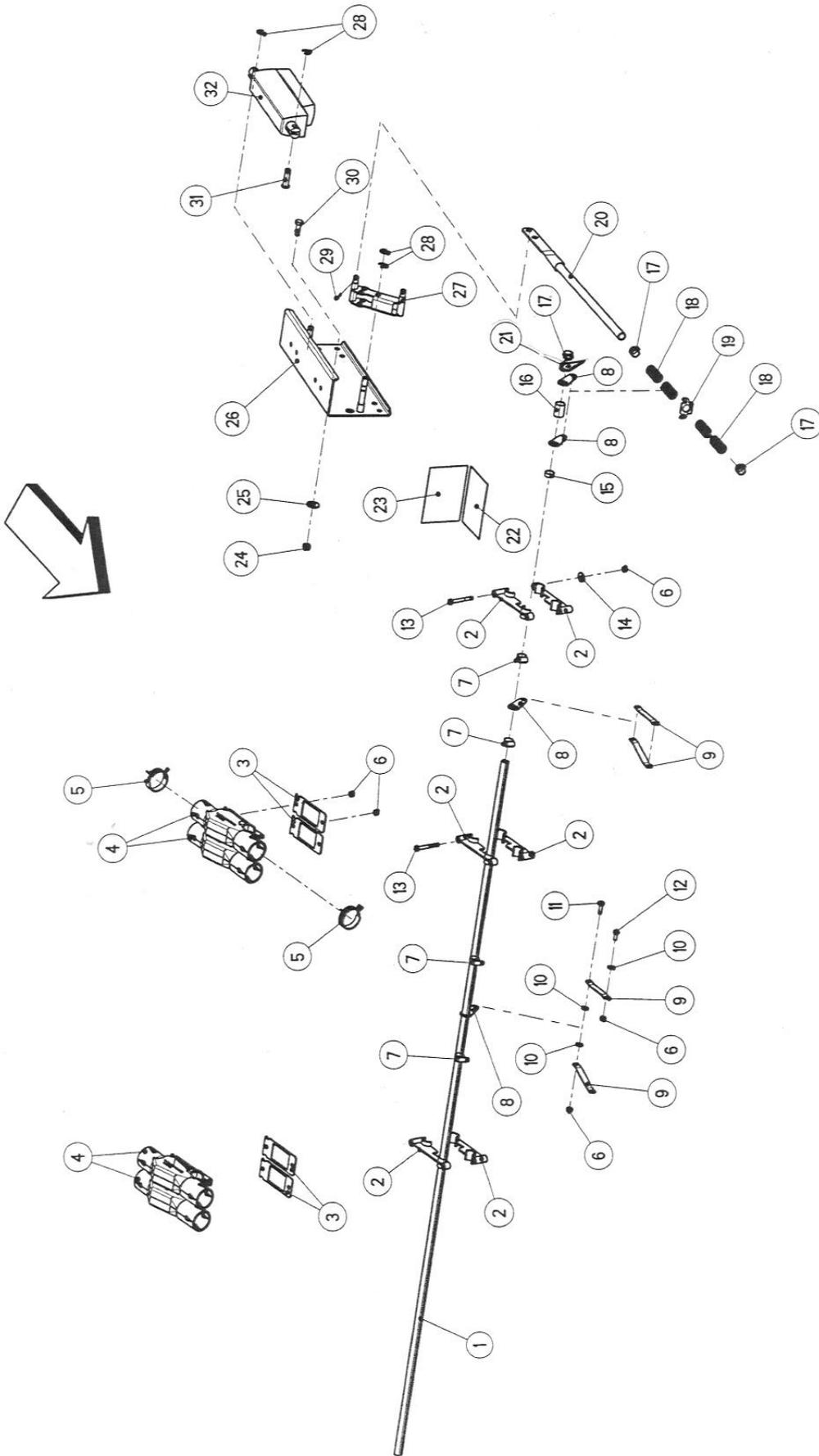



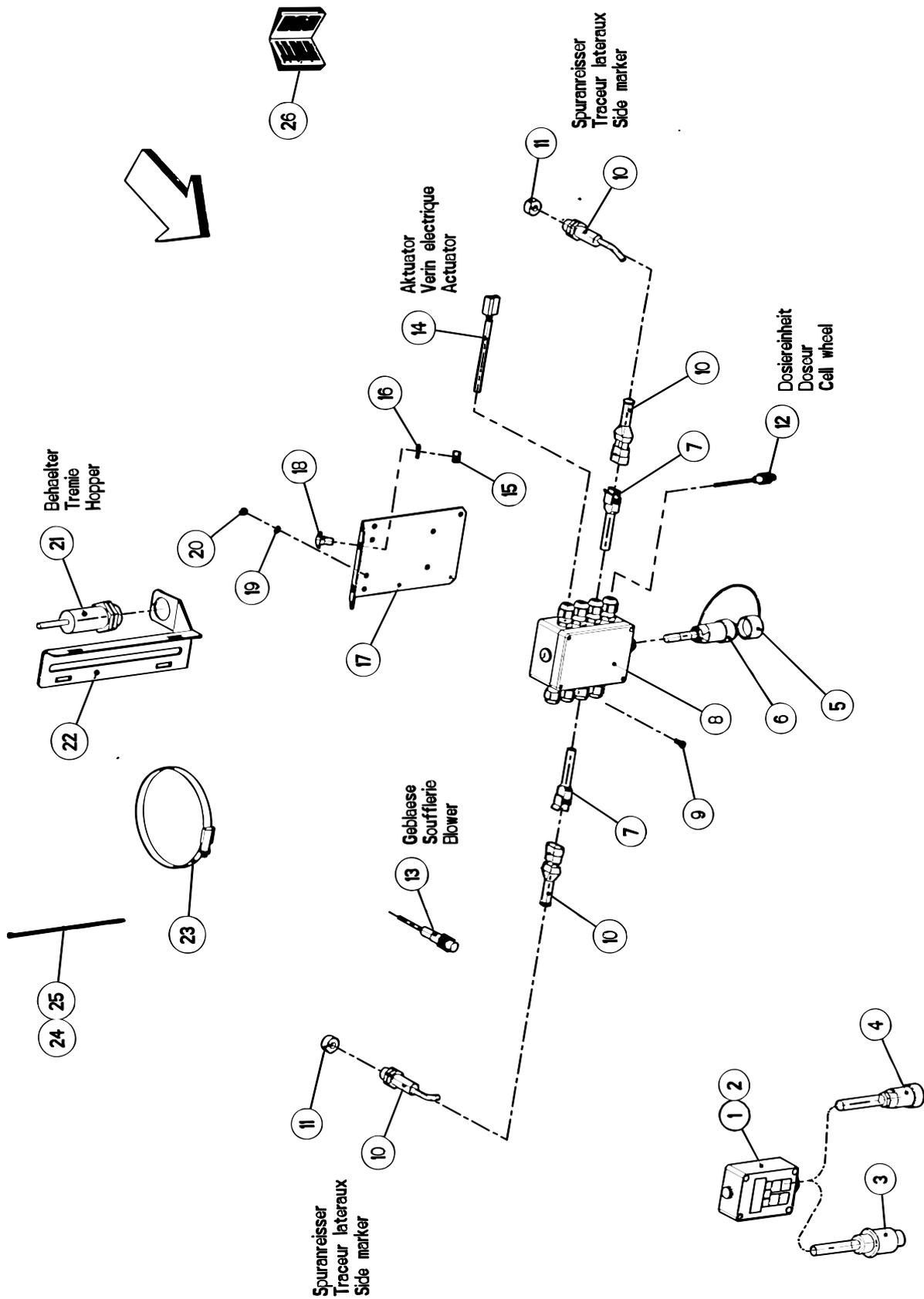



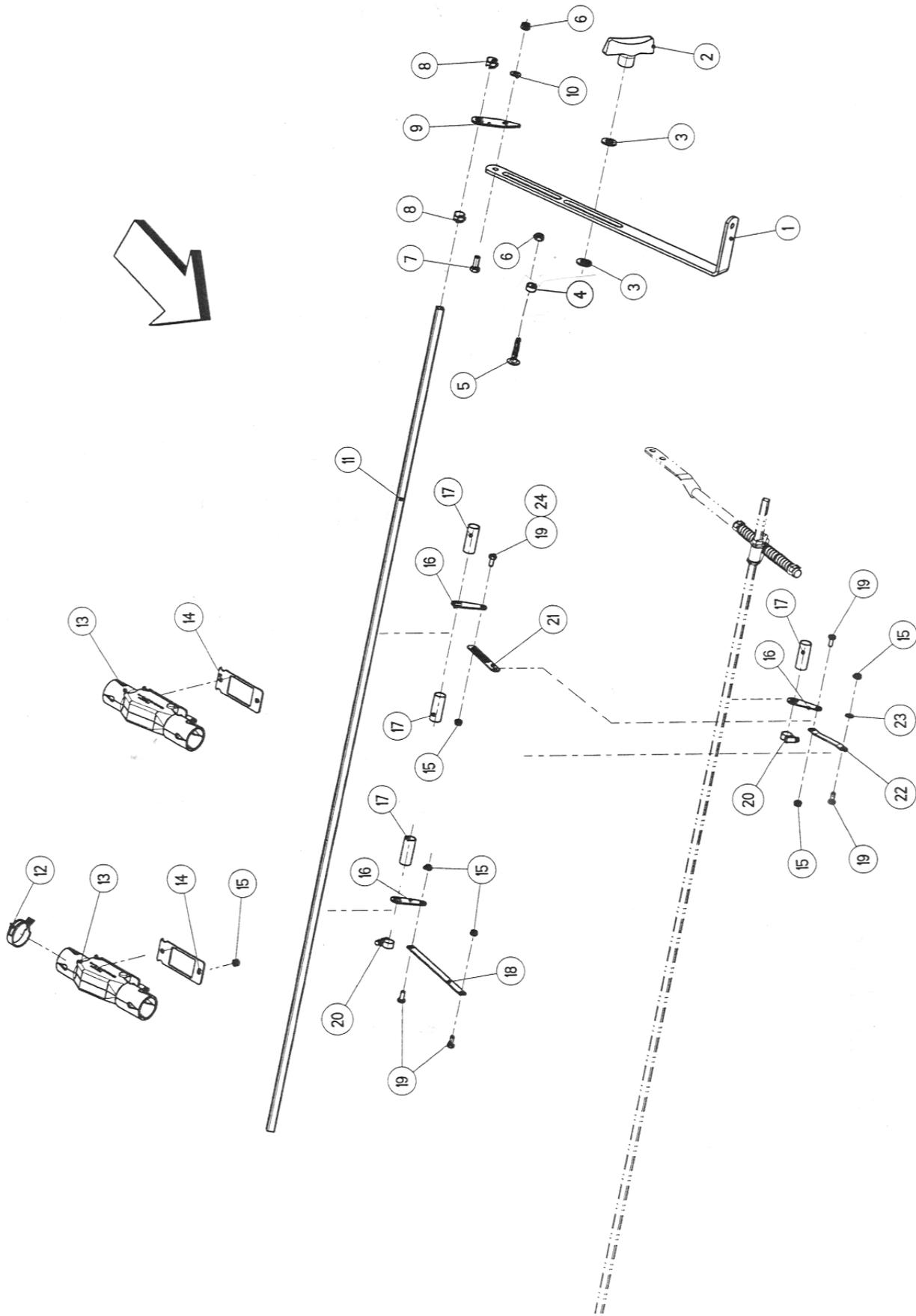



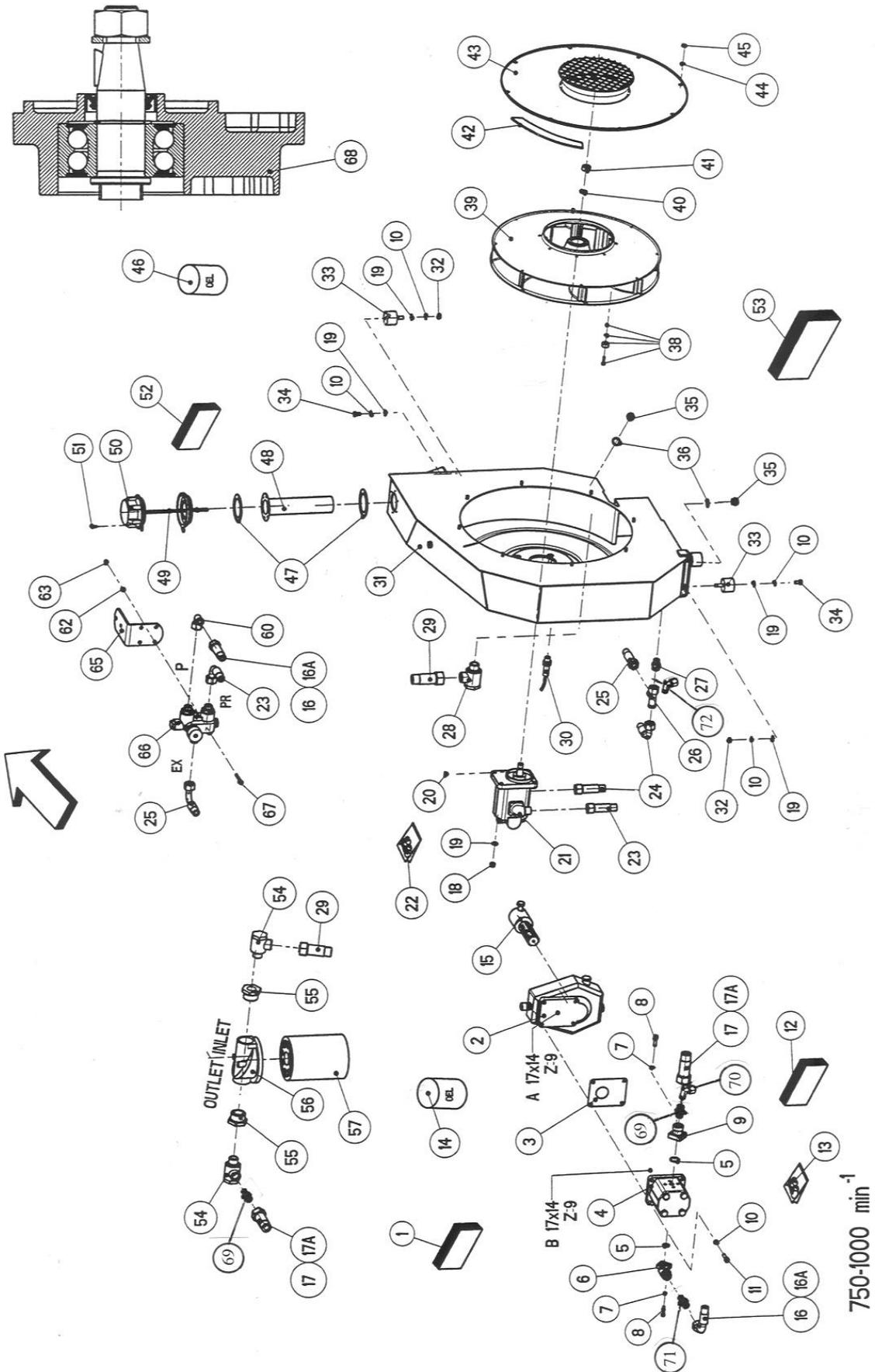

Varioblæser system-Vario blower system-Vario gebläse system-Animation vario

Pos.nr.	Del nr.	Benævnelse	Description	Beschreibung	Désignation
Picture	Part nr.				
Bild nr.	Teil nr.				
Dessin	No.de p.				
1	333230709	Drivenhed, kpl. gear+pumpe	Gear multipl. Cpl. 6 splines	Getriebeeinheit, 750-1000	Boîtier multip. Cpl.
2	333230713	Gearkasse 1000 o/min, 6	Gearmultiplier	Getriebe, 1 3/8"	Boîtier multiplicier
3	332007521	Tætning	Seal	Dichtung	Joint
4	333230715	Hydraulikpumpe 22ccm	Hydraulic pump	Zahnradpumpe	Pompe
5	332033313	O-ring 24x2,5mm	O-ring	O-ring	Joint torique
6	332009931	Vinkelfl., M22x1,5 fig.5-8	Elbow flange coupling	W-flansschv.	U. simple a bride en equerre
8	332126468	Skrue, M8x25	Head cap screw	Zyl.-schr.	Vis chc
9	332009925	Flange lige, M30x2	Straight flange coupling	Gerade flansschv.	Bride droite
10	332115341	Fjederskive, ø8	Spring washer	Federring	Rondelle Ressort
11	332126421	Skrue, M8x30	Head cap screw	Zyl.-schr.	Vis chc
12	333230717	Hydr.-pumpe kpl. fig.4-9	Hydraulic pump 22ccm cpl.	Zahnradpumpe kpl.	Pompe 22ccm cpl.
13	332053506	Pakningssæt f. hydr. pumpe	Set of oil seals	Dichtungssatz	Collection de joints
14	334230083	Gear olie, 0,2l. Meropa220	Gearbox oil	Getriebeöl	Huile pour carter
15	332152322	Reduc.- aksel 8x32x38-(6)	Reducer	Reduziert.	Mancon reducteur
16	045-7055	Hydraulikslange, 30x6700	Hydraulic hose	Hydro-schl.	Tuyau flexible
17	045-7050	Hydraulikslange, 36x6700	Hydraulic hose	Hydro-schl.	Tuyau flexible
18	332123770	Låsemøtrik, M8	Self-locking hexagon nut	6-kt-mutter sich.	Ecrou H
19	332115639	Skive, ø8,4	Flat washer	U-scheibe	Rondelle plate
20	332019284	Feder, 4x6,5	Woodruff key	Scheibenfeder	Clavette disque
21	333230708	Hydraulikmotor 11ccm kpl.	Hydraulic motor	Zahnradmotor	Moteur hydraulique
22	332053540	Pakningssæt f. hydr. motor	Set of oil seals	Dichtungssatz	Collection de joints
23	332052466	Hy.slange M22x1,5 550mm	Hydraulic hose	Hydro-schl.	Tuyau flexible
24	332052466	Hy.slange M22x1,5 550mm	Hydraulic hose	Hydro-schl.	Tuyau flexible
25	332052466	Hy.slange M22x1,5 550mm	Hydraulic hose	Hydro-schl.	Tuyau flexible
26	332009912	T-nippel m. oml., M22x1,5	Standpipe run tee	Einstellb.l - verschraubung	Te renverse orientable
27	332035184	Brystnipp., M18x1,5/22x1,5	Male stud coupling	Gerade einsch-ver.	Union male
28	332009917	Banjo kobling 3/4"/M30x2	Choke free banjo coupling	Drosself. W-schw-ver.	Racc.orientable a passage int.
29	0454140	Hydr.sl., M30x2 330mm	Hydraulic hose	Hydro-schl.	Tuyau flexible
30	332052774	Reed sensor, m. 2m. kabel	Sensor with cable	Reed- sensor mit kabel	Capteur avec cable
31	332052769	Blæserhus	Fan housing	Gehäuse/gebläse	Bloc turbine
32	332125514	Møtrik, M8	Hexagon nut	6-kt-mutter	Ecrou H
33	332045009	Gummifod, 40x30	Silent bloc	Gummi-metall-puffer	Amortisseur
34	332123734	Stålbolt, M8x14	Hexagon screw	6-kt-schr.	Vis H
35	332101236	Prop, M18x1,5	Hexagon pipe plug	Verschl-schr.	Bouchon filete
36	332117456	Kobberskive 18x24x1,5	Copper sealing ring	CU-di-ring	Joint en cuivre
38	332045079	Magnet, D20x10	Magnet	Magnet	Aimant
39	334230360	Blæserhjul kpl.	Fan impeller cpl.	Läuferrad mit deckel kpl.	Volant de turbine cpl.
40	332115330	Fjederskive B14	Spring washer	Federring	Rondelle ressort
41	332125537	Møtrik, M14x1,5	Hexagon nut	6-kt-mutter	Ecrou H
42	333104391	Tætning, 30x2x1600	Seal	Zellband	Joint
43	334104079	Dæksel	Cover	Gebläsedeckel	Couvercle
44	332015601	Skive 6,5x13x1	Flat washer	U-scheibe	Rondelle plate
45	332123762	Møtrik, M6	Hexagon nut	6-kt-mutter	Ecrou H
46	334230109	Hydraulikolie, 18,5L	Hydraulic oil	Hydrauliköl	Huile de soufflerie
47	332033301	Tætning, 82x57x1mm	Seal	Dichtung	Joint
48	332033356	Oliesi 200mm stål	Oil screen	Ölsieb	Crepine
49	332033304	Oliepind 200mm lang	Dipstick	Ölmesstab	Indicateur d'huile
50	332033302	Udluftningsfilter	Breather filter	Belüftungsfilter	Reniflard
51	332139906	Selvskærende skrue, 8x16	Self tapping screw	Blechschr.	Vis a tole
52	332010716	Oliepåfyldning kpl. fig.47-50	Filler breather filter	Einfüll-u. Belüftungsfilter	Crepine et reniflard
53	334230361	Blæser kpl. med motor	Gebläsekasten kpl.	Fan housing cpl.	Bloc turbine cpl.
54	332009917	Banjo kobling 3/4"/M30x2	Choke free banjo coupling	Drosself. W-schw-ver.	Racc.orientable a passage int.
55	332009919	Reducering, 1 1/4"x3/4"	Straight reducing coupling	Reduzierung	Raccord de reduction
56	334230042	Oliefilter kpl. fig. 54-57	Oil filter cpl.	Maxiflow/patronenfilter kpl.	Filtre cpl.
57	332033305	Filter	Filter cartridge	Filterpatrone	Cartouche de filtration
60	0446710	Brystnippel, ø22x3/4"	Hexagon nipple	Brustnippel	Raccord
62	332115636	Skive, 6,4	Flat washer	U-scheibe	Rondelle plate
63	332123769	Låsemøtrik, M6	Self-locking hexagon nut	6-kt-mutter sich.	Ecrou H
65	333230309	Beslag for ventil	Support plate	Montageblech für Ventil	Tole support
66	332054183	Flow kontrol ventil	Flow control valve	Stromregelventil	Valve de reglage du debit
68	332054129	Akselende m. dæksel kpl.	Drive end shield cpl.	Antriebslager kpl.	Flasque cote entrainement
69	044-7550	Forskruning, ø25/22L	Nipple	Nippel	Raccord
70	044-6690	Vinkel m. oml. m. O-ring	Standpipe elbow	Einstellbare winkelver.	Coude orientable
71	044-7540	Forskruning, ø22/15L	Nipple	Nippel	Raccord
72	332009906	Vinkel m. oml. M22x1,5	Standpipe elbow	Einstellbare winkelver.	Coude orientable

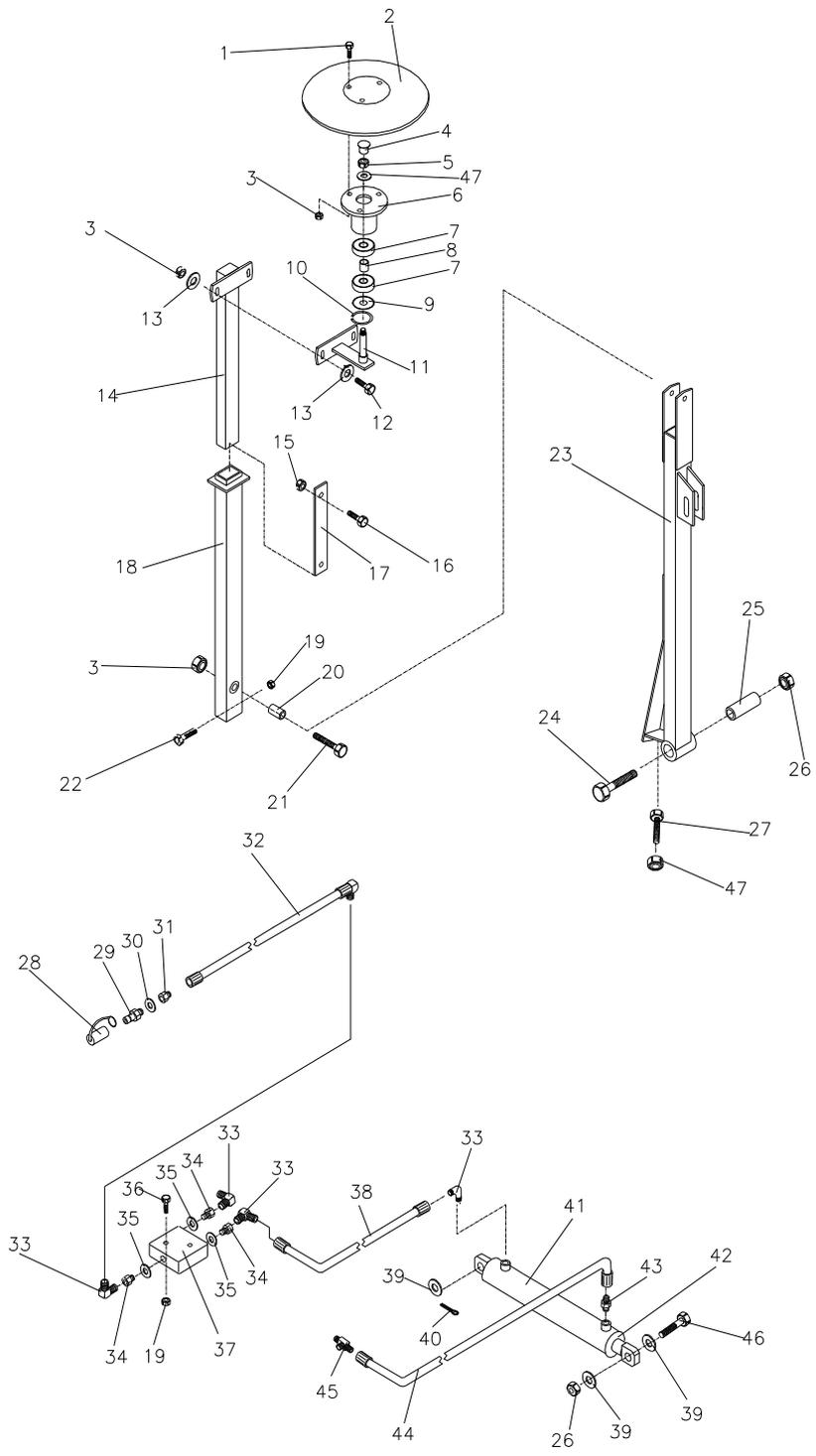



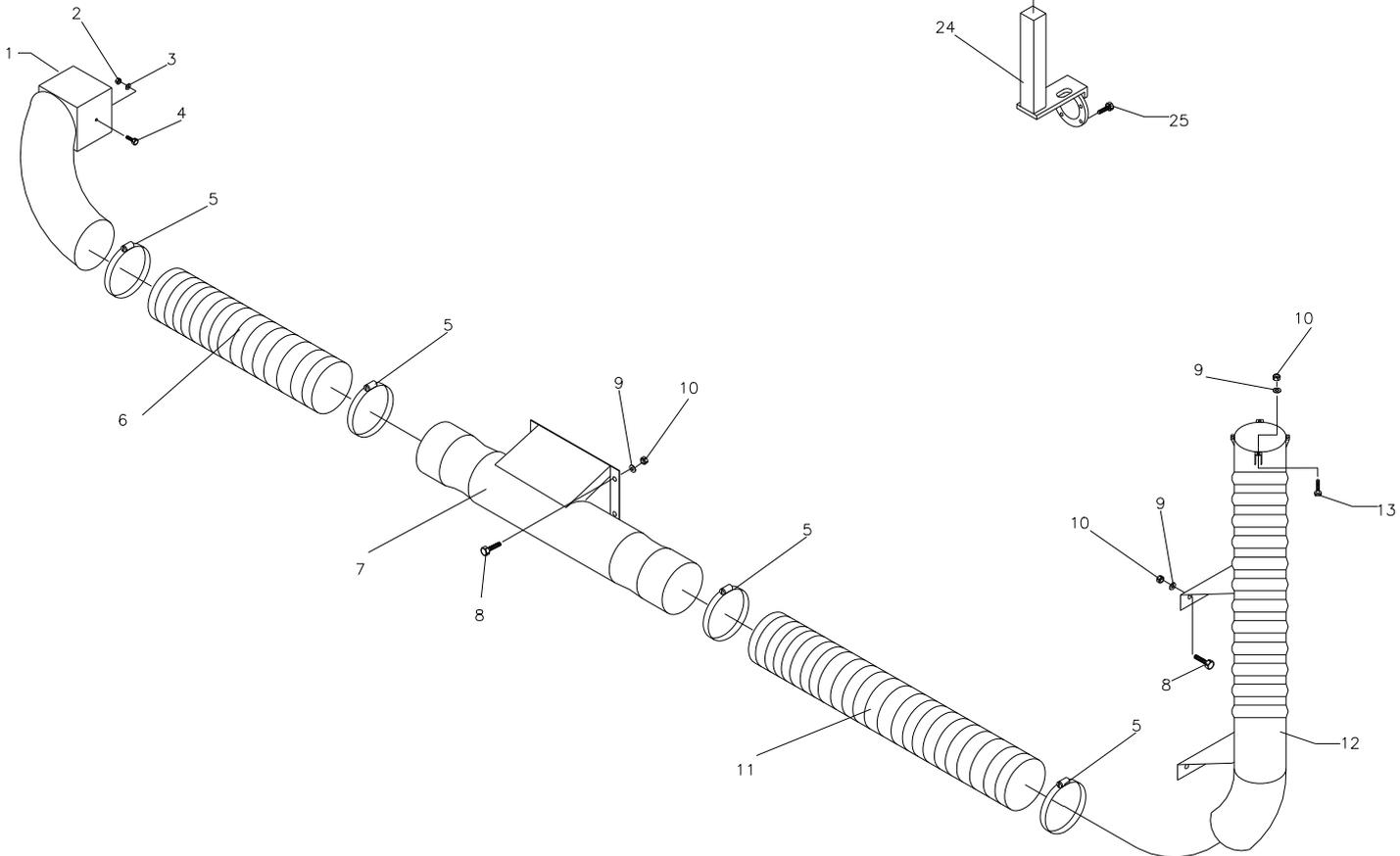
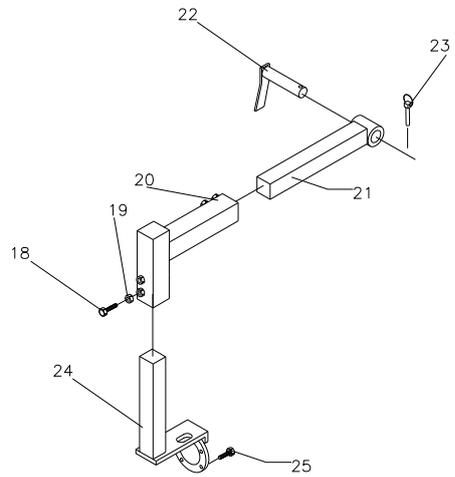
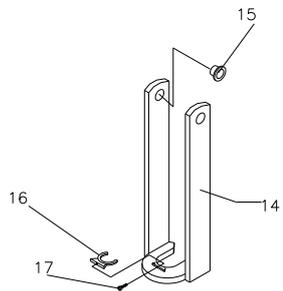



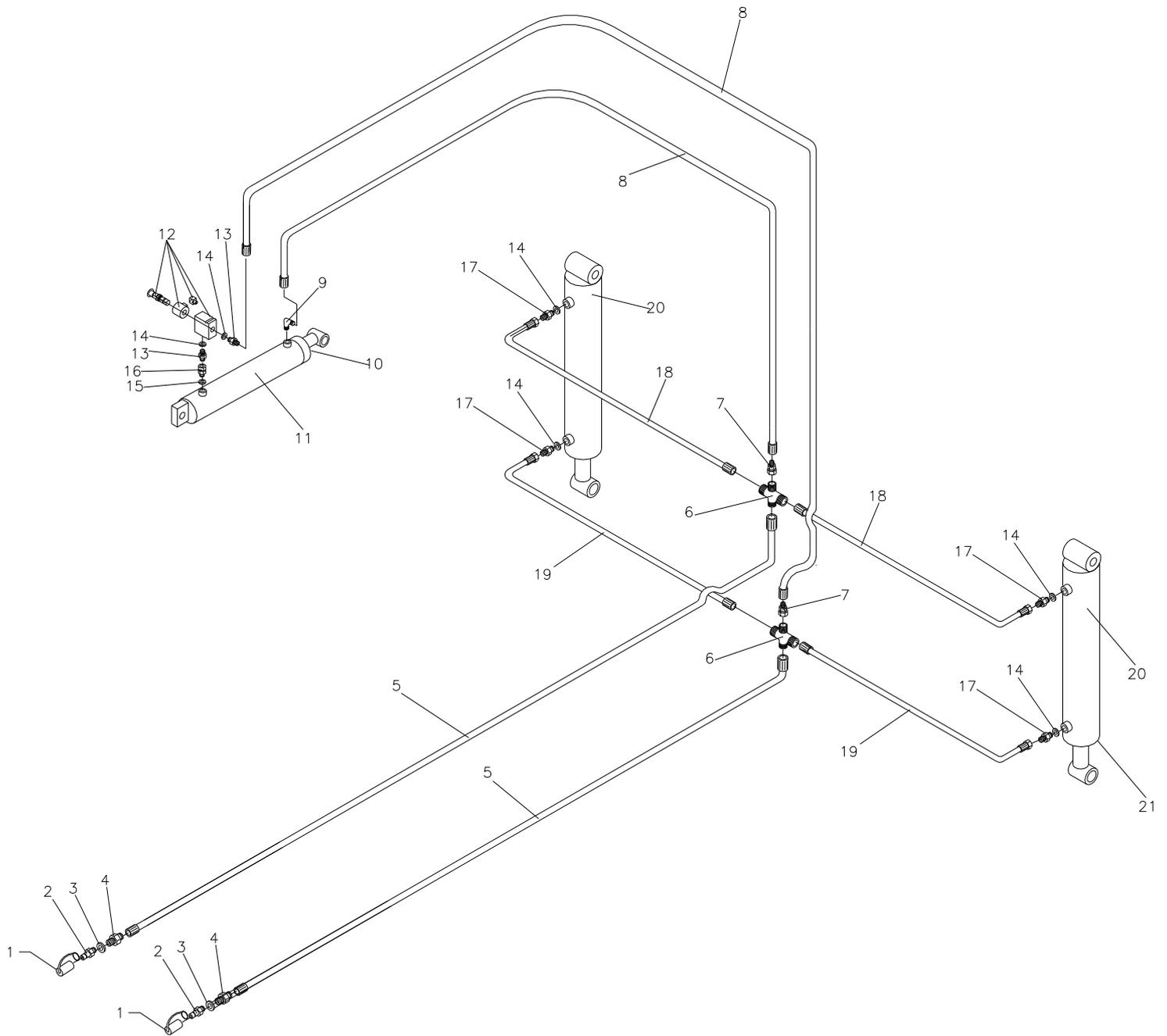



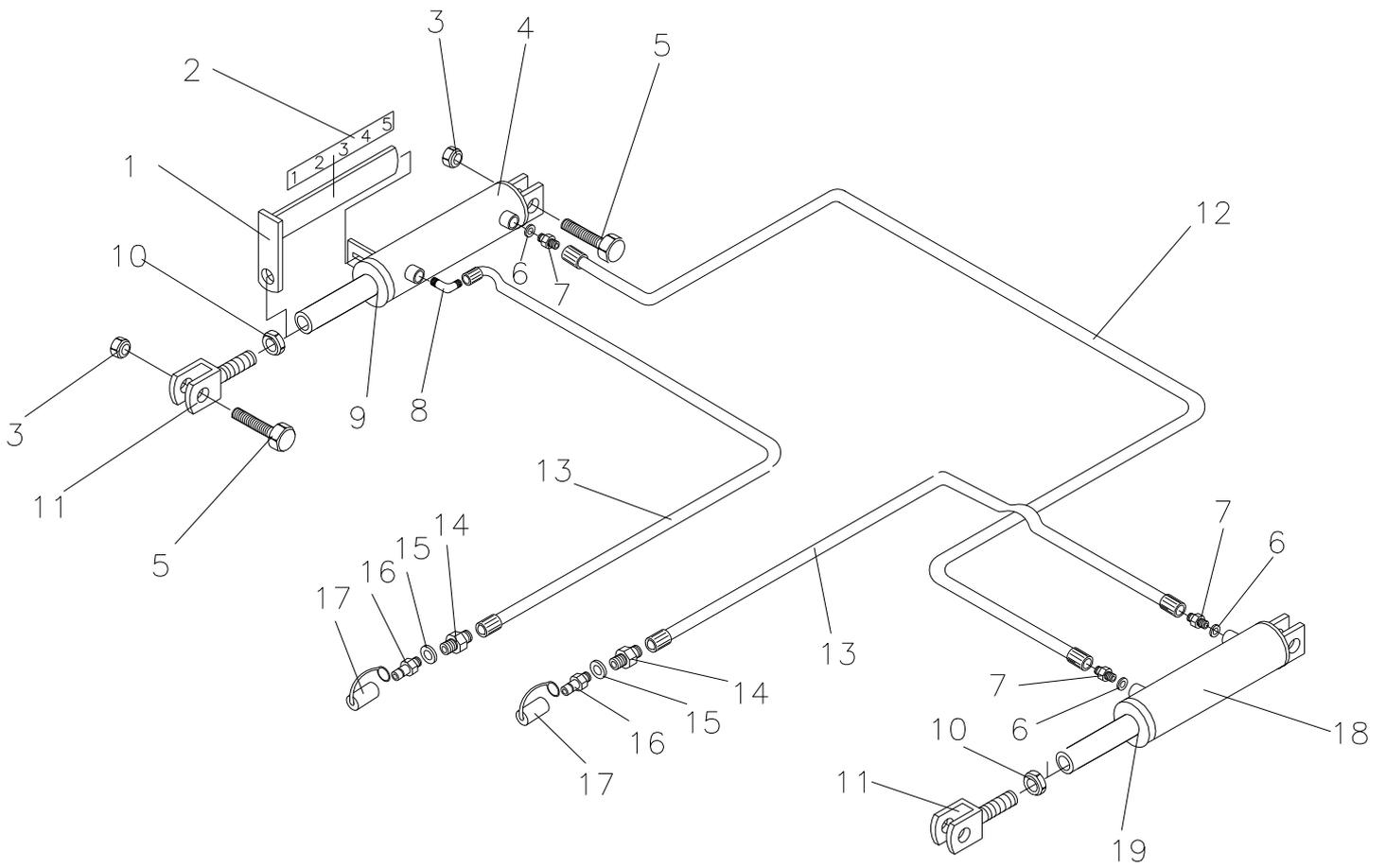



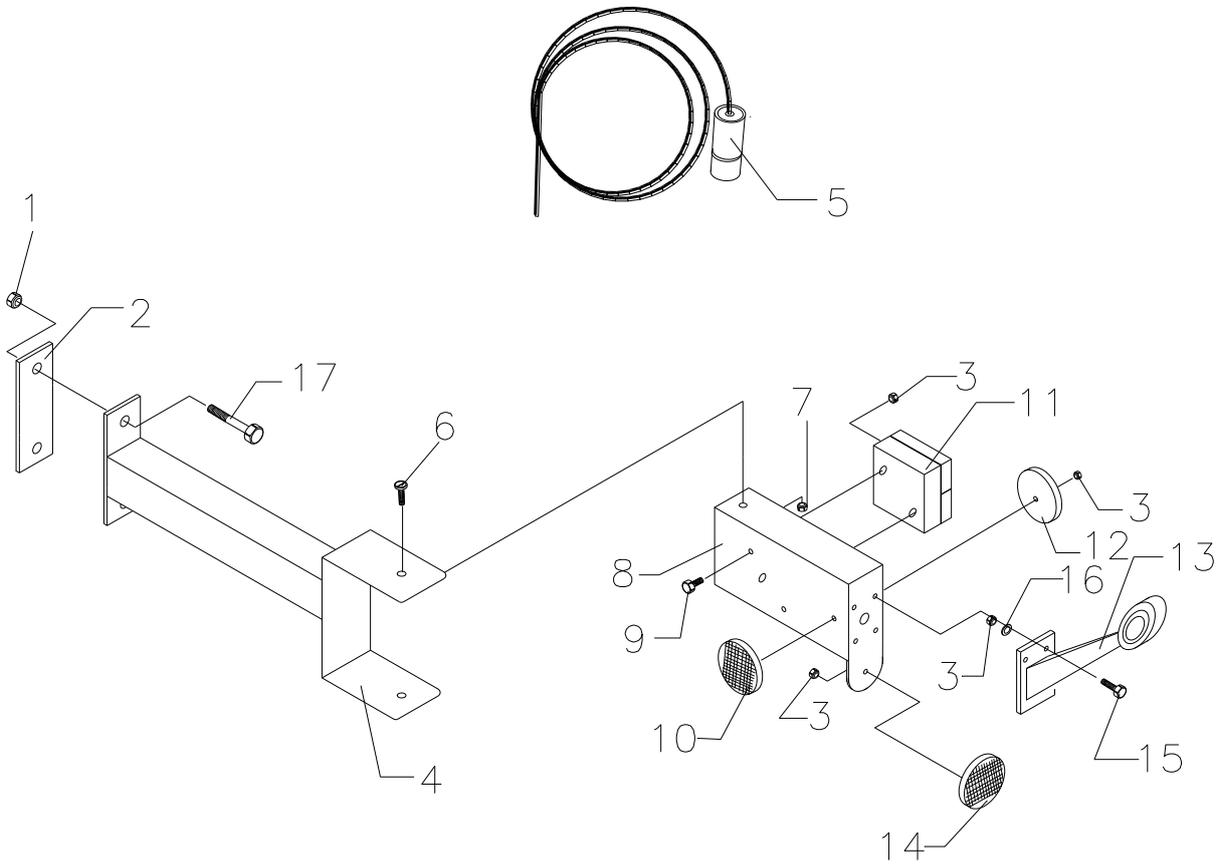







Ret til ændring i konstruktion og mål uden advarsel forbeholdes.

We reserve the right to change specifications, construction, etc., without notice or without liability.

Sämtliche Abbildungen und techn. Angaben unverbindlich. Konstruktionsänderungen vorbehalten.

Les caractéristiques techniques sont données à titre indicatif et nous réservons le droit de les modifier sans préavis.

