

CE

# HE-VA Auto-Controller

## AC-PLUS

### Installation, Calibration and Operation

Software Reference WZ410-001 rev.016



**Important:**  
Before using the machine,  
please study the Operating  
Instructions thoroughly to  
ensure that you are familiar  
with the safety instructions.

**HE-VA**

N. A. Christensensvej 34  
DK-7900 Nykøbing Mors  
Tel: +45 9772 4288  
Fax: +45 9772 2112  
[www.he-va.com](http://www.he-va.com)

# Contents

<b>1.</b>	<b>Overview</b>	<b>4</b>
1.1	Programming Modes	5
<b>2.</b>	<b>Installation</b>	<b>6</b>
2.1	The Head Unit	8
2.2	The 'Tractor Terminator Assembly'	9
2.3	Power supply	10
2.4	Radar sensor	10
2.5	Cutout switch	11
<b>3.</b>	<b>Normal Operating Mode</b>	<b>12</b>
3.1	Operating Summary	12
3.2	Power On/Off	13
3.3	Work Status Indicator	13
3.4	Starting and Stopping the Seeder	13
3.5	Motor Alarms	14
3.6	Pre-start function	14
3.7	Cutout Alarm	14
3.8	Simulated Speed	15
3.9	Application Rate – Kg/Ha or Seeds/m <sup>2</sup>	15
<b>4</b>	<b>Forward Speed Display</b>	<b>16</b>
4.1	View Forward Speed	16
4.2	Minimum Speed Alarm	16
4.3	Speed Sensor Calibration	16
4.4	'Autocal' Speed Calibration	17
<b>5</b>	<b>Area Display</b>	<b>18</b>
5.1	View Area Totals	18
5.2	Zero Area Total	18
5.3	Set Implement Width	19
<b>6.</b>	<b>Drilling Rate Functions</b>	<b>20</b>
6.1	View Drilling Rate	20
6.2	Adjusting the Drilling Rate	20
6.3	Drilling Rate Indicator	20
6.4	Changing the Target Rate	21

---

6.5	Product Calibration.....	22
6.6	Set "Thousand Grain Weight" .....	23
6.7	Select Unit.....	24
6.8	Set % Step for Rate Offset.....	24
<b>7.</b>	<b><i>Fan Display</i></b> .....	<b>25</b>
7.1	View Fan Status.....	25
7.2	Fan Status Alarm .....	25
<b>8.</b>	<b><i>Hopper level Alarm</i></b> .....	<b>25</b>
8.1	Feed roll monitoring .....	25
<b>9.</b>	<b><i>Programme Functions and Fault Diagnosis</i></b> .....	<b>26</b>
9.1	Programme Modes 1 – 5.....	26
9.2	Fault Diagnosis .....	27
<b>10.</b>	<b><i>Calibration Record</i></b> .....	<b>28</b>
<b>11.</b>	<b><i>Spare part list</i></b> .....	<b>29</b>

## 1. Overview

The HE-VA Auto-Controller enables fully automatic control of the seed rate of the HE-VA Multi-Seeder.

The HE-VA Auto-Controller automatically maintains a preset application rate as forward speed varies, with on-the-go adjustment of rate. The instrument measures and indicates:

- Forward Speed
- Part Area and Total Area worked
- Seed Application Rate (kg/ha or Seed/m<sup>2</sup>)
- Fan Status (On/Off)
- Low Hopper Level

There are also audible and display alarms for,

- Fan off
- Minimum / maximum forward speed (beyond which the programmed seed rate cannot be maintained).
- Feed motor stopped (no feedback)
- Feed motor stalled

The head unit is powered on and off via a toggle switch on the rear of the instrument.

A second switchbox in the cab is used to switch the fans on and off as well as the feed motor. The feed motor is also switched on and off *automatically* via the implement-mounted cutout finger switch as the implement is raised and lowered.

Area totals and all calibration data are automatically stored in memory when the instrument is powered off.

The system must be initially calibrated for the seed being applied. Seed calibration is very simple to undertake via a priming switch provided on the junction box fitted on the Multi-Seeder. The junction box has an on-off switch to switch the fans off during calibration, and an on-off switch to operate the agitator shaft when sowing grass.

*NOTE: The instrument front panel appearance may be slightly different to that illustrated.*

## **1.1 Programming Modes**

There are 5 programming modes with various calibration factors and default settings. Access to the programming modes is required for some settings which may be changed as part of the normal operating procedure. Changing these settings is described with the operation instructions (sections 4,5,6,7,and 8).

Other settings are made on installation and do not normally need to be changed. These settings are appended to in the back of this manual (section 9). The operator does not normally need to refer to them.

## 2. Installation

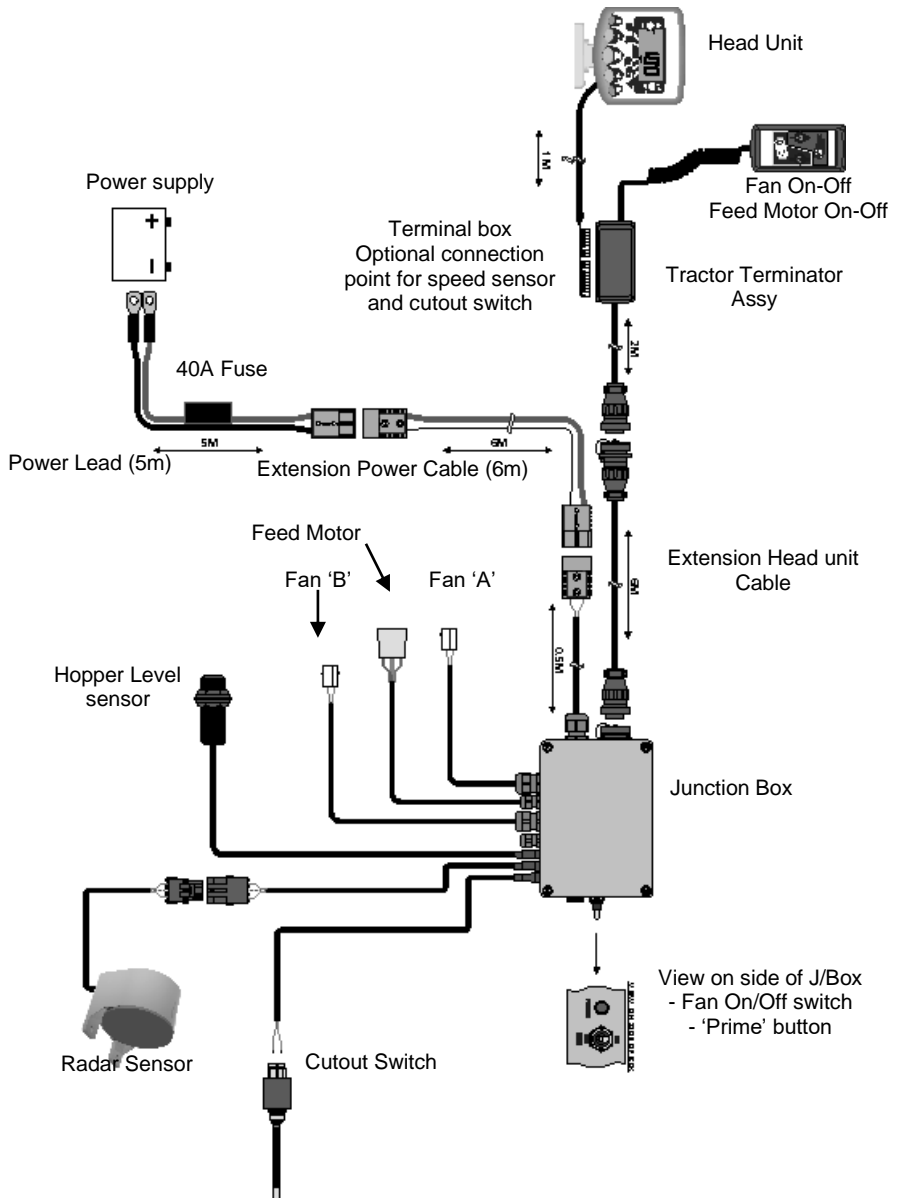

Most of the components integral to the HE-VA Auto-Controller are factory fitted. The remaining components need to be installed by the end user,

- Head Unit
- Tractor Terminator Assy
- Power cable from battery
- Radar Sensor (mounted onto the implement).
- Finger Cutout Switch (mounted onto the implement)

Separate heavy-duty power cable and head unit leads interconnect the tractor and the HE-VA Auto-Controller. 4m and 10m versions are also available to suit the length of the implement train.

*NOTE: The recommended maximum combined length of power cabling from battery to junction box is 30m.*

## 2.1 The Head Unit

Confirm with the operator on where to mount the head unit in the cab. It must not restrict the view out of the cab, nor impede the use of the controls. The head unit is fitted with a 1-metre flying lead terminating with an 8/10-way IDC type connector, ready for connection into the "Terminator" junction box.

The head unit is supplied with a mounting kit comprising the following parts (fig. 2):

- 1 Long Bracket
- 1 Short Bracket
- 3 Clamping Knobs
- 1 Cover Plate
- 1 Mounting Plate
- 2 Self Tapping Screws

1. Snap the cover plate into the recess of the long bracket (it only fits one way).
2. The instrument mount is designed to offer maximum flexibility in positioning the head unit, either from the right hand side of the cab, from the dashboard or from an overhead position.

Assemble the two brackets, and mounting plate with clamping knobs, and attach to the head unit.

*NOTE: Either the long or short bracket can be attached to the head unit, whichever gives the most suitable orientation.*

Having established the orientation for the bracket, fix the mounting plate to the cab with the self tapping screws provided.



**Do not drill into a ROPS or FOPS frame.**

If you are fixing the mounting plate to plastic e.g. the dashboard or other cab moulding, it is recommended to use M4 screws with mudwing washers to strengthen the mounting point.



**Do not attempt to adjust the mounting bracket assembly without first slackening off the clamping knobs sufficiently. You will only succeed in damaging the bracket otherwise.**



Figure 2 : Head Unit Mounting Kit



## 2.2 The 'Tractor Terminator Assembly'

Mount the Fan/Metering Switch box in a convenient position using the second mounting kit (ref. section 2.1).

Remove the lid of the terminal box by squeezing the sides and connect the head unit lead as shown in figure 3 below.

The Terminator is not a waterproof enclosure. Locate it where it is afforded protection from possible water ingress and for neatness e.g. behind a trim panel or console.

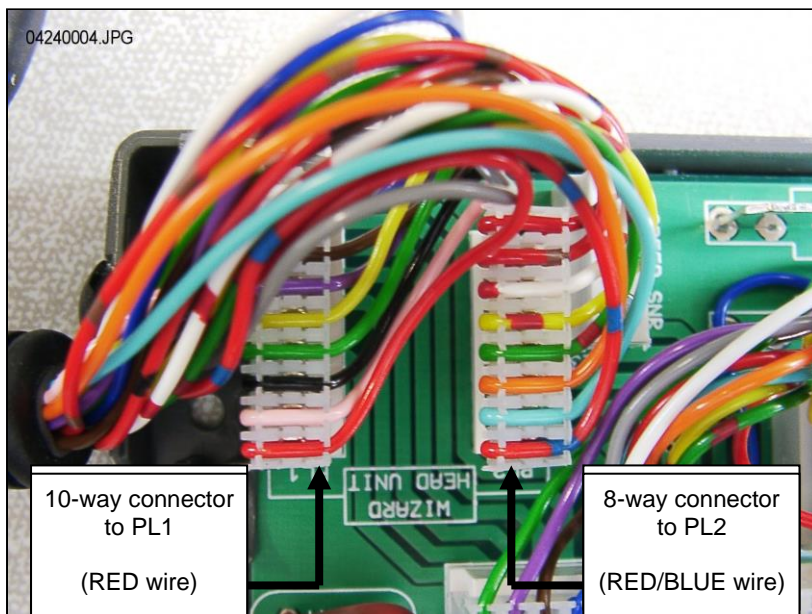

Figure 3 : Head unit connection

**NOTE:** The head unit receives its power supply from the junction box. The power supply terminals in the Terminator are not used. The circular (CPC) connector trails to the back of the tractor to connect up to the extension lead.

## 2.3 Power supply

Connect the power supply cable to the battery terminals and route the cable to the rear of the tractor. Where possible follow the existing wiring loom and secure at regular intervals using the cable ties provided.

**NOTE:** *The system has reverse polarity protection. If by chance the battery connections are reversed, the system will simply not function.*

The power cable is fitted with an inline 40-amp fuse. For spare fuse links, specify DURITE Pt No. 0-378-40 (or similar). Do NOT be tempted to fit a higher rated fuse!

## 2.4 Radar sensor

Mount the radar sensor 30 – 80 cm above the ground, and in a 45° angle.

The sensor can point forward or to the rear, this will not influence the signal.

However, the sensor signal might be disturbed by outside influences, such as hydraulic hoses or unsteady soil, causing an inaccurate dosage.

### **Connecting a drill-mounted radar sensor (standard):**

Simply connect the radar sensor lead to the lead from the HE-VA Auto-Controller junction box (3-way Weatherpak connector). Coil any excess lead near the junction box and secure the lead from the sensor at regular intervals using the cable ties **provided**.

### **Connecting a tractor-mounted radar sensor:**

Open the HE-VA Auto-Controller junction box and remove the sensor extension lead with the 3-way WeatherPak connector (fig. 4). Plug the hole to prevent water ingress.

Figure 4

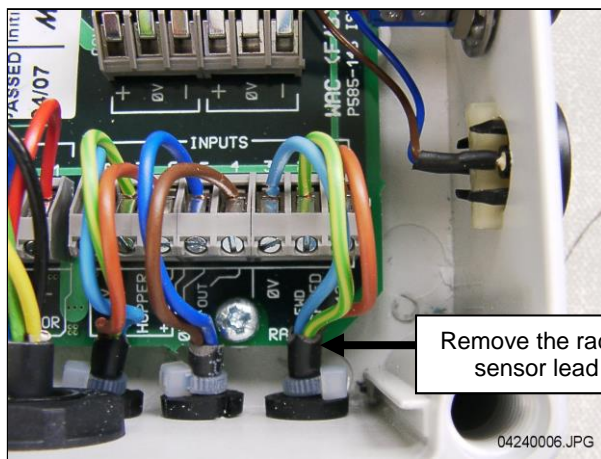

Connect the extension lead to the sensor and route back to the Terminator junction box. Where possible follow the existing wiring loom and secure at regular intervals using the cable ties provided.

Remove the lid of the terminal box by squeezing the sides, cut off excess cable length and connect the head unit lead as shown in figure 5 below.

Figure 5

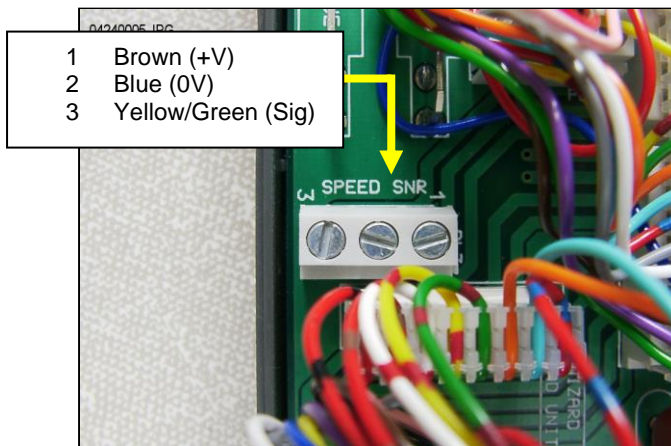

The default speed sensor calibration factor (SSF) programmed in the head unit = '7.78' (millimeters/pulse). This is theoretically correct for the radar sensor when it is installed at exactly the specified angle to the ground. Often though, the sensor may not be exactly at the prescribed angle. It is therefore recommended that to ensure accurate speed measurement, you check the calibration value by performing an 'Autocal' procedure (please refer to section 4.4).

## 2.5 Cutout switch

The implement-mounted cutout finger switch enables the system to automatically start and stop operation as the implement is lifted and lowered. It therefore needs to be mounted in a suitable position to operate as the implement enters work.

The brackets included can be mounted by the top link shank, as shown here:

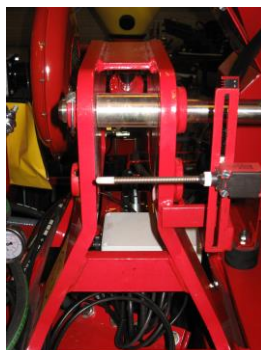

### 3. Normal Operating Mode

#### 3.1 Operating Summary

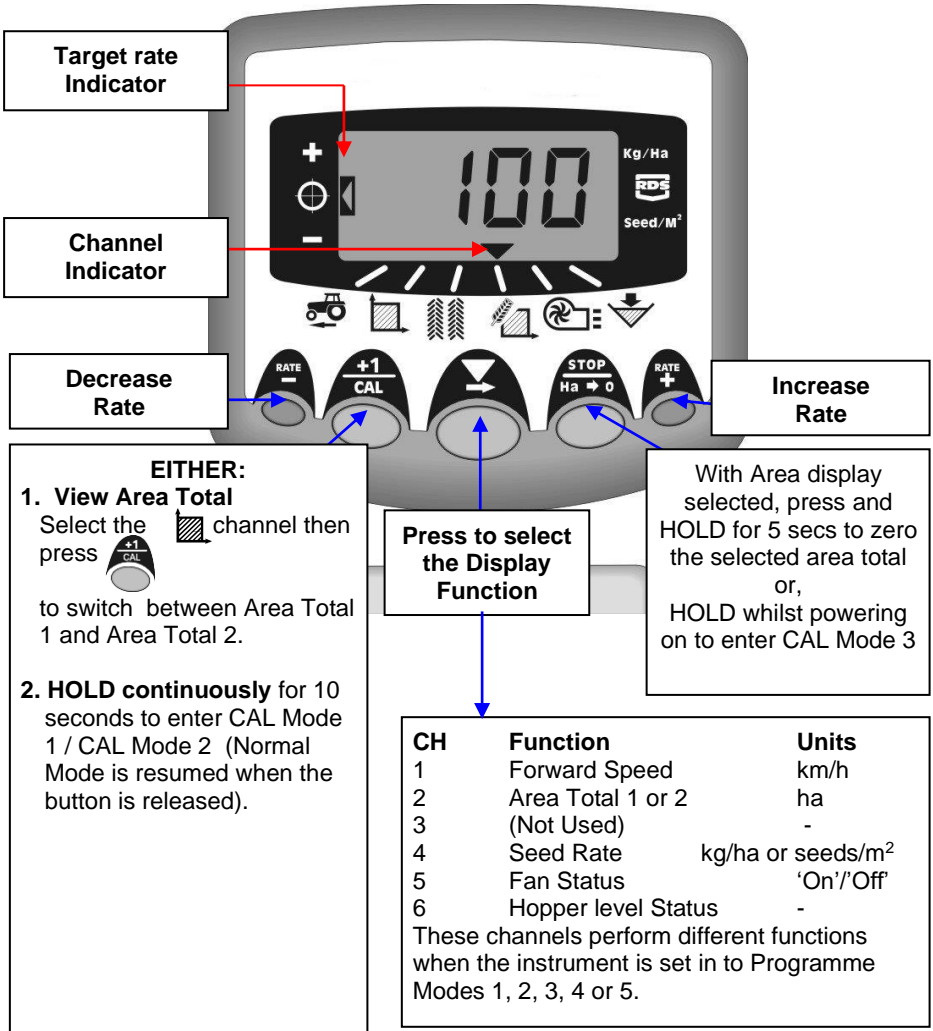

### 3.2 Power On/Off

Switch the head unit on via the toggle switch on the rear of the instrument.

The instrument powers up and displays the software version installed e.g. 'A410' then 'E001' then 'R016' (software version WZ410-001 rev.16). It then enters its normal operating mode and displays the forward speed channel.

Select any other channel by pressing the ▼ button once or more.

When the Multi-Seeder is out of work, the instrument will continue to display the selected channel.

### 3.3 Work Status Indicator

The ▼ indicator is used to indicate the channel to which the information on the display relates.

It also shows the working status of the Multi-Seeder. If the cursor is flashing then the Multi-Seeder is out of work, if the cursor is on continuously then the Multi-Seeder is in work.

### 3.4 Starting and Stopping the Seeder

The hand control is used,

- (i) to switch the fans on and off.

*NOTE: The fan switch on the HE-VA Auto-Controller junction box must be set in the 'I' position.*

*This junction box switch is provided to disable the fan and enable product calibration using the 'PRIME' button.*

- (ii) to manually switch the feed motor on and off when the Multi-Seeder in work\*.

The Multi-Seeder is also fitted with a cutout finger switch so that the feed motor starts and stops automatically when the implement is lowered and raised e.g. on the headlands.

\* *The feed motor switch on the hand controller is not effective when the implement is raised out of work.*



### 3.5 Motor Alarms

#### Motor stoppage

The system monitors the motor drive during work. If the motor stops for any reason (other than stalling), the instrument display defaults to channel 4 (Seed Rate), flashes "**FAIL**" and beeps every 30 seconds. The power to the motor is automatically switched off.

Switch the instrument off and then on again to reset the alarm. If the alarm reoccurs, then contact a service representative.

#### Motor Stalled

If the motor stalls (e.g. a problem with the metering unit), the instrument display defaults to channel 4 (Seed Rate), flashes "**StAL**" and beeps every 30 seconds. The power to the motor is automatically switched off.

Switch the instrument off and then on again to reset the alarm. If the alarm reoccurs, switch the system off and check the metering unit is not blocked or jammed.

### 3.6 Pre-start function

On commencing a bout, the seed motor only starts as you begin moving off, in proportion to your forward speed. However, it takes a short period for the seed to traverse the pipe to the coulter. The result is an unseeded area at the beginning of a bout.

To avoid unseeded patches due to the delay in seed delivery, once positioned and stationary at the start of the bout, press the outside right switch ("RATE +"). The pre-start function is activated and the motor then runs at the calibration speed, so that seed is planted as you move off.

The pre-start function is timed to run the motor at the calibration speed for a number of seconds equal to the implement width in metres (e.g. 4m implement = 4 seconds pre-start). After this time and the implement is moving forwards, the system reverts to normal proportional control for the seed rate set.

However, if after this time the implement is still stationary, the motor will automatically switch off.

*NOTE: The default pre-start time is 4 seconds, however it can be changed if required in Cal Mode 2-Channel 6 (ref. section 9).*

### 3.7 Cutout Alarm

If the forward speed exceeds 2km/h with the Multi-Seeder 'out of work', the instrument will alarm by beeping and flashing '**C.out**' every 5 seconds. The alarm will continue until the implement is lowered into work. The forward speed at which this alarm is displayed can be modified by entering Cal Mode 5 and adjusting the speed on channel 1. If set to 8.00 then it will not alarm until above 8 km/h

### **3.8 Simulated Speed**

If there is a problem with the forward speed or for testing, a 'Simulated Speed' can be used on the instrument. To enable this, disconnect the speed sensor. Enter Mode 2 and while on channel 1, use the + and – buttons to set a simulated speed value. Once the correct speed is selected, press the Ha-0 button and the instrument will now use this speed until it is next powered down.

### **3.9 Application Rate – Kg/Ha or Seeds/m<sup>2</sup>**

The system can display application rate in either Kg/Ha or Seeds/m<sup>2</sup>. To switch between the two settings, enter Cal Mode 3 and switch between 'Rate' kg/ha or 'Pop' seeds/m<sup>2</sup> on channel 1. The Thousand Grain Weight for that seed can then be entered on channel 2.

.

## 4 Forward Speed Display

### 4.1 View Forward Speed



The forward speed is derived from a radar sensor fitted either to the implement or the tractor depending on your particular installation.

The speed is displayed in km/h only.



Figure 6 : Select Fwd. Speed

### 4.2 Minimum Speed Alarm

As part of product calibration, based on the resulting calibration factor, the instrument automatically calculates the minimum forward speed below which the system cannot maintain the programmed seed rate.

With the Multi-Seeder in work, if the forward speed goes below this threshold the instrument display defaults to channel 1, flashes the actual speed and beeps continuously. The alarm will continue until speed is increased above the threshold. It may be cancelled temporarily by selecting another channel but will revert to channel 1 and repeat the alarm after 30 seconds until speed is increased.

*NOTE: The application rate will not remain proportional below the minimum speed threshold. The feed motor cannot run below 3 rpm resulting in over-application.*

### 4.3 Speed Sensor Calibration



The forward speed is derived from the speed sensor factor (SSF) – the distance travelled in millimetres for each pulse received from the radar speed sensor. The default factor is 7.8mm per pulse from the sensor, however this will only result in a correct speed display if the sensor has been mounted at the correct angle to the ground.

Failure to correctly programme the speed sensor factor will also result in the drilling rate being displayed incorrectly. Auto-calibration is likely to be more accurate than manual calibration, and therefore it is recommended to perform an "Autocal" routine (see below).



## 4.4 'Autocal' Speed Calibration

Auto-calibrate in field conditions for maximum accuracy.

1. Place two markers 100 metres apart and position some reference point on the tractor (e.g. the cab step), opposite the first marker.
2. Select the forward speed channel.
3. Press and hold the  button until the cal factor appears on the display. (7.8)
4. Continue holding the  button and press the  button.

The display will show "AUto" ready to start the test run (fig. 2).

5. Drive up to the second marker and stop exactly opposite the marker. The instrument counts and displays the pulses received from the speed sensor over the measured distance.

**NOTE:** As the instrument only displays up to 9999. Beyond this number of pulses it displays the first 4 digits of a five digit number, however the pulses are still being counted internally.

6. Press the  button (fig. 8). The calibration factor is automatically calculated and stored in memory. The instrument then returns to the normal display mode.

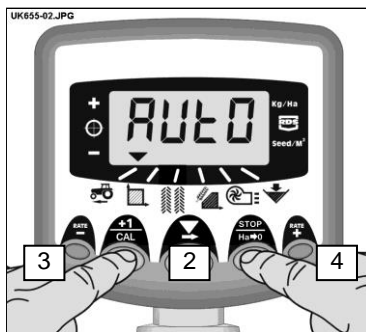

Figure 7 : Start AutoCal

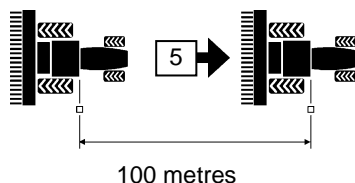

Figure 8 : Stop Autocal

## 5 Area Display

### 5.1 View Area Totals



The area display is derived from the forward speed input and the programmed implement width.

There are two area registers. Each can be independently reset to zero.

Press  to toggle between the two area registers 'tot.1' and 'tot.2'.

*The display then shows the area accumulated since that total was last reset.*

### 5.2 Zero Area Total

1. Select the total 1 or total 2 and release.
2. HOLD  for 5 seconds.

*The display flashes and the instrument gives 5 beeps, before the total resets to zero.*



Figure 9 : Select Area Channel



Figure 10 : Select Area Register 1 / 2

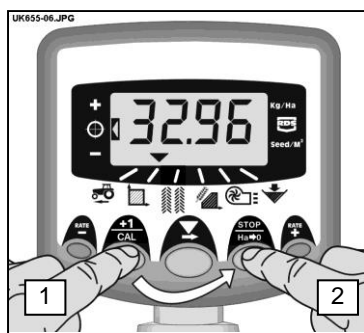



Figure 11 : Zero Area Total

### 5.3 Set Implement Width

1. Select the Area Total channel (  ).
2. Press and hold the  button for 5 seconds. The display will flash "tot.1", then "tot.2" then show the programmed implement width (fig. 12).

*Default width = 4 metres.*





3. Continue holding the  button and PRESS  to select the digit/decimal point to change.
4. HOLD  to change the digit (or move the decimal point). Releasing the button selects the next digit (fig. 13).
5. Release the  button to return to the normal display mode.



Figure 12 : View Implement



Figure 13 : Change Implement Width

## 6. Drilling Rate Functions

### 6.1 View Drilling Rate





This channel displays the current drilling rate in either Kg/Ha or Seeds/m<sup>2</sup>, depending upon the selection made in CAL Mode 3. The resolution for Kg/Ha units is:

0 to 24.9	0.1 Kg
25 to 250	1 Kg
250 to 9995	5 Kg

The resolution for Seeds/m<sup>2</sup> is 1 Seed/m<sup>2</sup>

### 6.2 Adjusting the Drilling Rate

Press the **RATE**  button to decrease the drilling rate.

Press the **RATE**  button to increase the drilling rate.

The rate adjusts by the % step programmed in programme mode 3, i.e. 5%, 10%, 15%, 20% or 25% of the programmed target or base drilling rate.

### 6.3 Drilling Rate Indicator

The left indicator is used to remind the operator of his drilling rate. When the indicator is in position 2, then the Multi-Seeder is operating at the target rate.

If the indicator is in position 1 then the actual rate is increased from the target rate.

If the indicator is in position 3 then the actual rate is decreased from the target rate.



Figure 14 : View Drilling Rate (kg/ha)

Pos. 1



Pos. 2



Pos. 3



## 6.4 Changing the Target Rate

If the drilling rate is currently at the target rate (the rate indicator is in position 2), then:-

1. With the rate display selected, press and hold either the **RATE**  $\oplus$  button or the **RATE**  $\ominus$  button for 5 seconds (fig. 15), then release the button. The display will flash.
2. Press and hold either the **RATE**  $\oplus$  button to increase the target rate, or the **RATE**  $\ominus$  button to decrease the target rate (fig. 16). The longer the switch is held, the faster the number changes.
3. When the desired target rate is displayed, press and hold the **RATE**  $\blacktriangledown$  button.

The instrument will beep 5 times and the display will alternate between the set rate and the calculated minimum forward speed for that rate. After 5 seconds the instrument will display '**done**' after which the button can be released to return to normal operating mode.



Figure 15 : View current Target Rate

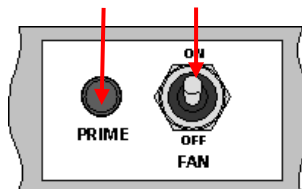

Figure 16: Adjust Target Rate

## 6.5 Product Calibration





Ensure the feed roll setup is appropriate for the intended seed type, application rate and forward speed range for application. Please refer to sections 5 and 6 of the HE-VA Operating Instructions if necessary.

1. Switch the 'FAN' switch to the off ('O') position on the junction box. This automatically enables the product calibration function.



2. Place a container under the seed outlet of the metering unit then press and hold the PRIME button to dispense the product.
3. The instrument automatically switches to the programme mode, and the display will count up the theoretical weight (in grams) of product based on the calibration factor currently stored in memory.
4. Once you have dispensed sufficient product, release the priming switch and weigh the product metered out. The theoretical weight will remain flashing on the display.

**NOTE:** If the priming switch is held for long enough to exceed 9999 grams then the instrument will simply show 'HiGh', informing the operator that he must re-test to ensure the weight does not exceed 9999 grams. Simply release the PRIME button and press again when ready to restart the count from zero.





5. Adjust the displayed weight to match the measured weight using the **RATE**  or **RATE**  buttons.
6. Press the  button once to display the calculated minimum forward speed (see note 2 below).
7. Press the  button again to save the new calibration factor. The instrument displays 'done' to indicate the new factor is now stored. After 3 seconds the instrument reverts back to the normal operating mode.
8. Switch the 'FAN' switch back on.

**NOTE 1:** If you display the drilling rate in Seeds/m<sup>2</sup>, check the T.G.W. (Thousand Grain Weight) setting is correct. (6.6).

**NOTE 2:** The instrument makes the calculation from the entered working width, target application rate, and the metered weight delivered whilst calibrating. If you find that you cannot achieve your desired field speed, then re-configure the feed roll assembly and repeat the calibration procedure.

## 6.6 Set "Thousand Grain Weight"

The T.G.W. must be set in order enable the instrument to display a drilling rate in Seeds/m<sup>2</sup> correctly.

1. Press and hold the  button as you switch the instrument on. The instrument is then in programme mode 3 on channel 1 (fig. 17).
2. Press  to select channel 2 (  ). The display will show the Thousand Grain Weight in grams.  
*Default = 45 (gram)*
3. PRESS  to select the digit/decimal point to change (fig. 18).
4. HOLD  to change the digit (or move the decimal point). Releasing the button selects the next digit.
5. Switch off and on again resume normal operating mode.

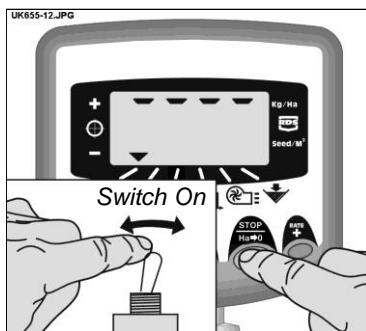



Figure 17 : Enter Cal Mode 3



Figure 18 : Adjust T.G.W. (Channel 2)

## 6.7 Select Unit

1. Press and hold the  button as you switch the instrument on. The instrument is then in programme mode 3 on channel 1 (fig. 17).

The display shows either the top row of segments to indicate the *kg/ha* unit is selected, or the bottom row of segments to indicate that the *Seeds/m<sup>2</sup>* unit is selected.

2. Press the  button to change units (fig. 19).

If the *Seeds/m<sup>2</sup>* unit is set, check the T.G.W. setting is correct for the product being drilled (6.6).

3. Switch off and on again to resume normal operating mode.

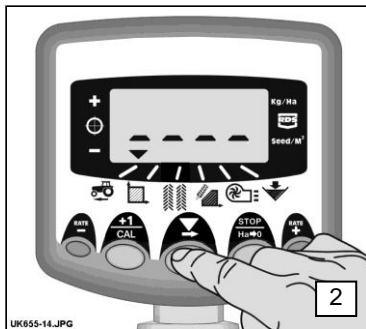







Figure 19: Change Units

## 6.8 Set % Step for Rate Offset

This sets the amount by which the rate is adjusted away from the target rate when you press the  or  buttons.

1. Press and hold the  button as you switch the instrument on. The instrument is then in programme mode 3 on channel 1 (fig. 17).
2. Press  to select channel 3. The display will show a number indicating the % step (5 - 25% in 5% increments) (fig. 20).
3. PRESS  to select the required % step.
4. Switch off and on again resume normal operating mode.

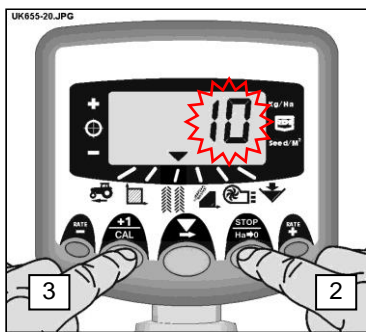

Figure 20: Set % Rate Step



## 7. Fan Display

### 7.1 View Fan Status



This channel simply indicates whether the fan is 'ON' or 'OFF'.

### 7.2 Fan Status Alarm

When the Multi-Seeder is in work and the fans are not switched on, the instrument will default to the fan status channel, beep 5 times and flashes 'Fan' 'OFF'.

When the Multi-Seeder is in work with the fan switch on, but the fan is not running, the instrument will default to the fan status channel, beep 5 times and flashes 'OFF' 'FAIL'.

NOTE: If the Fan Status Alarm 'OFF' - 'FAIL' appears but the fans are still running OK, the fan fail alarm function can be disabled in Cal Mode 2 - Channel 5, by setting the fan alarm option to "On B" (ref. Section 9).

## 8. Hopper level Alarm



When the hopper level sensor is uncovered, the instrument will default to the hopper level channel (  ) beeps 5 times and flashes 'ALAr' every 30 seconds.

The alarm may be cancelled temporarily by selecting another channel but will revert to the hopper level display and repeat the alarm after 30 seconds.

### 8.1 Feed roll monitoring

If the feed roll stops during operation (e.g. the chain between the motor and the feed roll is breaking), the hopper level alarm will be activated too.

## 9. Programme Functions and Fault Diagnosis

### 9.1 Programme Modes 1 – 5

Some settings do not need to be accessed during normal operation, unless the system is transferred to another implement.

Those settings that need to be accessed during normal operation are explained in the operators' section (sections 3 - 8) of the manual.

	Mode 1	Mode 2	Mode 3 (Product calibration)	Mode 4	Mode 5
<b>Mode Entry</b>	From normal display mode, select channel and hold +1/CAL button continuously	Press and hold +1/CAL button for 10 seconds while switching instrument on	Press and hold STOP/HA-0 button while switching instrument on	Press and hold RATE+ button for 10 seconds while switching instrument on	Press and hold RATE- button for 10 seconds while switching instrument on
<b>Channel selection</b>	-	Press +1/CAL button	Press STOP/HA-0 button	Press RATE+ button	Press RATE- button
<b>Channel 1</b>	Speed Sensor Factor [7.78 mm/pulse] (see section 4.3)	Simulated Speed [10 km/h]	Unit Selection [kg/ha] (see section 6.7)	Pulses/metering unit rev. [600]	Cut Out Alarm Speed [2.00 km/hr]
<b>Channel 2</b>	Implement Width [4.0 m] (see section 5.3)	Grand Total Area [ha]	T.G.W. [45.00 g] (see section 6.6)	Response [1000]	Shaft Conf [Hop]
<b>Channel 3</b>	N/A	N/A	Rate - % Step [5%] (see section 6.8)	-----	
<b>Channel 4</b>	Seed calibration factor [0.01 kg/rev]	Motor Stall Status On/Off [On]	Expected Weight (0-9999 grams) (see section 6.5)	Motor Calibration Speed [35 rpm]	
<b>Channel 5</b>	-----	Fan Alarm Status Fan On A/ On B/ Off [On A]	Minimum Fwd speed (see section 6.5)	Startup PWM [20 %]	
<b>Channel 6</b>	Hopper Level Alarm On / Off [On]	Pre-start time [4 seconds]	Calibration complete (see section 6.5)	Minimum Metering Speed [3 rpm]	

## 9.2 Fault Diagnosis

Condition	Possible reasons
When in work and moving the Instrument displays ' <b>C.out</b> ' and beeps every 5 seconds	The forward speed is above 2km/h while the Multi-Seeder is out of work.  The cutout switch is not operating correctly when the implement is lifted or lowered.
When in work the instrument defaults to the fan status channel, displays ' <b>OFF</b> ' and beeps every 30 seconds	You forgot to switch the fans on at the hand controller.  The fans remain switched off. Check that the 'FAN' switch on the HE-VA Auto-Controller junction box is on.
When in work the instrument defaults to the fan status channel, and the display alternates between ' <b>OFF</b> ' and ' <b>Fail</b> ', and beeps every 30 seconds.	There is a fault with one or both the fan drive. Check the wiring connections.
When in work the instrument flashes ' <b>ALAr</b> ' and beeps.	Hopper level is low.
When in work the instrument defaults to the rate channel, displays ' <b>Fail</b> ' and beeps every 30 seconds. The metering roll does not turn.	The metering motor is not working. It is automatically stopped.  Switch the instrument off and back on to clear the fault. Check the wiring connections and try again.
When in work the instrument defaults to the rate channel, displays ' <b>StAl</b> ' and beeps every 30 seconds. The metering roll does not turn.	The metering motor has stalled. It is automatically stopped to prevent further damage.  Investigate.
When in work the instrument defaults to the application rate channel, flashes a rate lower than the target and beeps continuously.	The application rate is low because the forward speed is too high and the target motor speed cannot be achieved. Reduce your speed or change the metering roll and recalibrate.
When in work the instrument defaults to the forward speed channel, the speed display flashes and beeps continuously.	Forward speed is too low. The metering roll is at its minimum possible rpm. Increase your speed, or if this would too fast, change the metering roll and recalibrate.
	<i>If you find that the minimum forward speed is too high at low application rates you should change the feed roll to a lower volume roll and redo the product calibration.</i>



# 11. Spare part list

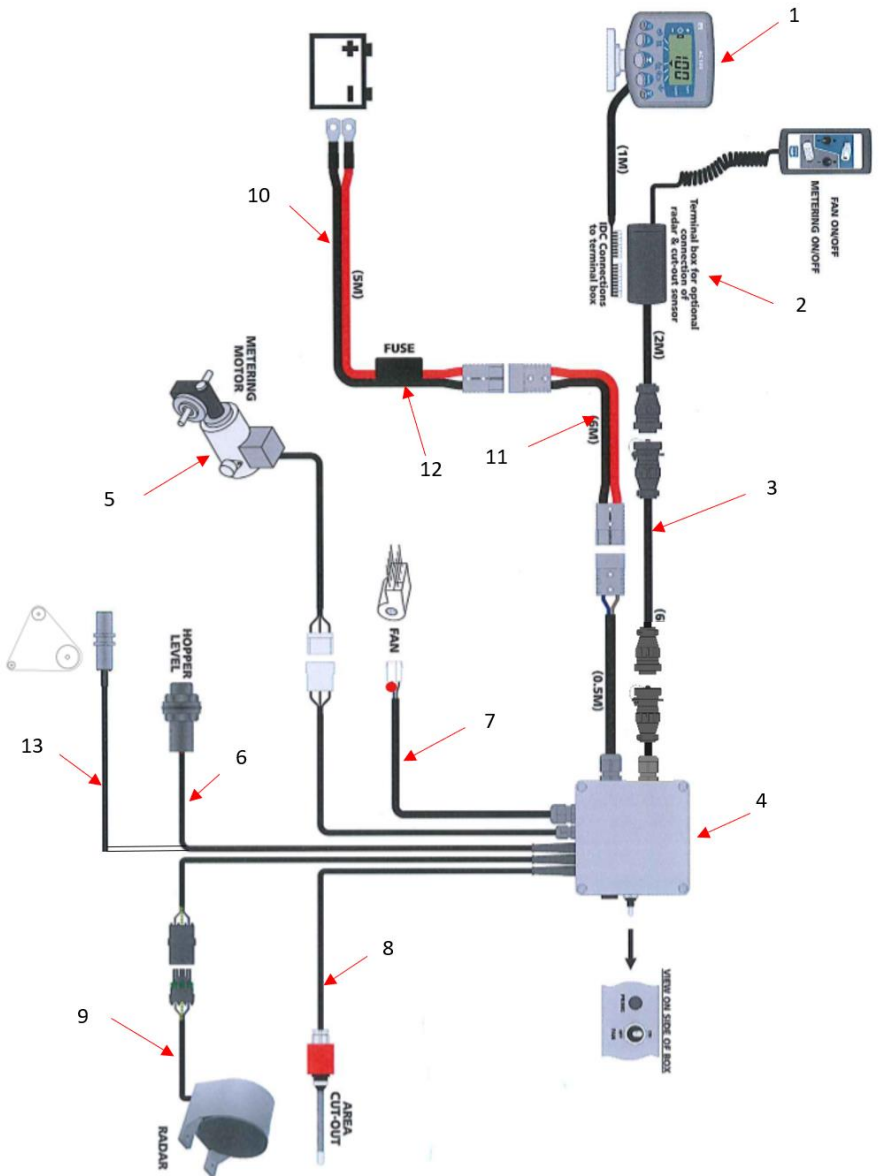

---

<b>Pos.</b>	<b>Item no.</b>	<b>Designation</b>
1	0520486	Monitor (Plus)
2	0520495	Tractor terminator
3	0520466	Extension cable 4m
	0520467	Extension cable 6m
	0520468	Extension cable 10m
4	0520580	Junction box Plus
4a	0520581	PCB for 0520580
5	0520474	Motor
6	332052778	Sensor f/tank capacity
7	0539042	Fan (el)
8	0520464	Switch RDS
9	0520462	Radar
10	0520476	Cable incl 40A fuse
11	0520469	Extension cable 4m
	0520470	Extension cable 6m
12	0525900	Fuse 40A (standard)
13	302052777	Sensor f/metering roller



