

UK

HE-VA

Operating Instructions
Spare Parts List
Declaration of Conformity

as it looks



As good as it looks



As good as it looks

As good as it looks



As good as it looks

Warning: Be sure to read the operation instructions before using the machine.

Top-Cutter Solo

Single/Twin: 3,0 m - 6,0 m

Manual no. 8000421-01 010421

 **HE-VA**

N. A. Christensensvej 34
DK-7900 Nykøbing Mors
Tel: 97724288
Fax: 97722112
www.he-va.com

Contents

EC DECLARATION OF CONFORMITY	3
Delivery Check	4
Machine description	4
Technical specifications	4
Working with the Top-Cutter Solo	5
Safety around the Top-Cutter Solo	6
Safety Instructions, regarding Hydraulic System	7
Markings on the machine	8
Maintenance	9
Disposal.....	9
Spare Parts List	10
Rigid Single model 3,0 - 4,0m	10
Singel modeller 4,0 - 5,0 - 6,0m complete machine	12
Middle section Single 4,0 - 5,0 - 6,0m.....	13
Ving section Single 4,0 - 5,0 - 6,0m	14
Twin models 4,0 - 5,0 - 6,0m complete machine.....	15
Middle section Twin 4,0 - 5,0 - 6,0m.....	16
Wing section left Twin 4,0 - 5,0 - 6,0m.....	17
Carrier arm for roller.....	18
Knife overview.....	19
Support leg	20
Overview additonal equipment Twin 4,0 - 5,0 - 6,0m.....	21
Weight plates with assembly parts.....	22
Material damper guard Single/Twin models.....	23
For rigid model.....	23
LED – light.....	24
Notes	25
Hydraulic.....	26
All hydraulic models.....	26



EC DECLARATION OF CONFORMITY

in accordance with the EU Machinery Directive 2006/42/EC
applicable as from December 29th 2009:

HE-VA ApS
N. A. Christensensvej 34,
DK-7900 Nykøbing Mors

hereby confirms that the following machine has been manufactured in accordance with the Council
Directive 2006/42/EC.

The declaration comprises the following machines:

Top-Cutter Solo
3,0m – 3,5m rigid
4,0m – 6,0m hydraulic foldable

A handwritten signature in blue ink, appearing to read 'Villy Christiansen', with a horizontal line extending to the right.

Nykøbing the 28th february 2021 Villy Christiansen

The undersigned is furthermore authorised to compile technical documentation for the above
machine.

Delivery Check

Check the Top-Cutter for any damage when it is received at either the dealer and the final customer. Check that the frame construction has not been exposed to impacts. Check the hydraulic hoses, at hydraulic models, for cuts and squeezing damages. Check also the other hydraulic components, are not damaged during transport.

Machine description

The Top-Cutter is either a rigid or a hydraulic foldable model as a 3-section construction. The machine can be delivered as a Single or Twin model roller. When Twin roller model the knives are mirrored between front and rear roller, to make a cross pattern at the surface. The machine is delivered as a front mounted model, and as accessories an A-frame for rear mounting is available.

Additional equipment:

- A-frame for rear mounting at either rigid or hydraulic models
- Weight plates of 30 kg each. Maximum of 3 pc per meter working width
- LED-marker light
- LED-lights for rear mounted models
- 2 pc. of reflex boards
- Material damper Guard

Technical specifications

Working width	Type	Single/Twin	Transport width	Weight kg
3,0m	Rigid	Single	3030	700
		Twin	3030	990
3,5m	Rigid	Single	3490	780
		Twin	3490	1.043
4,0m	Rigid	Single	4020	890
		Twin	4020	1.180
	Hydraulic	Single	2750	1.250
		Twin	2750	1.620
5,0m	Hydraulic	Single	2750	1.360
		Twin	2750	1.810
6,0m	Hydraulic	Single	2750	1.650
		Twin	2750	2.050



Oil pressure	Minimum 170 bar
Hydraulic outlets	1 double acting
Quick couplings, standard	Sterling type E 402
Hydraulic oil: The machine is filled with	Hydro Texaco HD32

Working with the Top-Cutter Solo

The area must be dry and firm to achieve the best result. Drive around wet spots where the machine sinks and works unintentionally.

If the shape of the field allows it, it is recommended to try to drive with, for example, a 20° - 35 ° angle on the direction of travel to achieve a better effect.

The speed to be driven should be between 10 - 18 km / h. For solid stones, the speed must be reduced and possibly lift the machine.

Avoid driving over deep tracks in the field that are perpendicular to the direction of travel, with the Top-Cutter lowered.

On hydraulic models, the ball valves on the folding cylinders must always be closed when the machine is in the transport position.

The tractor's lift arms **must always** be in the float position while driving. Do not transfer weight from the tractor to the Top-Cutter.

The machine support legs **must always** be used when the machine is disconnected. The machine can stand without support legs but is unstable and can tip over with a slight impact.

Important: When the machine is unfolded, the oil pressure in working position on the machine's manometer must not exceed 60 - 80 bar.

The 3 parts of the machine must be able to move independently of each other while driving. If the machine becomes completely stiff, the pressure must be reduced.



Safety around the Top-Cutter Solo

Do not operate the machine, if any **people**¹ are at risk in the **dangerous area**.²

When persons are at risk in the dangerous area (e.g. when doing adjustments, maintenance or connect or disconnecting), the following points must be met:

- Lower the machine on solid ground.
- Hydraulics must be relieved.
- Tractor must be turned off, and the key removed.
- Driver must be aware, when operating that there is no persons at risk in the dangerous area.
- When replacing knives, it is not aloud to work underneath the machine without any rigid support which are approved for the purpose. As an alternative the machine can be tilt around to stand on the A-frame and fixed in this position.

Most accidents when operating the machine, transporting and doing maintenance occurs, when avoiding the most simple safety regulations.

For this reason, it is of highest importance, that any person who is operating the machine, strictly follows the safety regulations and other instructions, which belongs the machine.

The machine must only be operated, maintained and fixed by persons, who is confident with and skilled for this work and is aware of moments of danger, which can occur.

ATTENTION!! Rotating parts and clothes in a loose condition, is a dangerous combination.

IMPORTANT!! It is strictly prohibited for any person to stand on the frame or chassis of the machine, when it is either operating or the tractor is idling.

Instructions for transport on public roads:

Before transport on public roads, make sure that the attachment of the implement to the tractor, is in accordance with the local rules and regulations in force (permitted total weight, permitted axle load, transport width, lights and warning signs).

Front axle load:

When the implement is attached and at maximum load, the tractors driving properties must be ensured. Check that the front axle is sufficiently loaded. The front axle load must be at least 20% of the tractors weight. Permitted axle load and total weight for the tractor must be respected.

NB! The driving, controlling and braking properties are affected by the attached implement.

¹ People at risk: Any person, who is completely or partially in the dangerous area.

² Dangerous area: At the machine and underneath it, and in a distance of 4 m from it.

Safety Instructions, regarding Hydraulic System

- The highest allowable pressure, is 225 bar.
- It is recommended to mark the hydraulic connections between the implement and tractor, to avoid incorrect operation!
- When checking for hydraulic leaks, suitable safety gear must be used due to danger. (Safety, goggles, gloves, etc.)
At high pressure, hydraulic oil can penetrate the skin and cause serious injuries.
- Before any work at the hydraulic system, the implement must be lowered to solid ground. Pressure must be relieved, engine stopped, and ignition key removed.
- Check the hydraulic hoses on a regular basis, however, every six months as a minimum due to any cracks, wear and tear, etc. Replace any defective hoses immediately.
- Hydraulic hoses lasts for no more than 5 years.
New hydraulic hoses must be identical to the manufacturers specifications.



Markings on the machine

Several markings are located on your machine, which contains **safety regulations** and other instructions to inform about correct operating.

Please read these instructions carefully, and make the driver aware about the markings and **safety regulations** in this Operating Instructions. Keep the markings clean and readable. If they are not, they must be replaced.

Safety and other markings on the machine



Study the Operating Instructions thoroughly before any operation of the machine and observe all safety instructions.



Plate with number and year of manufacture.



Warning instruction

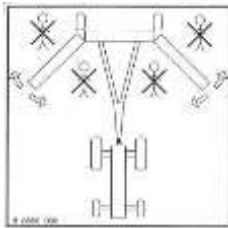

Take care that no persons are within the machine's hazardous area during the unfolding and folding procedure.



Maintenance

After 10 hours of operation, tightening of wheels, bearings and stop rings must be done. If this is not respected our warranty will lapse.

Maximum torque in Nm. w/lubricated thread			
Metric thread	Quality 8.8	Quality 10.9	Quality 12.9
M10x1,5	47	65	79
M12x1,75	81	114	136
M14x2,0	128	181	217
M16x2,0	197	277	333
M18x2,5	275	386	463
M20x2,5	385	541	649
M22x2,5	518	728	874
M24x3,0	665	935	1120
Hub bolts M18x1,5 fine thread		433 Nm	
Hub bolts M22x1,5 fine thread		803 Nm	

Eventually damages at the paint must be repaired at least once in the season. This will preserve and make the machine stay in a good condition for many years.

- On foldable models the cylinder bushings and hinge joints must be greased at every 20 hour of operating
- Bearings at the rollers twice a year and after every machine wash.

Disposal

When, after many years of use, the machine is to be regarded as end-of-life, it must be disposed of to a registered and approved product dealer. This will carry out the statutory discharge and disposal of hydraulic oil, as well as sorting materials for further processing for recycling.



Spare Parts List

Rigid Single model 3,0 - 4,0m

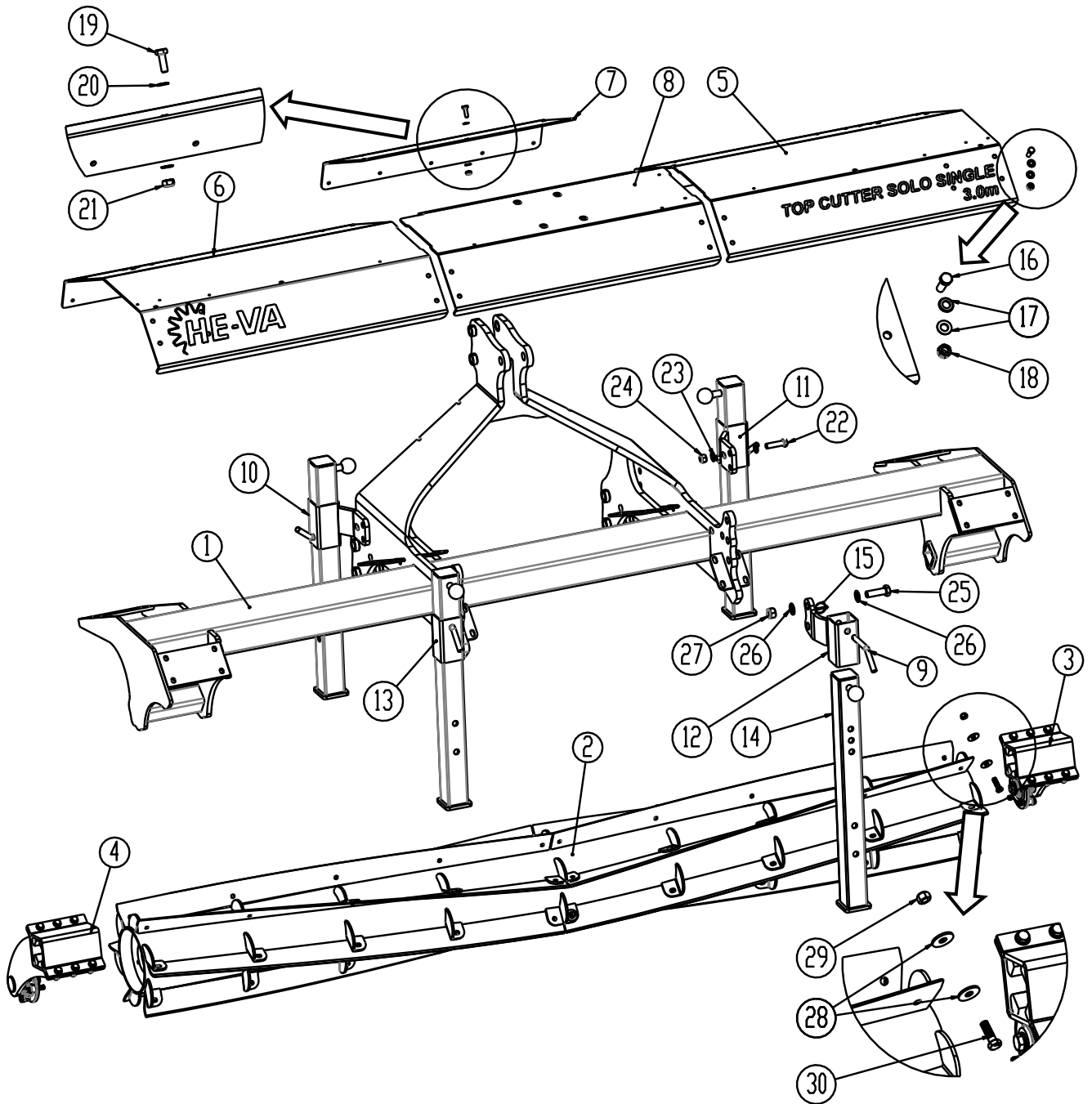

Pos.	Part no.	Description	3,0m	4,0m
1	1330881	Main frame 3,0m	1	
1		Main frame 4,0m		1
2	7455000	Top-Cutter rotor L=2930 with knives	1	
2		Top-Cutter rotor L= with knives		1
3	1330243	Carrier arm left	1	1
4	1330242	Carrier arm right	1	1
5	1330884	Shield left	1	
5		Shield left		1
6	1330885	Shield right	1	
6		Shield right		1
7	1330312	Shield middle rear	1	
7		Shield middle rear		1
8	1330854	Shield middle front	1	
8		Shield middle front		1
9	69516094A	Pin Ø16 L=94	4	4
10	1330604	Bracket for support leg, right front	1	1
11	1330605	Bracket for support leg, left rear	1	1
12	1330747	Bracket for support leg, left front	1	1
13	1330743	Bracket for support leg, right rear	1	1
14	1330611	Support leg complete, for parts see further below	4	4
15	0378200	Ring pin	4	4
16	0235350	Bolt M12x35 8.8 fzb	28	
17	0272270	Facet washer Ø12 fzb DIN125B	56	
18	0264070	Self-locking nut M12 fzb DIN985	28	
19	0235050	Set bolt M10x30 8.8 fzb	5	
20	02742260	Facet washer Ø10 fzb DIN125B	10	
21	0264060	Self-locking nut M10 fzb DIN985	5	
22	0235840	Bolt M16x60 8.8	6	
23	0272290	Facetskive Ø16 DIN125B	12	
24	0264090	Self-locking nut M16 fzb DIN985	6	
25	0236140	Bolt M20x65 8.8 DIN931	4	
26	0272310	Facetskive Ø20 DIN125B	8	
27	0264110	Self-locking nut M20 fzb DIN985	4	
28	0272620	Washer Ø13,0 x Ø37 x 3,0 DIN980	108	
29	690113019	Steel self-locking nut M12 DIN980	54	
30	0235369	Bolt M12x40 10.9	54	

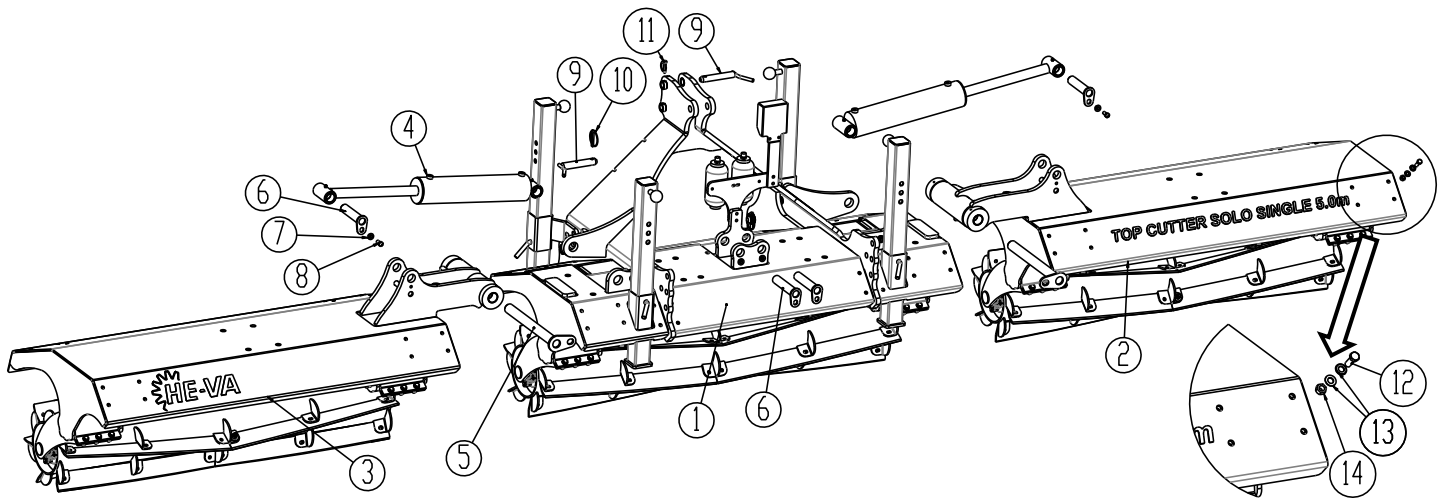

Singel modeller 4,0 - 5,0 - 6,0m complete machine

Pos.	Part no.	Description	4,0m	5,0m	6,0m
1	1330661	Middle section with A-frame	1	1	1
2	1330868	Side section left	1		
2	1330665	Side section left		1	
2		Side section left			1
3	1330859	Side section right	1		
3	1330663	Side section right		1	
3		Side section right			1
4	7345175	Cylinder 100/40 x 400 ϕ 35/35	2	2	2
5	69440415N	Pin ϕ 40 L=415	2	2	2
6	69435155G	Pin ϕ 35 L=155	4	4	4
7	630532600	Lock bushing for pin head	6	6	6
8	0235350	Bolt M12x35	6	6	6
9	69528129B	Pin ϕ 28	3	3	3
10	690134008	Ring clip ϕ 11,5 ϕ 60 ring	2	2	2
11	690134004	Ring clip ϕ 10	1	1	1
12	0235350	Bolt M12x35 8.8 fzb	70	72	
13	0272270	Facet washer ϕ 12 fzb DIN125B	140	144	
14	0264070	Self-locking nut M12 fzb DIN985	70	72	

Notice: When ordering new knives, see page 21 - 22

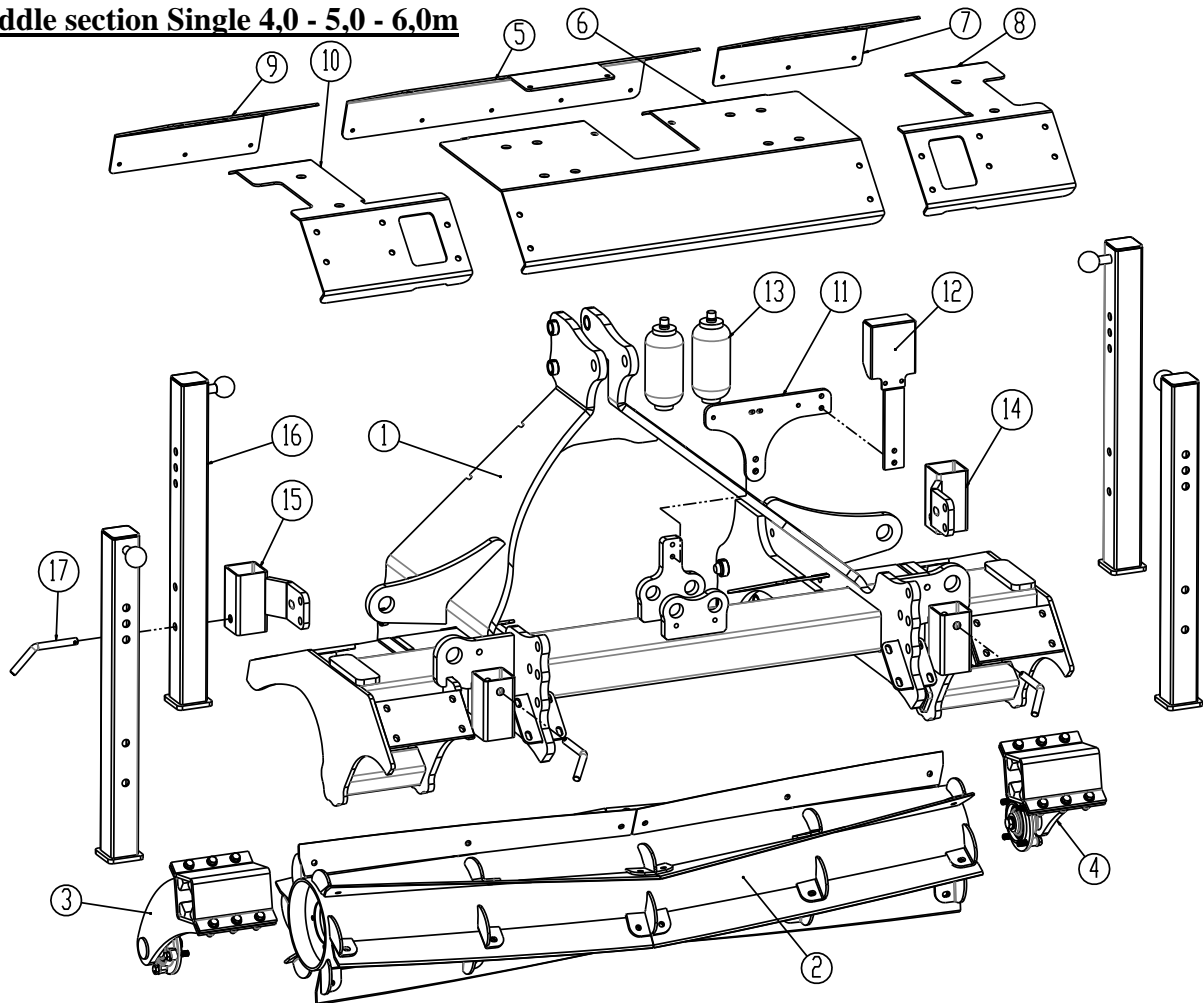

Middle section Single 4,0 - 5,0 - 6,0m

Pos.	Part no.	Description	Qty
1	1330662	Middle frame	1
2	7455120	Top-Cutter rotor L = 1670 mm	1
3	1330242	Carrier arm right	2
4	1330243	Carrier arm left	2
5	1330435	Screen middle rear	1
6	1330688	Screen middle front	1
7	1330691	Screen left rear	1
8	1330689	Screen left front	1
9	1330693	Screen right rear	1
10	1330692	Screen right front	1
11	1330467	Holder for accumulators and manometer	1
12	630941066	Housing for manometer	1
13	690206410	Accumulator H700R 40 bar	1
14	1330605	Bracket for support leg left rear	4
15	1330604	Bracket for support leg right rear	1
16	1330611	Support leg complete	4
17	69516094A	Pin \varnothing 16 L=94	4

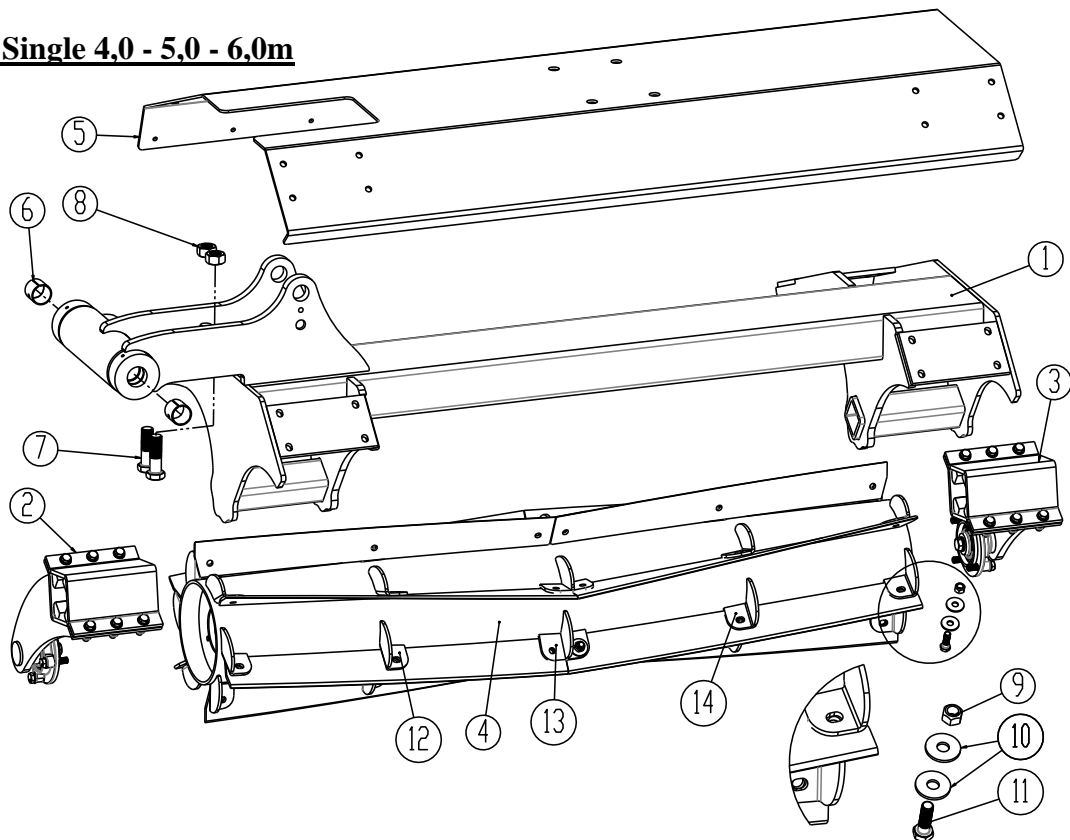

Ving section Single 4,0 - 5,0 - 6,0m

Pos.	Part no.	Description	4,0	5,0	6,0
1	1330867	Wing left	1		
1	1330666	Wing left		1	
1		Wing left			1
1	1330858	Wing right	1		
1	1330664	Wing right		1	
1		Wing right			1
2	1330242	Carrier arm right	4	4	4
3	1330243	Carrier arm left	4	4	4
4	7455125	Top-Cutter rotor L = 1060 mm	2		
4	7455072	Top-Cutter rotor L = 1560 mm		2	
4		Top-Cutter rotor L = mm			2
5	1330866	Screen left	1		
5	1330621	Screen left		1	
5		Screen left			1
5	1330870	Screen right	1		
5	1330624	Screen right		1	
5		Screen right			1
6	0475100	Sleeve bearing Ø40/Ø44 L=40	4	4	4
7	0236390	Bolt M24x80 8.8 fzb	4	4	4
8	0261425	Nut M24 galvanized	4	4	4
9	690113019	Steel self-locking nut M12 DIN980	108	108	
10	0272620	Plain washer Ø13,0 x Ø37 x 3,0 DIN980	216	216	
11	0235369	Bolt M12x40 10.9	108	108	

The tabel continues →



12	7455007	Knife bracket left, mounted by welding			
13	7455010 7455011	Knife bracket middle, mounted by welding (Made out of 2 parts)			
14	7455009	Knife bracket right, mounted by welding			

Twin models 4,0 - 5,0 - 6,0m complete machine

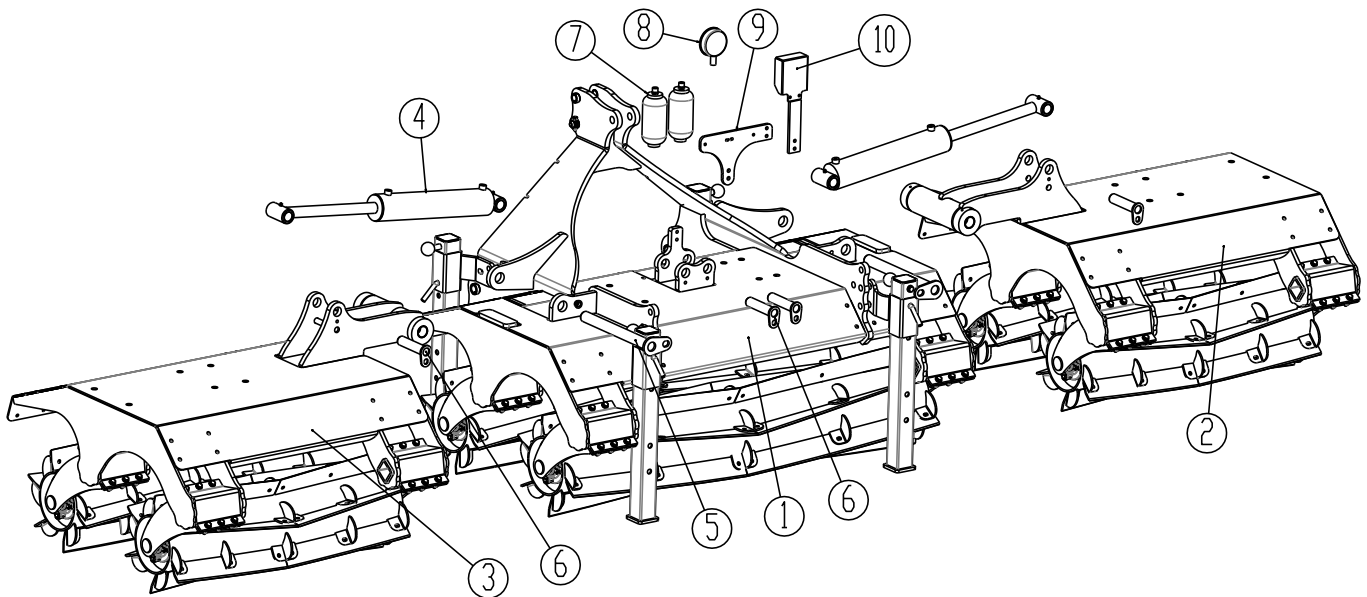

Pos.	Part no.	Description	4,0m	5,0m	6,0m
1	1330660	Middle section with 3-point linkage	1	1	1
2	1330655	Left side section	1		
2	1330656	Left side section		1	
2	1330658	Left side section			1
3	1330653	Right side section	1		
3	1330657	Right side section		1	
3	1330659	Right side section			1
4	7345175	Cylinder 100/40 x 400 ϕ 35/35	2	2	2
5	69440415N	Pin ϕ 40 L=415	2	2	2
6	69435155G	Pin ϕ 35 L=155	4	4	4
7	690206410	Accumulator H700R 40 bar	2	2	2
8	0442052	Manometer	1	1	1
9	1330467	Holder for accumulators and manometer	1	1	1
10	630941066	Housing for manometer	1	1	1

Notice: When ordering new knives, see page 21 - 22

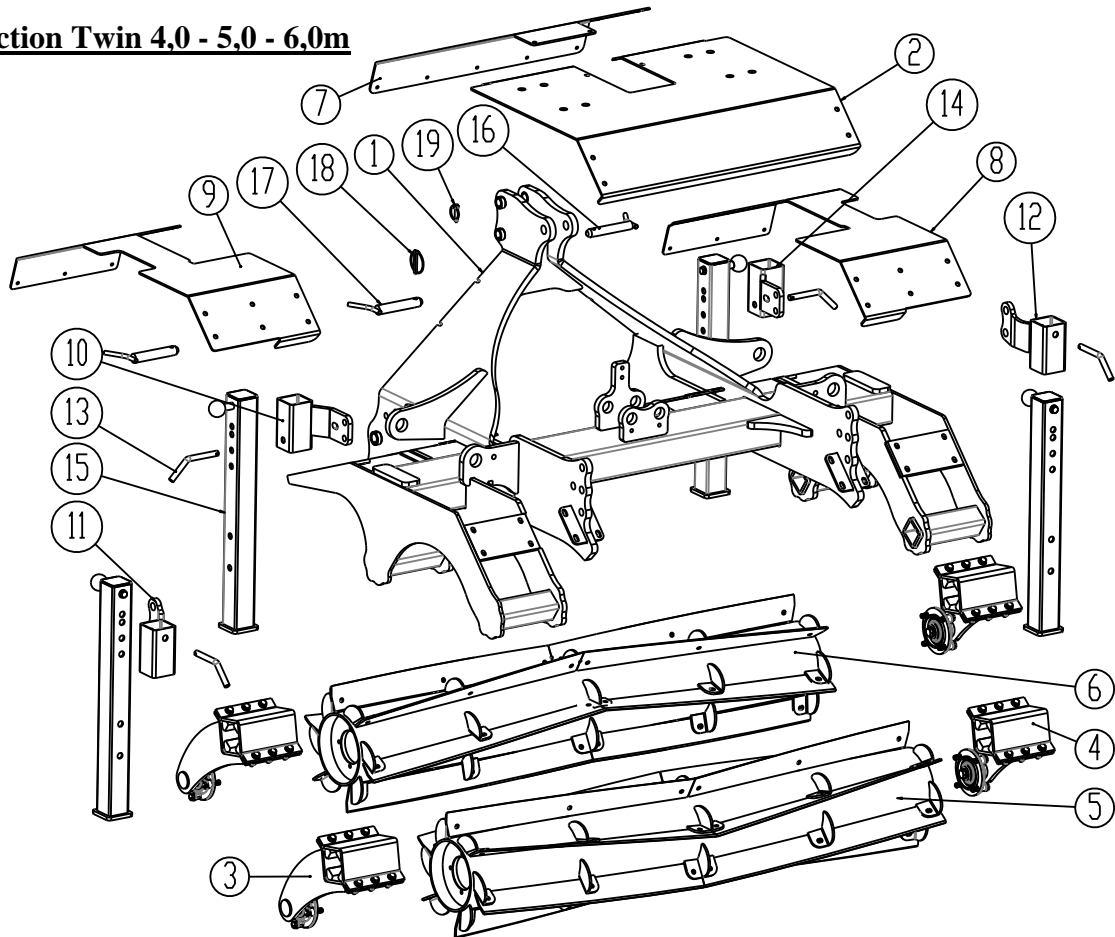

Middle section Twin 4,0 - 5,0 - 6,0m

Pos.	Part no.	Description	Qty.
1	1330640	Middle frame	1
2	1330703	Middle screen front	1
3	1330242	Carrier arm right	2
4	1330243	Carrier arm left	2
5	7455120	Top-Cutter roller L = 1670 mm front	1
6	7455132	Top-Cutter roller L = 1670 mm rear	1
7	1330435	Middle screen heck	1
8	1330704	Screen left	1
9	1330705	Screen right	1
10	1330604	Bracket for support leg right rear	1
11	1330743	Bracket for support leg right front	1
12	1330747	Bracket for support leg left front	1
13	69516094A	Pin L=94	4
14	1330605	Bracket for support leg left rear	1
15	1330611	Support leg complete	4
16	69525129B	Pin Ø25 L=129	1
17	69528129B	Pin Ø28 L=129	2
18	690134008	Ring pin Ø11,5	2
19	0378600	Ring pin Ø10	1

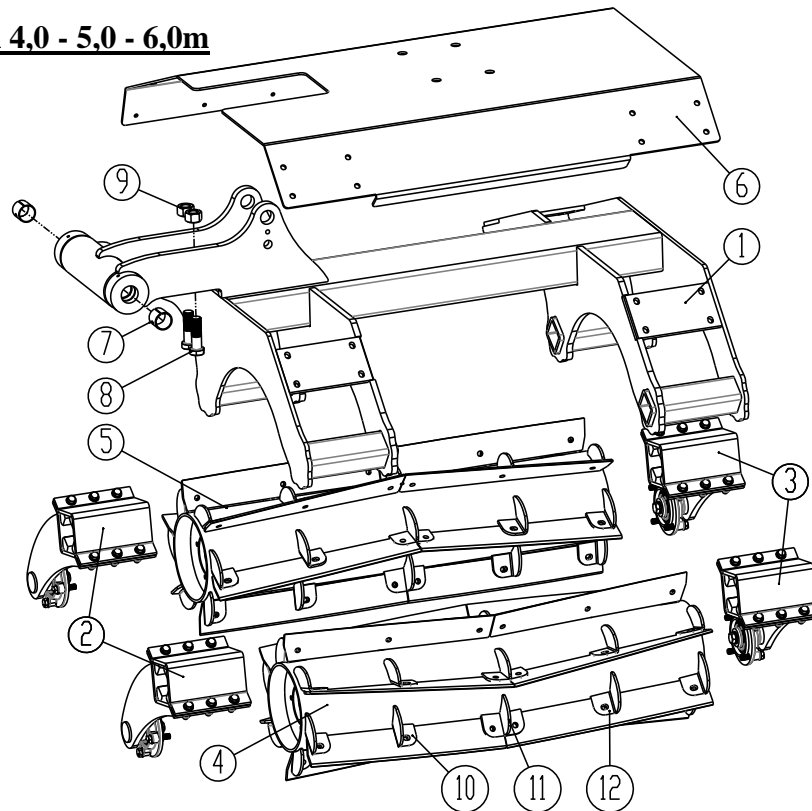

Wing section left Twin 4,0 - 5,0 - 6,0m

Pos.	Part no.	Description	4,0	5,0	6,0
1	1330651	Wing left	1		
1	1330649	Wing left		1	
1	1330647	Wing left			1
1	1330650	Wing right	1		
1	1330648	Wing right		1	
1	1330643	Wing right			1
2	1330242	Carrier arm right	4	4	4
3	1330243	Carrier arm left	4	4	4
4	7455125	Top-Cutter roller L = 1060 mm Front	2		
4	7455072	Top-Cutter roller L = 1560 mm Front		2	
4	7455145	Top-Cutter roller L = 2060 mm Front			2
5	7455140	Top-Cutter roller L = 1060 mm Rear	2		
5	7455157	Top-Cutter roller L = 1560 mm Rear		2	
5	7455151	Top-Cutter roller L = 2060 mm Rear			2
6	1330463	Screen left	1		
6	1330578	Screen left		1	
6	1330471	Screen 2-divided left inner			1
6	1330482	Screen 2-divided left outer			1
6	1330454	Screen right	1		
6	1330579	Screen right		1	
6	1330472	Screen 2-divided left inner			1
6	1330481	Screen 2-divided left outer			1



7	0475100	Bushing Ø40/Ø44 L=40	4	4	4
8	0236390	Bolt M24x80 8.8 fzb	4	4	4
9	0261425	Nut M24 galvanized	4	4	4
10	7455007	Knife bracket left, mounted by welding			
11	7455010 7455011	Knife bracket middle, mounted by welding (Made out of 2 parts)			
12	7455009	Knife bracket right, mounted by welding			

Carrier arm for roller

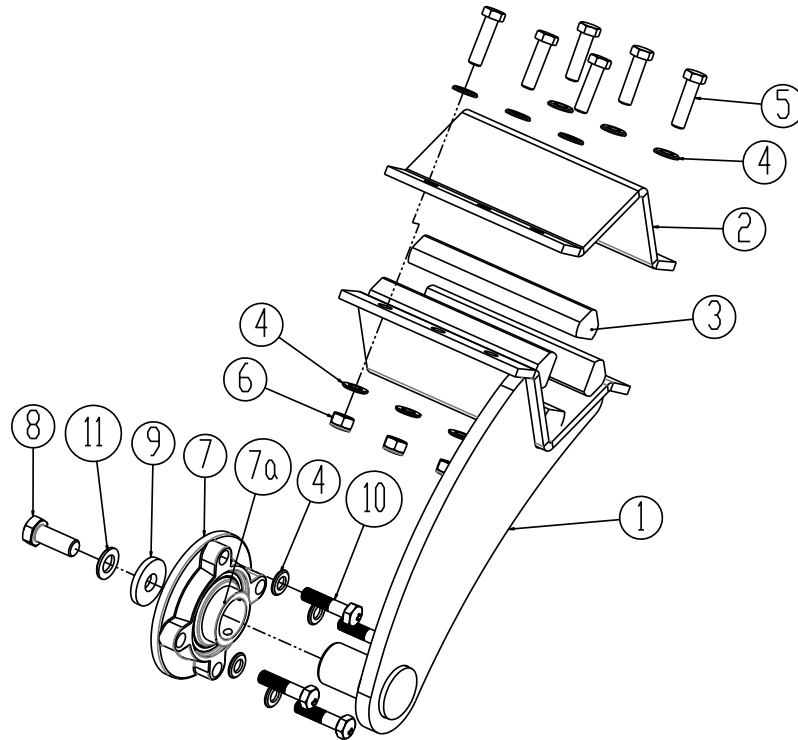

Pos.	Part no.	Description	Qty.
	1330242	Top-Cutter carrier arm right complete	
	1330243	Top-Cutter carrier arm left complete	
1	1330008	Carrier arm right	1
1	1330011	Carrier arm left	1
2	30949045	Mounting bracket for carrier arm	1
3	690210710	Rubber piece Ø35 L=190	4
4	0272270	Facet washer 12mm fzb DIN125B	16
5	690103091	Bolt M12x45 10,9	4
6	0264070	Self-locking nut M12 fzb DIN985	6
7	7355060	Bearing complete UCFC 208 R6	1
7a	7355061	Bearing UC 208 R6	1
8	0235790	Bolt M16x40 8.8	1
9	690117016	Hardened disc Ø17x45x6	1
10	0235380	Bolt M12x50 8.8 fzb	4
11	0272290	Facet washer Ø16 DIN125B	1

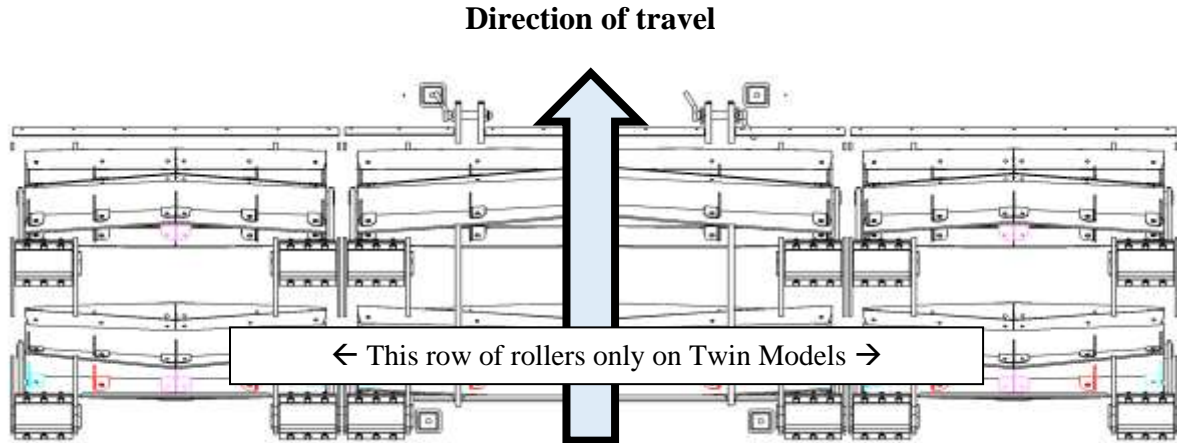

Knife overview

Single
4,0 m

7455128	7455127		7455123	7455122		7455128	7455127
---------	---------	--	---------	---------	--	---------	---------

5,0 m

7455074	7455073		7455123	7455122		7455074	7455073
---------	---------	--	---------	---------	--	---------	---------

6,0 m

7455148	7455147		7455123	7455122		7455148	7455147
---------	---------	--	---------	---------	--	---------	---------

Twin
4,0 m

7455128	7455127		7455123	7455122		7455128	7455127
7455142	7455141		7455138	7455133		7455142	7455141

5,0 m

7455074	7455073		7455123	7455122		7455074	7455073
7455159	7455158		7455138	7455133		7455159	7455158

6,0 m

7455148	7455147		7455123	7455122		7455148	7455147
7455153	7455152		7455138	7455133		7455153	7455152

Notice: When ordering, use the table below to check length and quantity

L = Length of blades in mm

Middle section on Single and Twin models		4,0m	5,0m	6,0m
7455122	Front right L = 838	6	6	6
7455123	Front left L = 838	6	6	6
7455133	Rear right L = 838 (Only Twin)	6	6	6
7455138	Rear left L = 838 (Only Twin)	6	6	6
Wings right and left on Single and Twin models		4,0m	5,0m	5,0m
7455127	Front right L = 531	12		
7455128	Front left L = 531	12		
7455141	Rear right L = 531 (Only Twin)	12		

The tabel continues →



7455142	Rear left L = 531 (Only Twin)	12		
7455073	Front right L = 780		12	
7455074	Front left L = 780		12	
7455158	Rear right L = 780 (Only Twin)		12	
7455159	Rear left L = 780 (Only Twin)		12	
7455147	Front right L = 1030			12
7455148	Front left L = 1030			12
7455152	Rear right L = 1030 (Only Twin)			12
7455153	Rear left L = 1030 (Only Twin)			12

Support leg

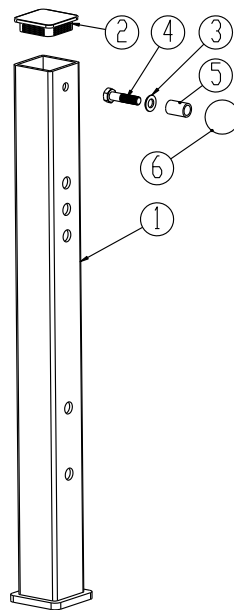

Pos.	Part no.	Description	Qty.
	1330611	Support leg complete, 4 pcs each machine	
1	1330608	Support leg	1
2	0489610	Plastic plug 70x70x5	1
3	0272270	Facet washer Ø12 fzb DIN125B	1
4	0235380	Bolt M12x50 8.8 fzb	1
5	110545-0	Bushing ø21,5/ø15 L=32	1
6	0489060	Plastic ball ø45 m/M12	1

Overview additional equipment Twin 4,0 - 5,0 - 6,0m

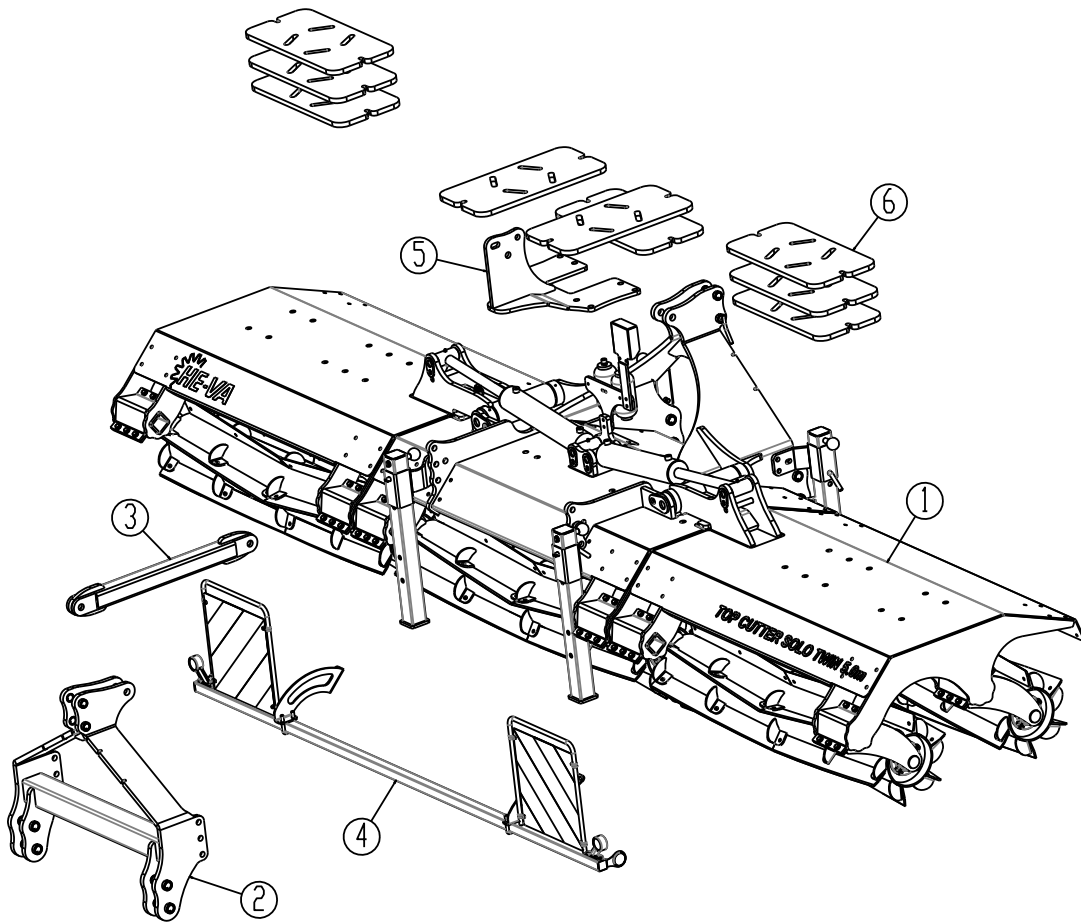

Pos.	Part no.	Description	Qty.
1		Basic machine	
2	1330676	3-point linkage for rear mounting	1
3	1330708	Toplink for 3-point linkage rear mounting	1
4	1330534	Light bar with marker lights and reflecters	1
5	1330406	Console for weight plates	1
6	1330718	Weight plates, max pcs. each meter workwidth are 3	9

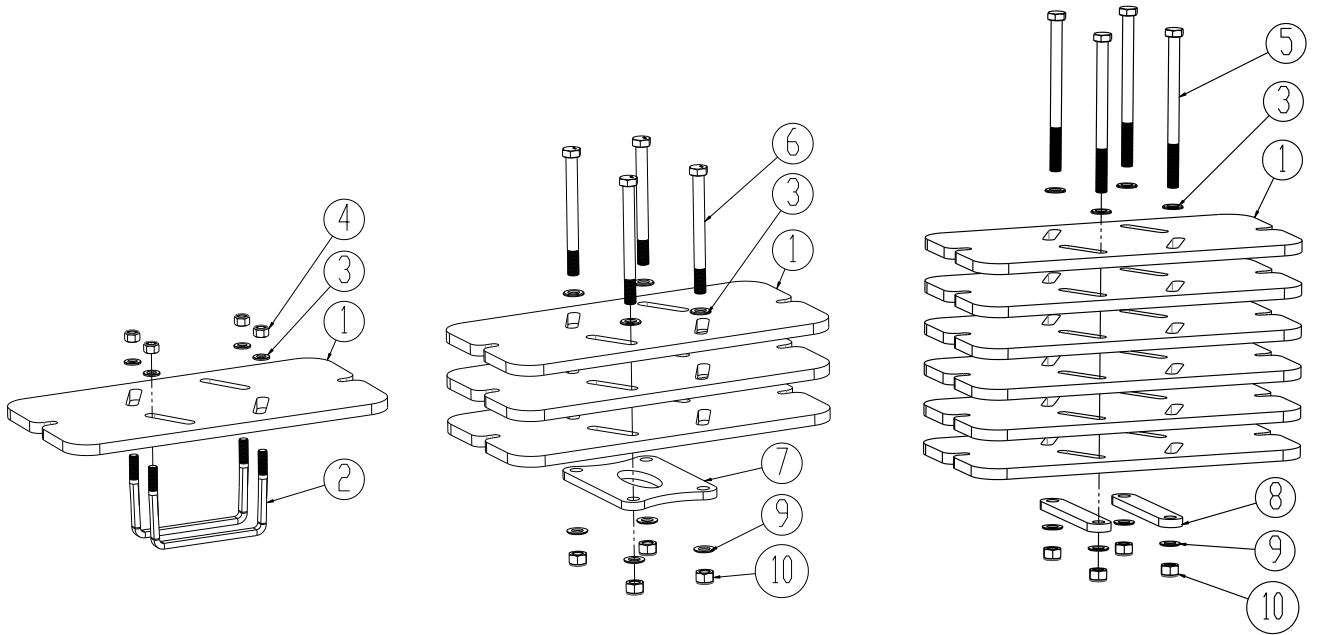

Weight plates with assembly parts

Pos.	Part no.	Description	Qty.
1	1330718	Weight plates, max pcs. each meter workwidth are 3	
2	0382852	U-bolt M16x100x200x100	2
3	0272290	Facet washer Ø16 DIN125B	4
4	0264090	Self-locking nut M16	4
5	0236315	Bolt M20x280 10.9	4
6	0236315	Bolt M20x220 10.9	4
7	1330758	Mounting flange	1
8	1330764	Mounting flange	2
9	0272310	Facet washer Ø20 DIN125B	4
10	0264110	Self-locking nut M20	4



Material damper guard Single/Twin models

For rigid model

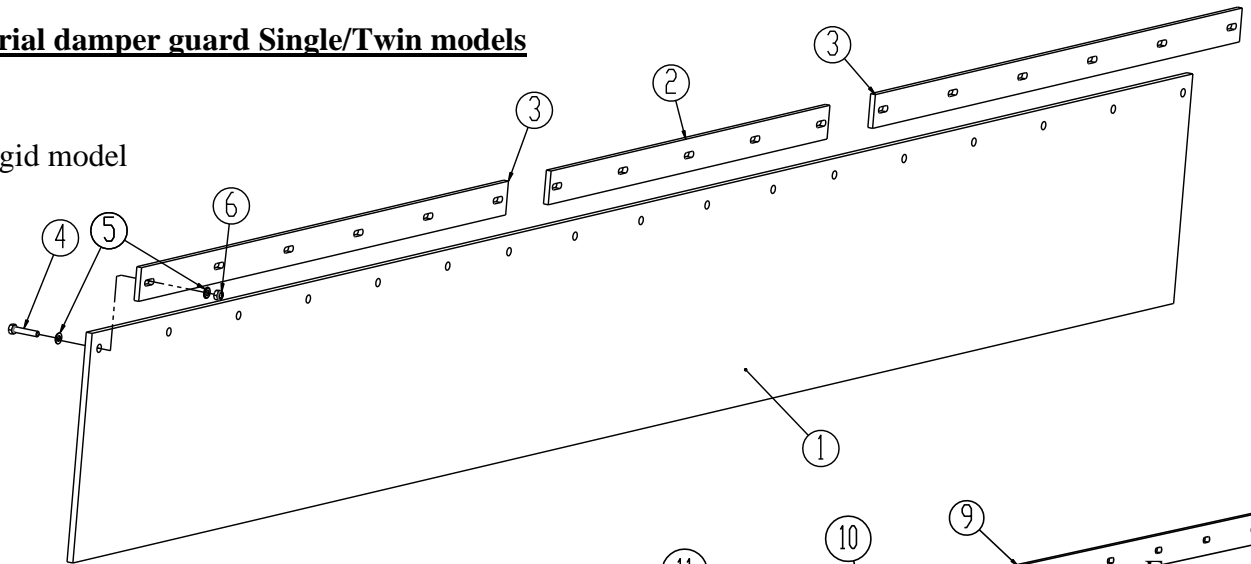

For hydraulic model

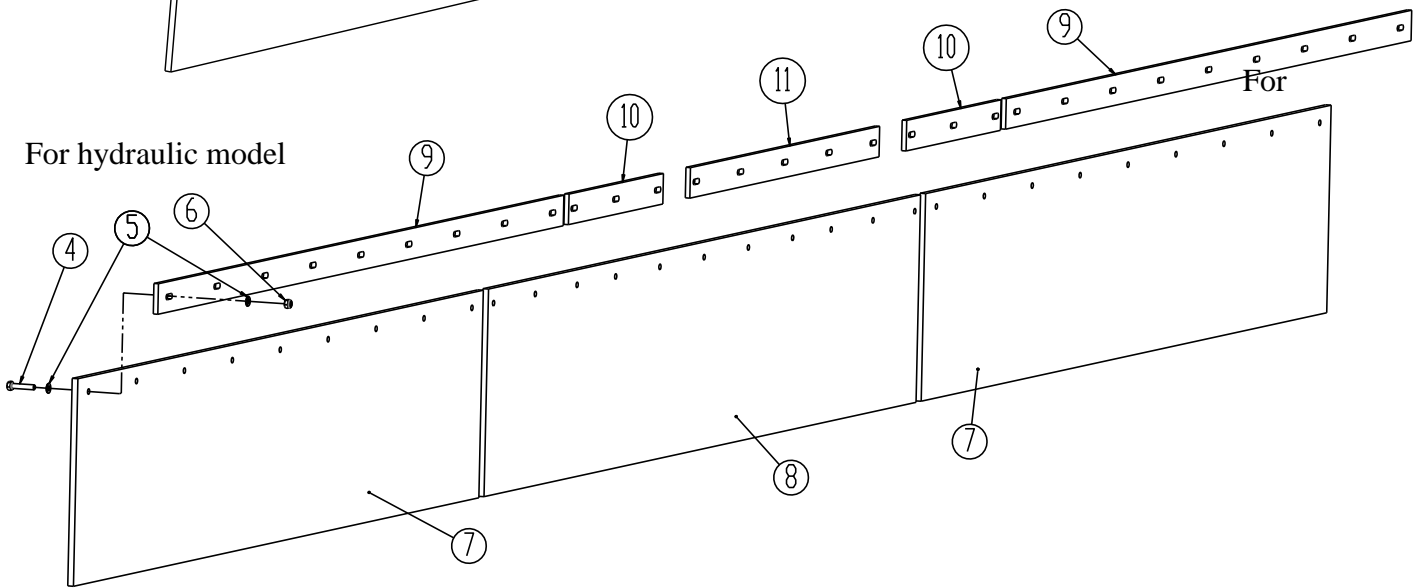

Pos.	Part no.	Description	3,0	4,0	5,0	6,0
1	1330559	Rubber plate 3000 mm	1			
2	1330760	Mounting bar 50x8 L=760	1			
3	1330759	Mounting bar 50x8 L=1000	2			
4	0434790	Bolt M8x40 fzb	17	25	29	35
5	0272250	Facet washer ø8 fzb	34	50	58	70
6	0264050	Self-locking nut M8 fzb	17	25	29	35
7	1330826	Rubber plate L=1148		2		
7	1330788	Rubber plate L=1650			2	
7	1330829	Rubber plate L=2148				2
8	1330795	Rubber plate 1758 mm		1	1	1
9	1330825	Mounting bar 50x8 L=1148		2		
9	1330789	Mounting bar 50x8 L=1650			2	
9	1330828	Mounting bar 50x8 L=1070				4
10	1330791	Mounting bar 50x8 L=384		2	2	2
11	1330790	Mounting bar 50x8 L=770		1	1	1



LED – light

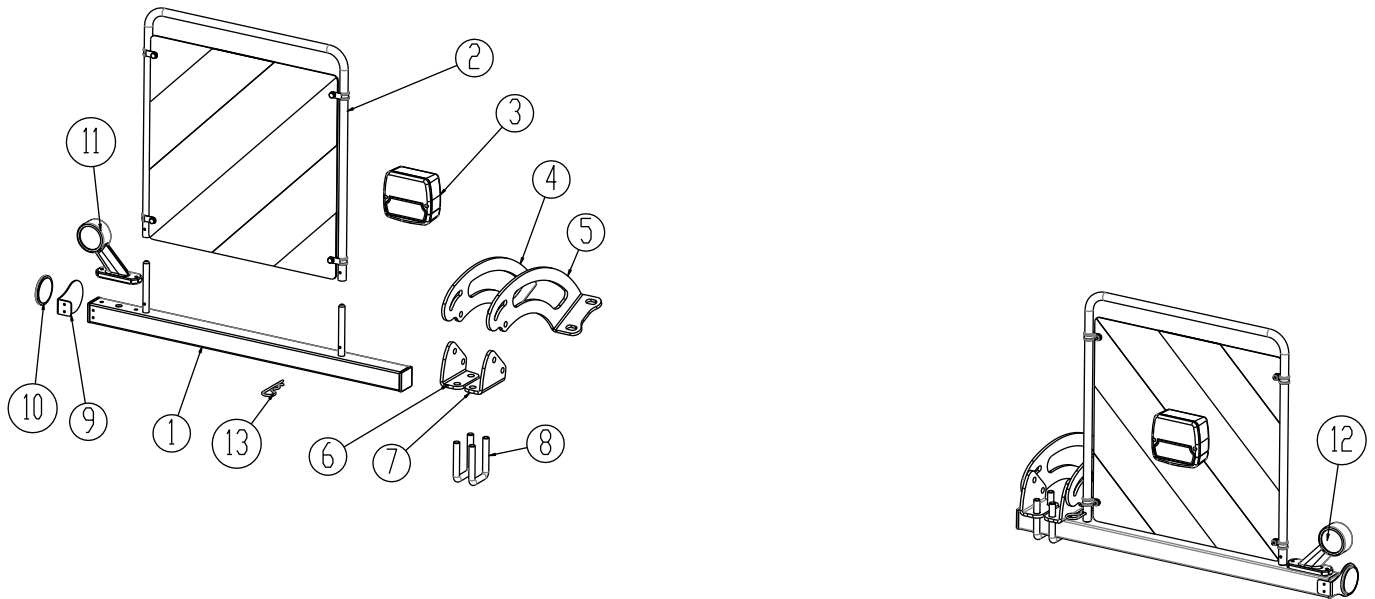

Pos.	Part no.	Description	Qty.
1	1330763	Light bar right/left	2
2	690160074	Reflector complete	2
3	7357504	Rear light complete	2
4	1330836	Bracket for light bar left	2
5	1330839	Bracket for light bar right	2
6	1330838	Bracket for light bar left	2
7	1330841	Bracket for light bar right	2
8	0382120	U-bolt M12 40x40x40	4
9	7357540	Holder for reflector	2
10	690160045	Reflector yellow	2
11	7357507	Marker light left	1
12	7357509	Marker light right	1
13	0377400	Hair pin	2

Notice: The ones shown are for rear-mounted machines. As front mounted, the light bars set are identical, but without pos. number 3

Notice: Check number and measurements of all cables before ordering the spare parts.



Notes

--	--



Hydraulic

All hydraulic models

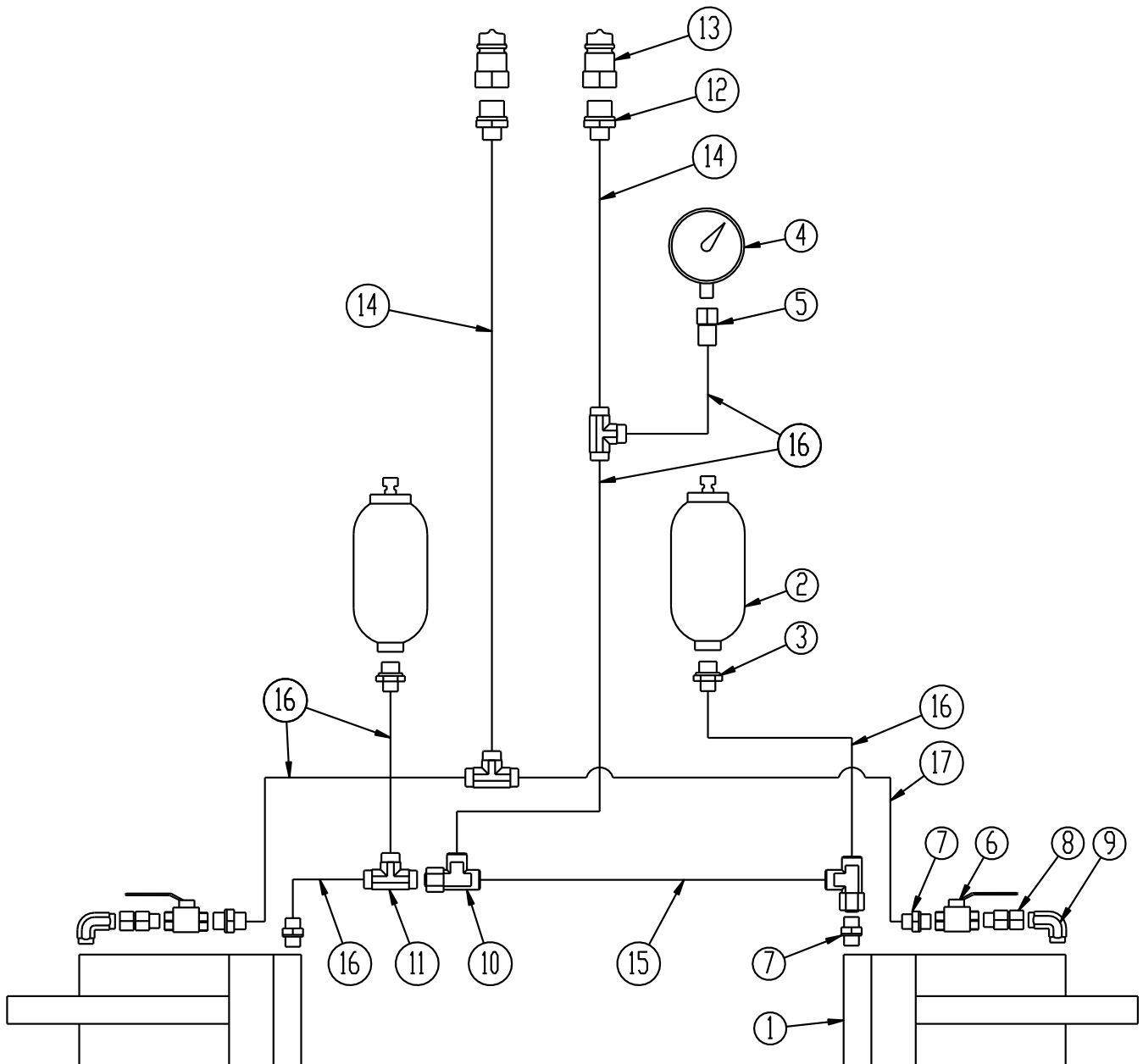

Pos.	Part no.	Description	Qty.
1	7345125	Cylinder 90/40 x 400 ϕ 35/35	2
2	690206410	Accumulator H700R 40 bar	2
3	690203097	Fitting straight M18x1,5x10	2
4	0442052	Manometer	1
5	690206825	Manometer fitting ϕ 12x1/4"	1
6	0442350	Ball valve 3/8"	2
7	0446751	Fitting straight ϕ 10 x 3/8"	4
8	690203130	Fitting adjustable 12-3/8" mounted with O-ring	2
9	690203106	Fitting 90° 12-3/8" BSP	2
10	690203120	Connector adjustable T10 mounted with O-ring	2
11	690203015	Connector T10	3
12	0446752	Fitting straight ϕ 10 x 1/2"	2
13	0444020	Quick coupling 1/2", male	2
14	0454577	Hydraulic hose 1/4" L = 1950 mm	2
15	0454166	Hydraulic hose 1/4" L = 450 mm	1
16	0454140	Hydraulic hose 1/4" L = 350 mm	6
17	0454250	Hydraulic hose 1/4" L = 1010 mm	1



as it looks

As good as it looks

As good as it looks

As good as it looks

As good as it looks

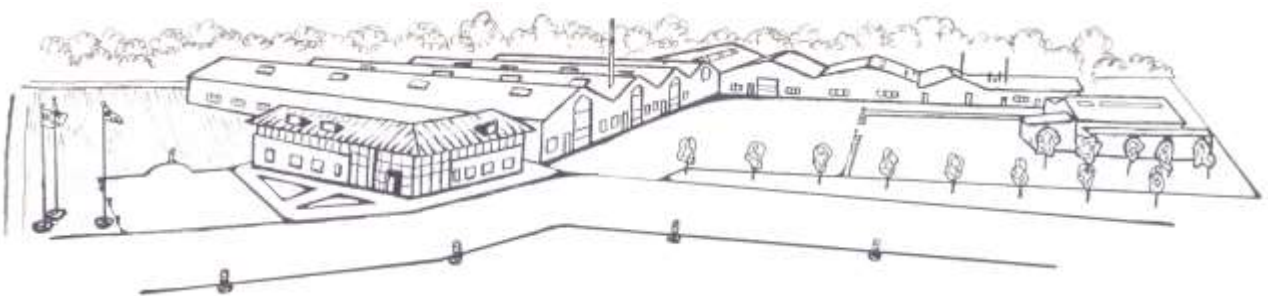

The design is subject to modification without notice.