

UK

HE-VA

Operating Instructions
Spare Parts List
Declaration of Conformity

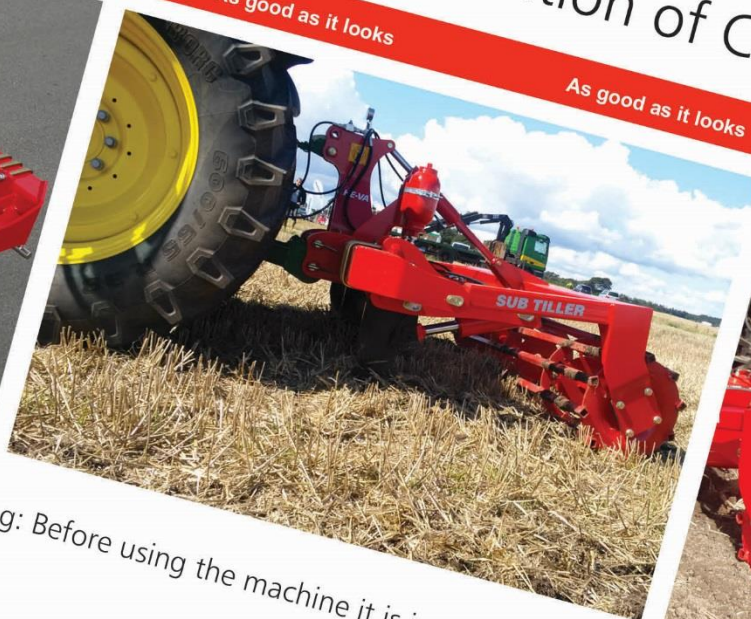

Warning: Before using the machine it is important to read the operation instructions.

Sub-Tiller Eco 2,5 – 3,0 – 3,5 m



N. A. Christensensvej 34
DK-7900 Nykøbing Mors
Tel: 97724288
Fax: 97722112
www.he-va.com

Contents

EC DECLARATION OF CONFORMITY	4
Delivery check	5
Machine description.....	5
Range of application	5
Technical specifications.....	5
Safety instructions for Sub-Tiller ECO	6
Safety and instructions on Hydraulics	7
Transport on public roads	7
Front axle load	7
Labels on the machine	8
Start-up of the machine.....	9
General information.....	9
Attachment and uncoupling	9
Settings and adjustment	9
Stone protection	9
Hydraulic auto-release system	10
Scrapers.....	11
Replacement of wearing point	12
Maintenance	13
Lubrication.....	13
Points of lubrication.....	14
Spare part list.....	16
Frame 2,5 - 3,0 - 3,5 m.....	16
Roller and scraper	18
Tine w/hydraulic auto-release system.....	20
Tine w/Quick-Push shear bolt.....	22
Jack stand.....	24
LED-Light.....	25
Spare part list - Hydraulics.....	26
Support for accumulator	26
Hydraulics for roller depth control	27
Hydraulics for auto-release system (rigid).....	28
Notes.....	30



EC DECLARATION OF CONFORMITY

in accordance with the EU Machinery Directive 2006/42/EC
applicable as from December 29th 2009:

HE-VA ApS
N. A. Christensensvej 34,
DK-7900 Nykøbing Mors

hereby confirms that the following machine has been manufactured in accordance with the Council
Directive 2006/42/EC.

The declaration comprises the following machine:

Sub-Tiller ECO 2,5m – 3,0m – 3,5m

Nykøbing 01.04.2015

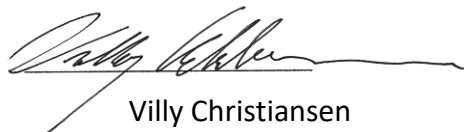
A handwritten signature in black ink, appearing to read "Villy Christiansen".

Villy Christiansen

The undersigned is furthermore authorized to compile technical documentation for the above machine.

Delivery check

Upon delivery to the dealer/supplier as well as to the customer, check the Sub-Tiller ECO for possible damages.

Machine description

Range of application

Sub-Tiller ECO is a sub-soiler for soil loosening from 0 cm to 60 cm depth.

The work is performed either before seeding (min. tillage) or after harvest where a loosening of the tramlines in the field is desirable in order to counter structure damages. Infinitely variable tine spacing, allows for adapting to the the specific task. Sub-Tiller ECO is ideal for all soil types; a V-profile roller is recommended for moist and sticky soil types, while a square tube roller is suitable for lighter soil types. Sub-Tiller ECO can be mounted with HE-VA Multi-Seeder which opens up the possibility of till-seeding of rape or crops for green manure.

Sub-Tiller is mounted in the tractor's three-point suspension, and the hydraulic depth control via the packer roller is controlled by the hydraulic system of the tractor. In order to achieve optimum control be aware of the tractor wheel type, under certain circumstances a mounting of twin wheels is recommended.

Technical specifications

Working width	Type of stone protection	No. of tines	Transport width in m	Power requirement HP	Max. HP	Weight kg			
						Without roller	Square tube roller	V-profile roller	
2,50 m rigid	Shear bolt	2	2,50	60-100	250	490	850	1.365	
		3	2,50	90-120	250	570	930	1.445	
	Quick-Push shear bolt	2	2,50	60-100	250	500	860	1.375	
		3	2,50	90-120	250	580	940	1.445	
	Hydr. auto-release system	2	2,50	60-100	250	540	900	1.405	
		3	2,50	90-120	250	630	990	1.495	
3,00 m rigid	Shear bolt	2	3,00	60-100	250	510	920	1.540	
		3	3,00	90-120	250	590	1.000	1.620	
		4	3,00	60-110	250	660	1.070	1.690	
		5	3,00	130-200	250	750	1.160	1.780	
	Quick-Push shear bolt	2	3,00	60-100	250	520	930	1.550	
		3	3,00	90-120	250	600	1.010	1.630	
		4	3,00	110-60	250	680	1.090	1.710	
		5	3,00	130-200	250	770	1.180	1.800	
	Hydr. auto-release system	2	3,00	60-100	250	580	990	1.610	
		3	3,00	90-120	250	690	1.100	1.720	
		4	3,00	110-260	250	810	1.220	1.840	
		5	3,00	130-200	250	930	1.340	1.960	
	3,50 m rigid	Shear bolt	5	3,50	130-200	250	760	1.240	1.960
		Quick-Push shear bolt	5	3,50	130-200	250	780	1.260	1.980
		Hydr. auto-release system	5	3,50	130-200	250	900	1.380	2.100

Sub-Tiller ECO complies with DS/ISO 11001-1, three-point suspension.

Safety instructions for Sub-Tiller ECO

Do not start-up the machine if there are persons in exposed positions* within a hazardous area**.

When persons are in exposed positions (e.g. in connection with adjustment, maintenance, attachment and uncoupling), the following conditions must be observed:

1. The machine must be lowered to firm ground.
2. The hydraulics must be relieved.
3. The tractor must be stopped and the key removed from the ignition switch.
4. The driver must ensure that no persons are staying in exposed positions during the operation.

* Person in exposed position: Any person who is staying wholly or partly within a hazardous area.

** Hazardous area: On and under the machine within a distance of 4 m from the machine.

Most accidents that happen in connection with the operation, transport and maintenance of machines are caused by non-compliance with the most elementary safety conditions.

Therefore, it is vital that anybody working at the machine carefully complies with the safety instructions as well as other instructions applying to the machine.

The machine should only be operated, maintained and repaired by persons, who are familiar with this work and who are further familiar with the possible elements of danger with this particular machine.

ATTENTION !! Rotary parts and loose clothes are a dangerous combination.

IMPORTANT !! In connection with the risk of parts falling down, it may endanger the lives of persons staying on the base frame of the machine, when it is operated attached to a tractor.

Safety and instructions on Hydraulics

1. The maximum working pressure is 225 bar.
2. It is advisable to label the attachment parts at hydraulic connections between the tractor and the tool in order to eliminate incorrect operation!
3. When checking for hydraulic leaks, use suitable safety wear (eye protectors, gloves, etc.)
High-pressure hydraulic oil may penetrate the skin and cause dangerous injuries.
In case of injury, consult a doctor immediately. **RISK OF INFECTION!**
4. Before operating the hydraulics, lower the machine to firm ground.
Relieve the hydraulics, stop the motor and remove the ignition key.
5. Check the hydraulic hoses on a regular basis, however, every six months as a minimum due to any cracks, wear and tear, etc. Replace any defective hoses immediately.

The life of hydraulic hoses is maximum 5 years.

New hydraulic hoses must meet the manufacturer's requirements.

Transport on public roads

Check before transport on public roads that the attachment of the machine at the tractor is in accordance with the local rules and regulations in force (permitted total weight, permitted axle load, transport width, lights, warning signs, etc.).

Front axle load

After the attachment of the machine and at maximum load, the driving properties of the tractor must be ensured. Check that the front axle is sufficiently loaded. As a minimum, the front axle load must be 20% of the tractor weight. Permitted axle load and permitted total weight for the tractor must always be observed.

NB! The driving, controlling and braking properties are affected by the attached machine combination.

Labels on the machine

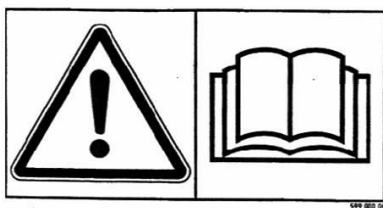

Study the Operating Instructions thoroughly before any operation of the machine and observe all safety instructions.



Plate with number and year of manufacture.

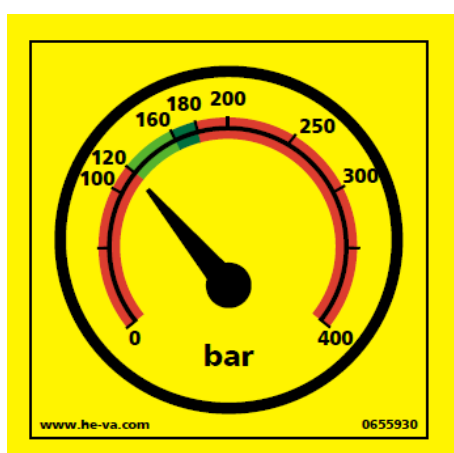

Correct hydraulic pressure on the release system.

Hydraulic systems.

Yellow: Hydraulic stone release system

**HUSK - PLEASE NOTE -
ACHTUNG - ATTENTION**
EFTERSPÆND BOLTE
TIGHTEN UP THE BOLTS
BOLZEN NACHZIEHEN
RESSERRER LES BOULONS

Tighten up all bolts regularly. If this is not performed, our guarantee obligations will no longer apply.

Maximum torque in Nm. w/lubricated thread			
Metric thread	Quality 8.8	Quality 10.9	Quality 12.9
M10x1,5	47	65	79
M12x1,75	81	114	136
M14x2,0	128	181	217
M16x2,0	197	277	333
M18x2,5	275	386	463
M20x2,5	385	541	649
M22x2,5	518	728	874
M24x3,0	665	935	1120
Wheel nut M18x1,5 fine thread		433 Nm	
Wheel nut M22x1,5 fine thread		803Nm	

Start-up of the machine

General information

The machine requires 1 double acting outlet.

Attachment and uncoupling

1. Under normal circumstances, attach the tractor in the lowest lifting points of the machine both as regards the lifting arms and the top link.
2. When the machine is to be parked and uncoupled from the tractor, it is important, that the roller is placed in the lowest position, so that the machine is placed stably.
3. When uncoupling, relieve the tractor's oil outlet, and the machine's quick couplings can be uncoupled without pressure.

Settings and adjustment

Stone protection

Quick-Push shear bolt

When the shear bolt is broken and the tine has been released, place the shear bolt one notch forward before the machine can operate again.

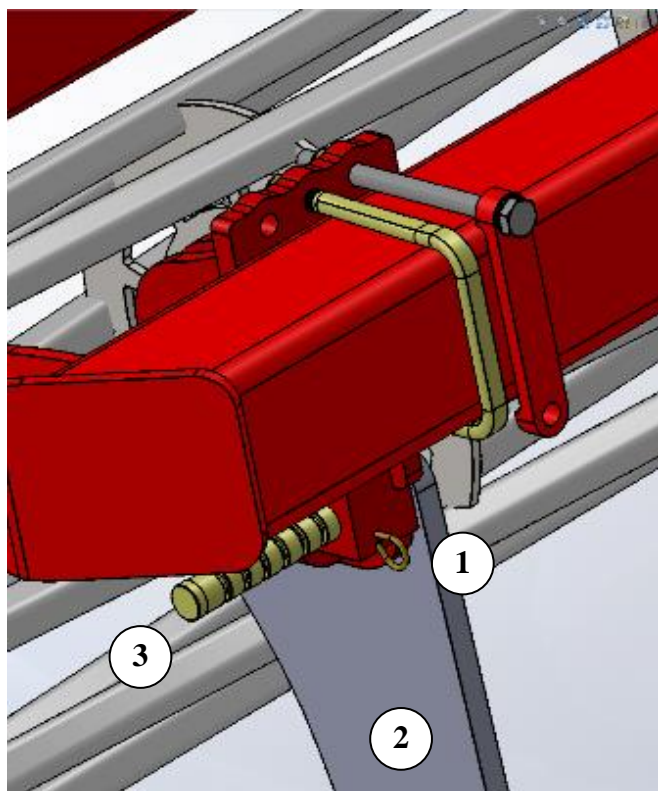

Pull out the R-clip (Pos. 1).

Pull the tine back to normal working position (Pos. 2).

Push the shear bolt (Pos. 3) **one** notch forward to a new position in the tine. Do not push the bolt totally through (it may be necessary to remove soil etc. from the hole in the tine).

⚠ Important: It is not recommended to be under the machine while the shear bolt is being moved or replaced.

Push back the R-clip (Pos. 1), so that it locks the shear bolt in place, and the machine is ready for operation.

When the shear bolt is broken for the 8th time, it is used up. Note that the shear bolt must **never** be shorter than 65 mm.

When a new shear bolt is mounted it is important that it is placed correctly. The 40 mm end (Pos. 3) must turn away from the tine.

Hydraulic auto-release system

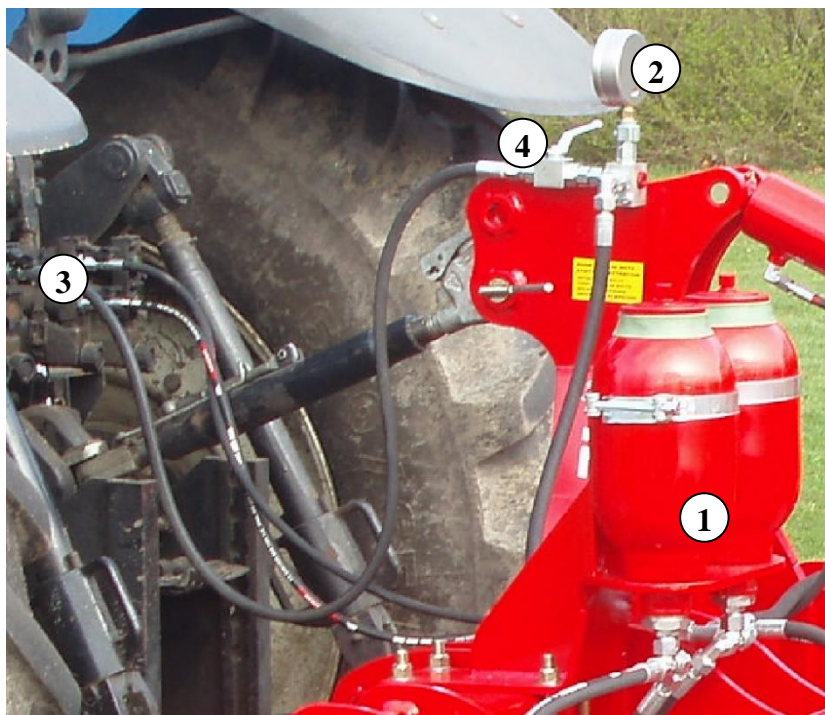

1. Before each season, check that the gas pressure of the accumulators (Pos.1) is at 110 bar.
⚠ This requires special tools and should only be performed by an authorized dealer.
2. Before start-up of the machine, check the hydraulic pressure in the closed hydraulic stone protection system on the machine's pressure gauge (Pos. 2). The pressure should be **minimum 120 bar** and must not exceed 160 bar.
3. **IMPORTANT** – check the hydraulic pressure continuously, to ensure that it stays above 120 bar.
4. If there is a need to adjust the working pressure, follow these instructions:
 - a. Mount the quick coupling of the hydraulic hose (Pos. 3) in the tractor oil outlet.
 - b. Turn on the ball valve (Pos. 4), and the working pressure can now be adjusted up or down with the tractor's oil outlet.
 - c. When the desired pressure is achieved, turn the ball valve off again (Pos. 4), and the tractor's hydraulic system is relieved before the quick coupling (Pos. 3) is dismantled and placed in the parking device of the machine.

5. During operation of the machine, the tine swings automatically to the rear if it meets an obstacle. In normal circumstances, the tine will automatically return to working position again after having passed the obstacle. At extreme obstacles and/or soil conditions, it might be necessary to stop and eventually lift the machine from the soil.

It is important that no persons are near to the machine, as the tine returns to working position at high speed and might throw soil and stones.

Scrapers

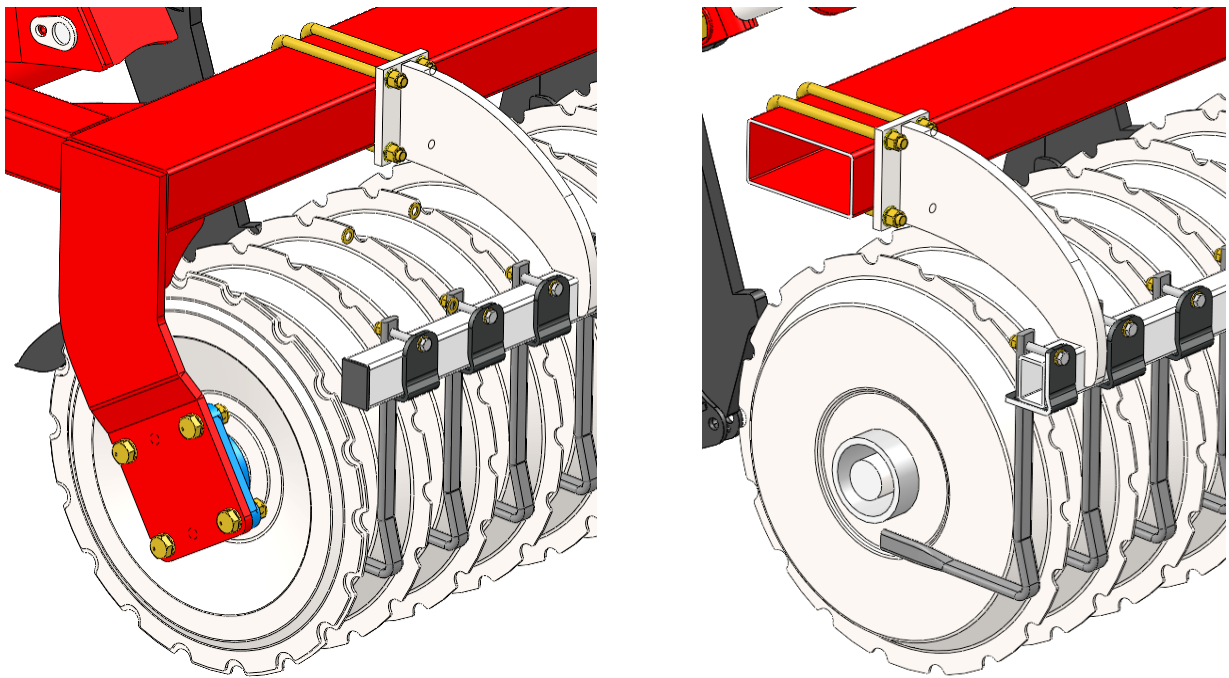

Sub-Tiller ECO with V-profile roller is equipped with special steel scrapers.

Check the centering daily in order to avoid unnecessary wear and to ensure optimal effect.

Replacement of wearing point

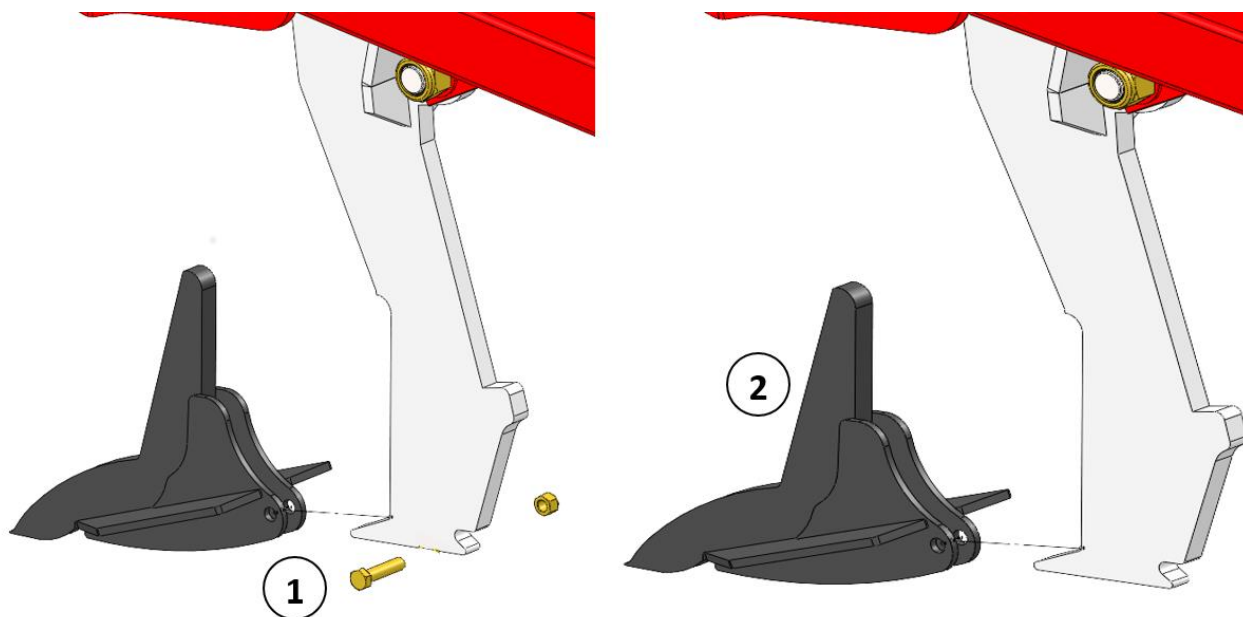

Before working with the wearing points, the machine must be secured. This can be performed by placing trestles under the main frame or by supporting the roller.

The wearing point might fall off when the shear bolt is removed - risk of foot or leg injury!

1. Dismount bolt (Pos. 1) by means of 2 pcs. spanners.
2.  The wearing point might fall off, when the shear bolt is removed – risk of foot or leg injury.
3. Dismount the wearing point by pushing it forward. This might be difficult due to entrance of soil, and it might be a good idea to use a hammer.
4. Check the bolt for any damages and replace if required. **Reorder the original bolt by replacing. It is a special bolt that secure that the wings isn't tightened**
5. Mount the bolt (Pos. 1), lubricate and tighten it to 20 Nm.
Be careful not to tighten the bolt too much, as it might damage the wearing point!

Maintenance

- After 10 hours of operation, **retighten** the machine. Check hydraulic hoses, fittings and cylinders for leaks and retighten. See table below.
- Further, check regularly that all bolts are **tightened**.
- Before winter storage, wash and lubricate the machine. If you are using a high-pressure cleaner, do not spray directly on the ball bearings. After the washing, you may spray the machine with oil.

Maximum torque in Nm. w/lubricated thread			
Metric thread	Quality 8.8	Quality 10.9	Quality 12.9
M10x1,5	47	65	79
M12x1,75	81	114	136
M14x2,0	128	181	217
M16x2,0	197	277	333
M18x2,5	275	386	463
M20x2,5	385	541	649
M22x2,5	518	728	874
M24x3,0	665	935	1120
Wheel nut M18x1,5 fine thread	433 Nm		
Wheel nut M22x1,5 fine thread	803Nm		

Lubrication

Typical lubricating points are by the stone release points, by the roller bearings, the cylinders, and where the roller hinges on the bar. The points must be lubricated after every 10 working hours as well as after the cleaning in order to press out any water and dirt.

During lubrication, maintenance and repair, the Sub-Tiller ECO must be lowered, the tractor braked and the engine off.

Attention! The double-sealed ball bearings in the roller should only be lubricated every 20 working hours and by 1-2 strokes, so that the sealing rings are not pressed out.

Important: The hydraulic system has been filled with oil type Hydro Texaco HD32

Points of lubrication

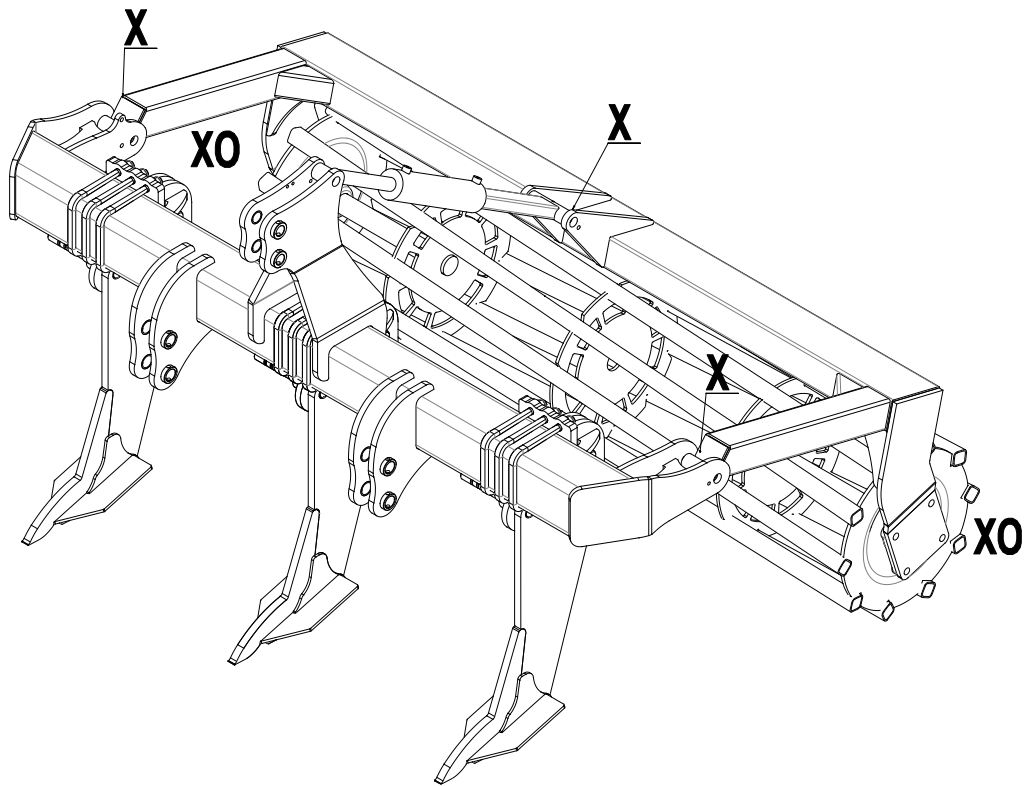
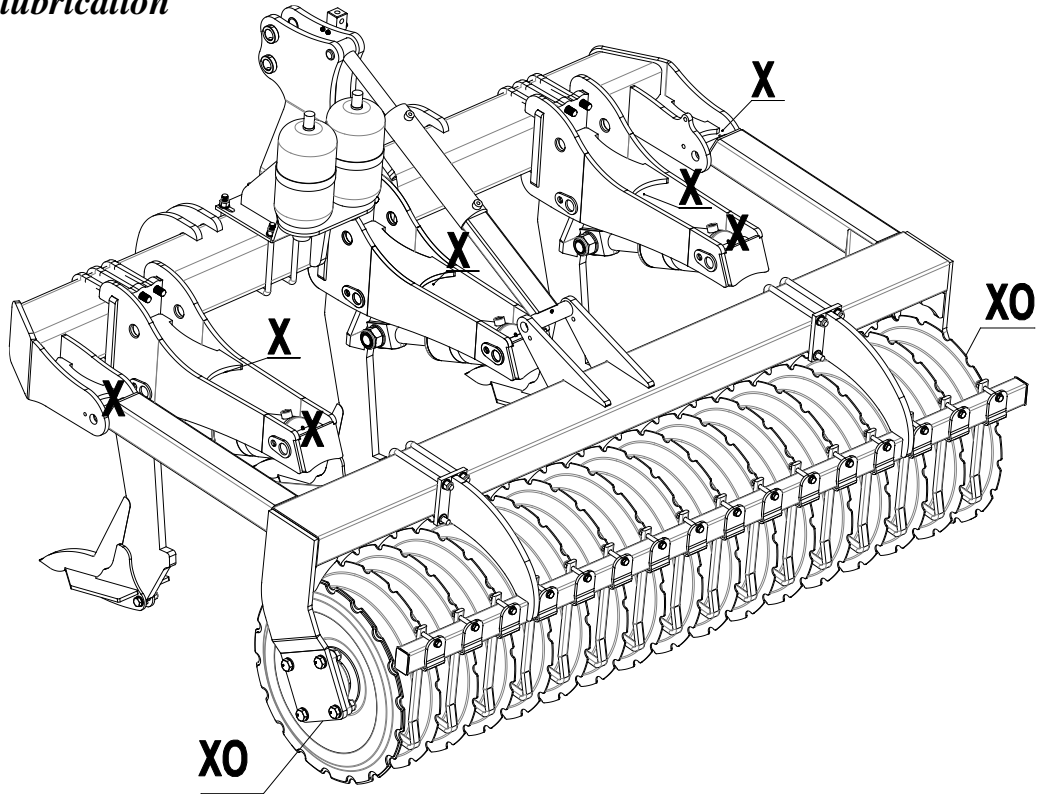

Attention! X - O The double-sealed ball bearings in the roller should only be lubricated every 20 working hours and by 1-2 strokes, so that the sealing rings are not pressed out.
Important: The hydraulic system has been filled with oil type Hydro Texaco HD32

Spare part list

Frame 2,5 - 3,0 - 3,5 m

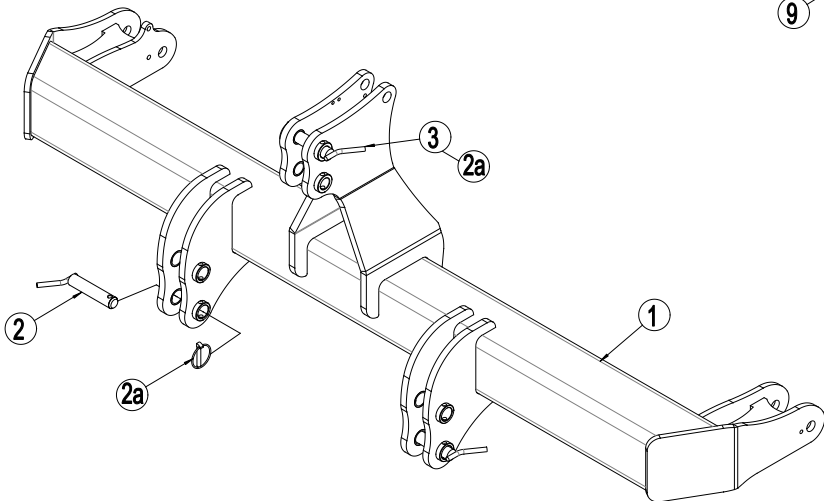
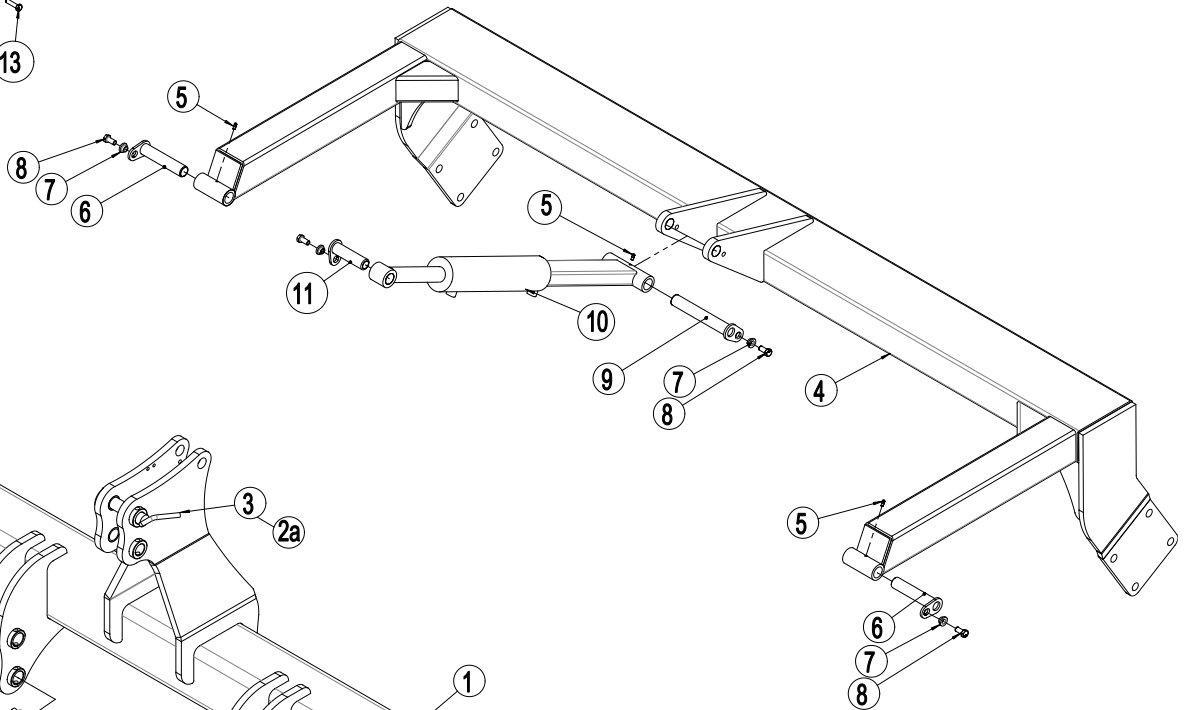
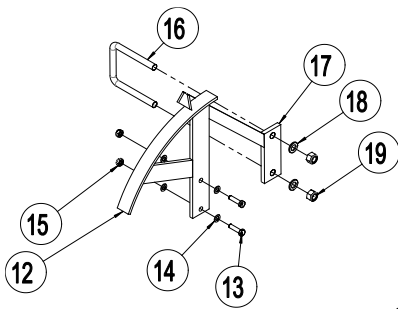
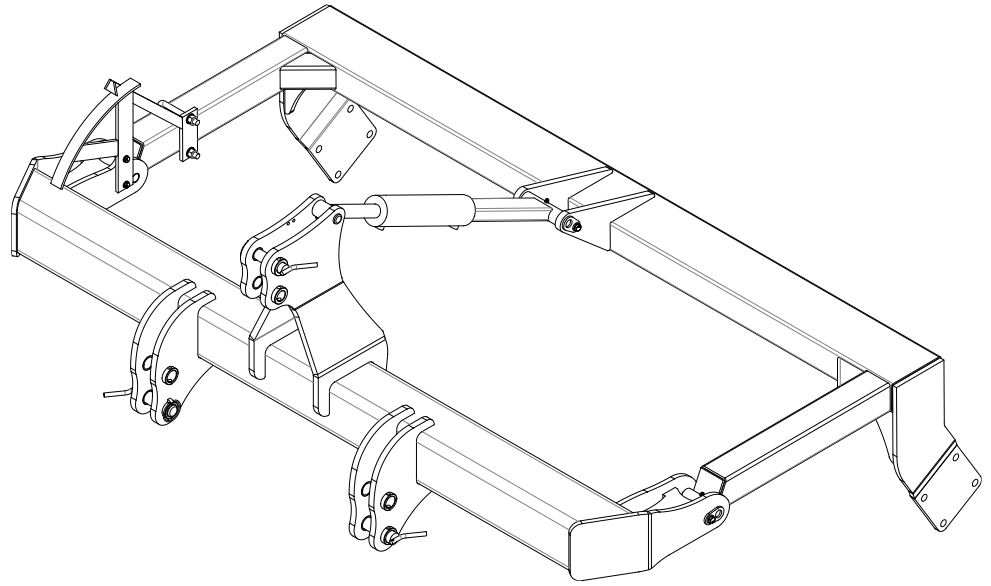

Pos.	Item no.	Designation	2,5 m	3,0 m	3,5 m
1	645410038	Frame 2,5 m From serial no. 31432	1		
1	645410029	Frame 3,0 m From serial no. 31432		1	
1	645410040	Frame 3,5 m From serial no. 31432			1
2	69537129B	Pin Ø37 L=129 (for top link Cat. III) w/handle and cotter slot	2	2	2
2a	690134008	Ring pin Ø11,5	3	3	3
3	69532129B	Pin Ø32 L=129 (for top link Cat. III) w/handle and cotter slot	1	1	1
4	645000153	Roller bar 2,5 m	1		
4	645000027	Roller bar 3,0 m		1	
4	645000156	Roller bar 3,5 m			1
5	0432510	Lubricating nipple M8	2	2	2
6	69430145G	Pin Ø30 L=145	2	2	2
7	630532600	Lock bush for pin head	4	4	4
8	0235330	Bolt M12x25 8.8	4	4	4
9	69430200G	Pin Ø30 L=200	1	1	1
10	645410007	Cylinder for depth adjustment 80/40x280	1	1	1
10a	690200143	Gasket set 80/40 (Laizhou)			
11	69430107G	Pin Ø30 L=107	1	1	1
12	645000162	Scale for depth control	1	1	1
13	0235070	Bolt M10x40 8.8 (set screw)	2	2	2
14	0272260	Facet plate Ø10	4	4	4
15	0264060	Self-locking nut M10	2	2	2
16	0382160	U-bolt M16 100x100x100	1	1	1
17	645000165	Indicator f/depth control	1	1	1
18	0272290	Facet plate Ø16	2	2	2
19	0264090	Self-locking nut M16	2	2	2

Roller and scraper

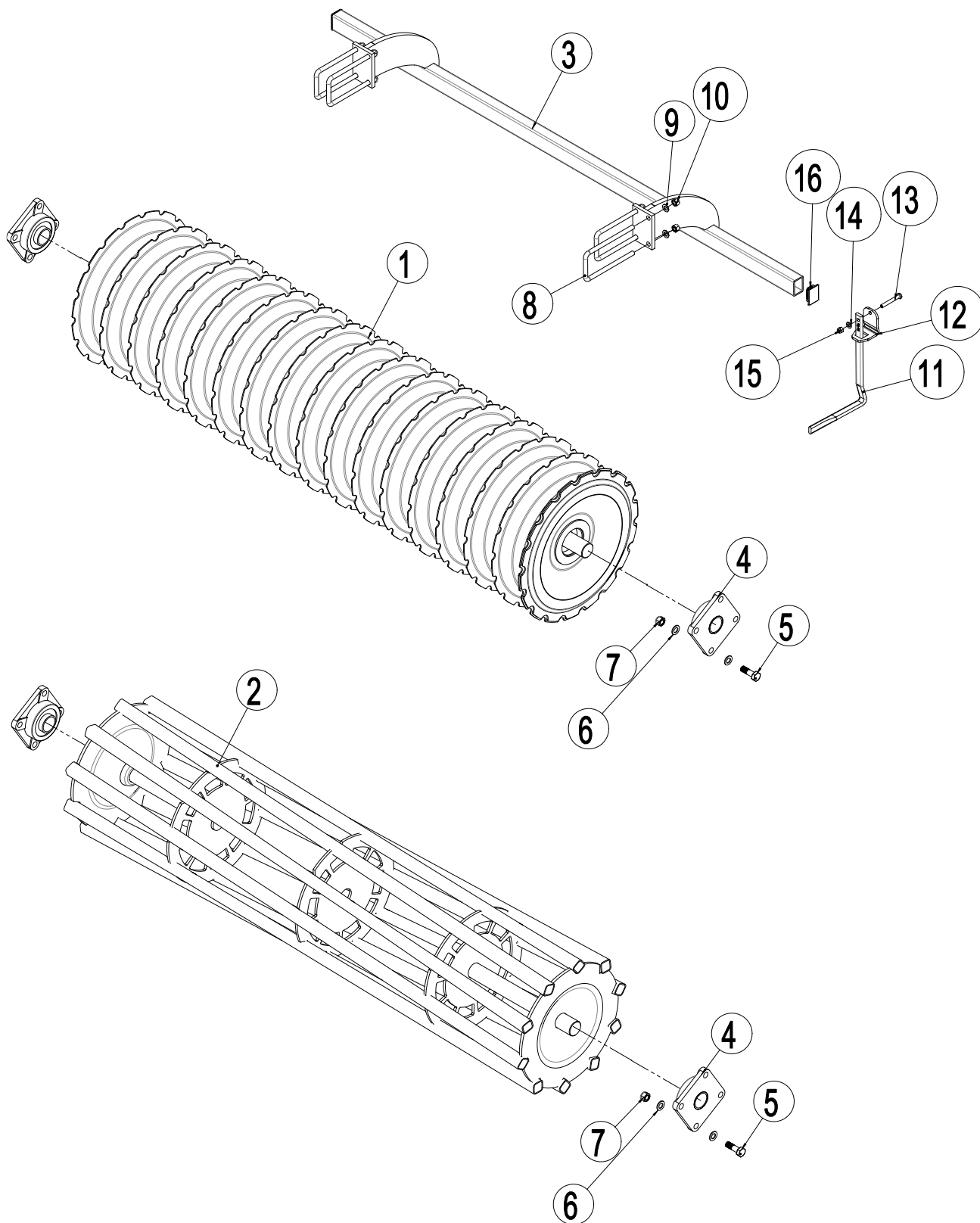

Pos.	Item no.	Designation	2,5m	3,0m	3,5m
1	1160468	V-profile roller, 2435 mm	1		
1	1160470	V-profile roller, 2935 mm		1	
1	1160480	V-profile roller, 3435 mm			1
2	1048210	Square tube roller Ø550 2,5 m	1		
2	1048240	Square tube roller Ø550 3,0 m		1	
2	1048280	Square tube roller Ø550 3,5 m			1
3	645000707	Scraper bar 2,5 m	1		
3	645000799	Scraper bar 3,0 m		1	
3	645000827	Scraper bar 3,5 m			1
4	0478971	Bearing UCF 312 Ø60	2	2	2
5	0236140	Bolt M20x65 8.8	8	8	8
6	0272310	Facet plate Ø20	16	16	16
7	0264110	Self-locking nut M20	8	8	8
8	690110106	U-bolt M16x200x100x200	4	4	4
9	0272290	Facet plate Ø16	8	8	8
10	0264090	Self-locking nut M16	8	8	8
11	630938520	Scraper, short – twisted 255mm	16	19	22
12	630838522	Clamp 50x70 f/scraper	16	19	22
13	0235450	Bolt M12x90 8.8	16	19	22
14	0272270	Facet plate Ø12	32	38	44
15	0264070	Self-locking nut M12	16	19	22
16	0489487	Plastic stopper f/sectional tube 70x20x2, black	2	2	2

Tine w/hydraulic auto-release system

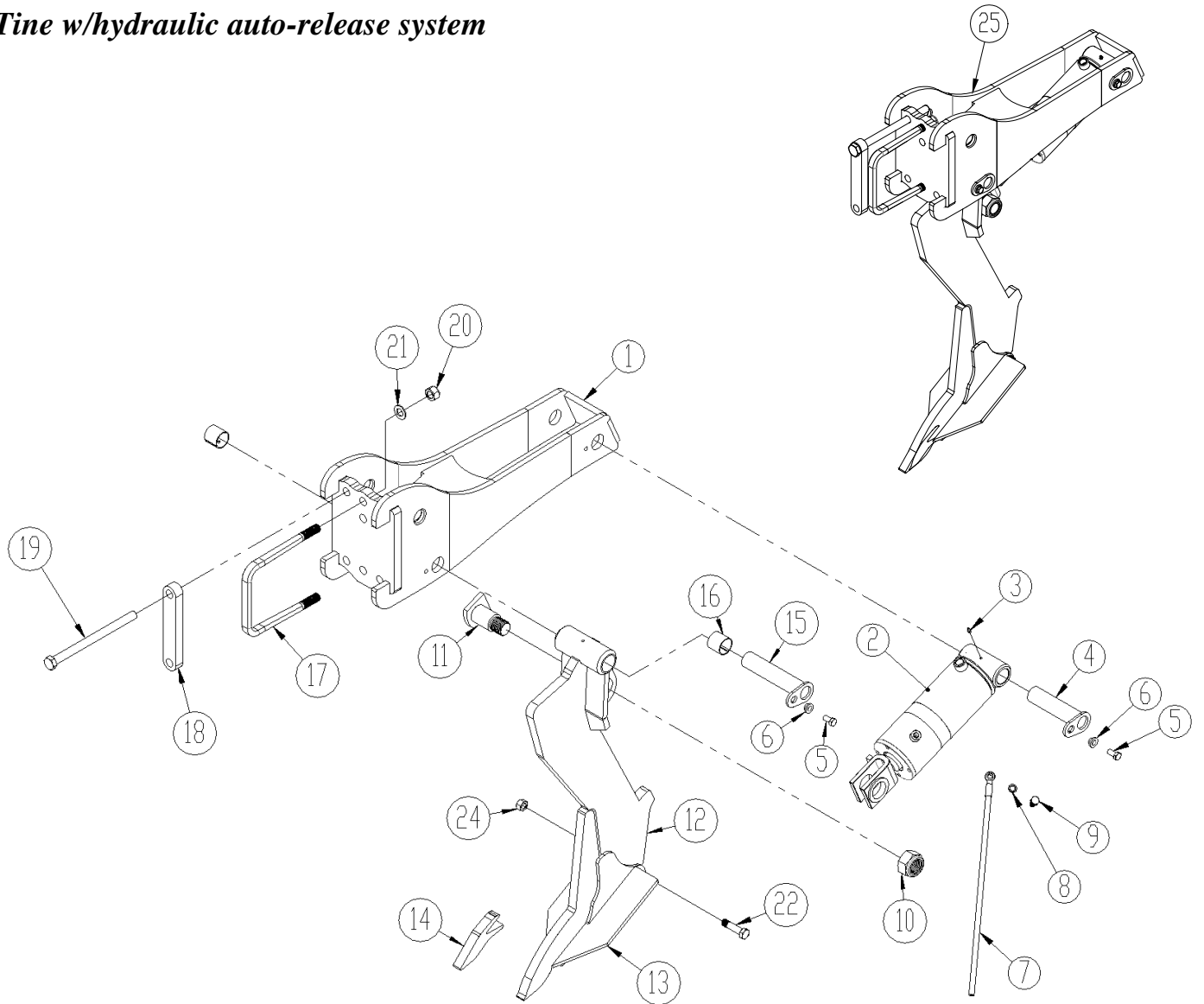

Pos.	Item no.	Designation	No. per tine
1	645410001	Cpl. tine bracket	1
2	0467402	Cylinder Ø110/50x165 w/yoke (until 31/12 2018)	1
	0467405	Cylinder 110/50x165 w/yoke (from 1/1 2019)	1
2a	690200313	Gaset set for 0467402	
	0467470	Gaset set for 0467405	
3	0432523	Lubricating nipple M8x1,25 90°	1
4	69440165G	Pin Ø40 L=165	1
5	690101101	Bolt M12x25 8.8	2
6	630532600	Lock bush for pin head	2
7	0451700	Hydraulic hose ¼" x 1500 mm – w/banjo joint	1
8	0449050	Bonded seal ¼" PP45B	2
9	0444950	Banjo bolt ¼"	1
10	0264190	Self-locking nut M36	1
11	645000500	Cpl. wear pin f/hydraulic tine	1
12	645000086	Tine for hydraulic automatic release system	1
	645001100	Tine for hydraulic automatic release system w/ 1 hardmetalplate	1
	1240001	Tine for hydraulic automatic release system w/ 2 hardmetalplate	1
	645000557	Tine for hydraulic automatic release system (+100mm)	1
13	645000043	Points w/120 mm wing shares	1
	645000044	Points w/200 mm wing shares	1
	645000044T	Points w/200 mm wing shares w/hardmetal	1
	645000063	Points w/350 mm wing shares	1
14	645000045	Wearing point for surface welding	
15	69440195G	Pin Ø40 L=195	1
16	0475100	Slide bush Ø40/Ø44 L=40	2
17	690110500	U-bolt M20x180x180x180 mm (Ø20/14x24,5 mm)	1
18	645410052	Flange (from machine nr. 34680)	2
19	0236315	Bolt M20x280	4
20	0264110	Self-locking nut M20	6
21	0272310	Facet plate Ø20	10
22	0235852	Bolt M16x65 8.8 (special bolt)	1
24	0264090	Self-locking nut M16	1
25	645000114	Complete tine	

Tine w/Quick-Push shear bolt

Right model shown below. For left model, reverse image.

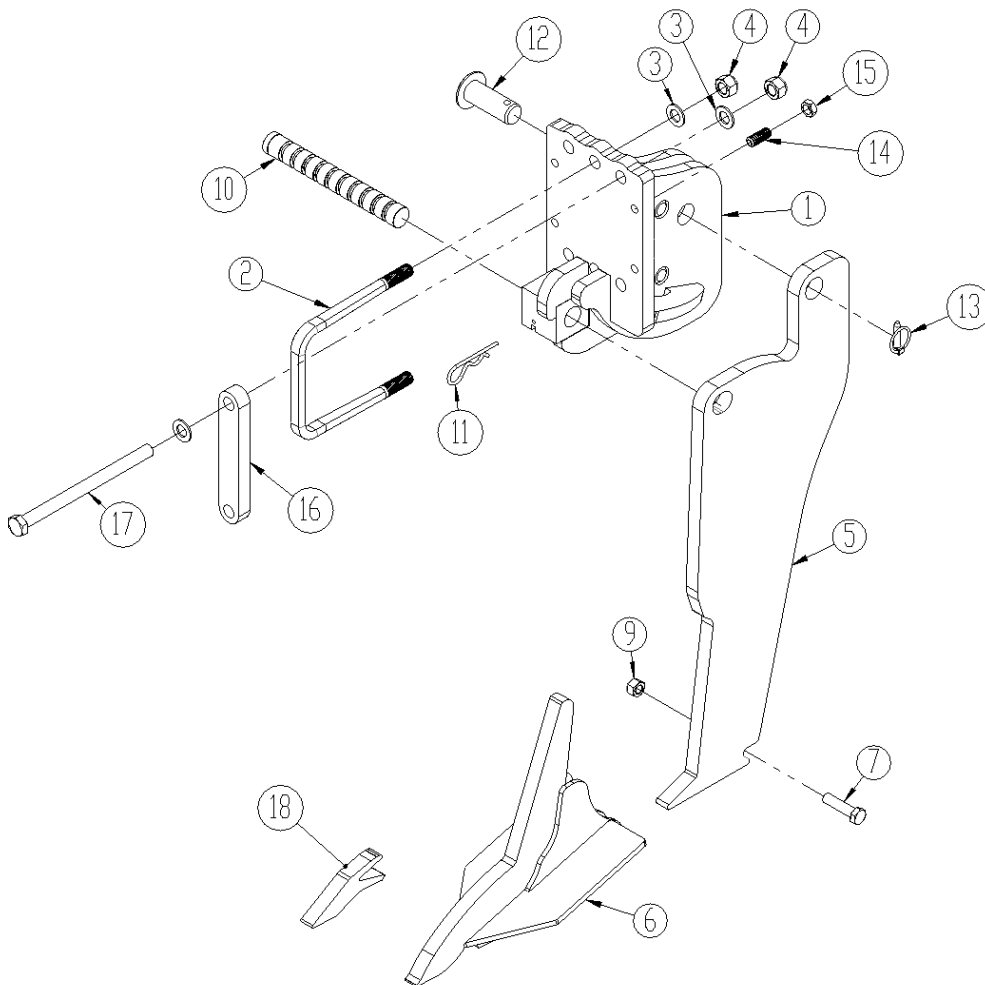
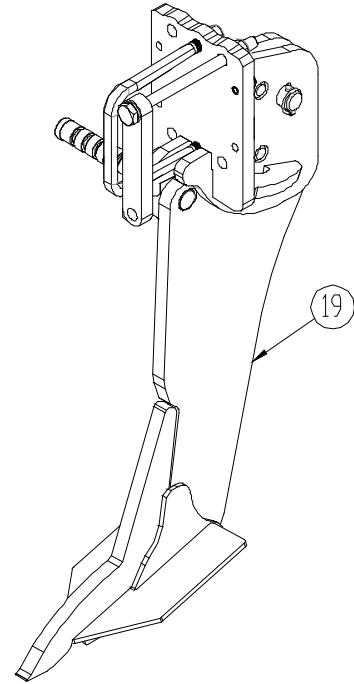

Pos.	Item no.	Designation	No. per tine
1	1245038	Tine bracket f/Quick-Push, right	1
1A	1245016	Tine bracket f/Quick-Push, left	1
2	690110500	U-bolt M20x180x180x180 mm (Ø20/14x24,5 mm)	1
3	0272310	Facet plate Ø20	10
4	0264110	Nut M20	6
5	645000062	Tine f/Quick-Push	1
	645000061	Tine for Quick-Push (+100mm)	1
	1240425	Tine for Quick-Push w/ 1 hardmetalplate	1
	1241163	Tine for Quick-Push w/ 2 hardmetalplate	1
6	645000043	Points w/120 mm wing shares	1
	645000044	Points w/200 mm wing shares	1
	645000044T	Points w/200 mm wing shares w/hardmetalplate	1
	645000063	Points w/350 mm wing shares	1
7	0235852	Bolt M16x65 (special bolt)	1
9	0264090	Self-locking nut M16	1
10	645000059	Springbolt Ø35 (chromated)	1
11	0377600	R-clip Ø6	1
12	69435070F	Pin Ø35 L=71	1
13	0378600	Ring pin Ø10	1
14	0227528	Pivot screw M16x40	4
15	0261392	Counter nut M16	4
16	645410052	Flange (from machine nr. 34680)	2
17	0236315	Bolt M20x280	4
18	645000045	Wearing point for surface welding	
19	1245020	Complete tine (pos 1-17) left	
19A	1245036	Complete tine (pos 1-17) right	

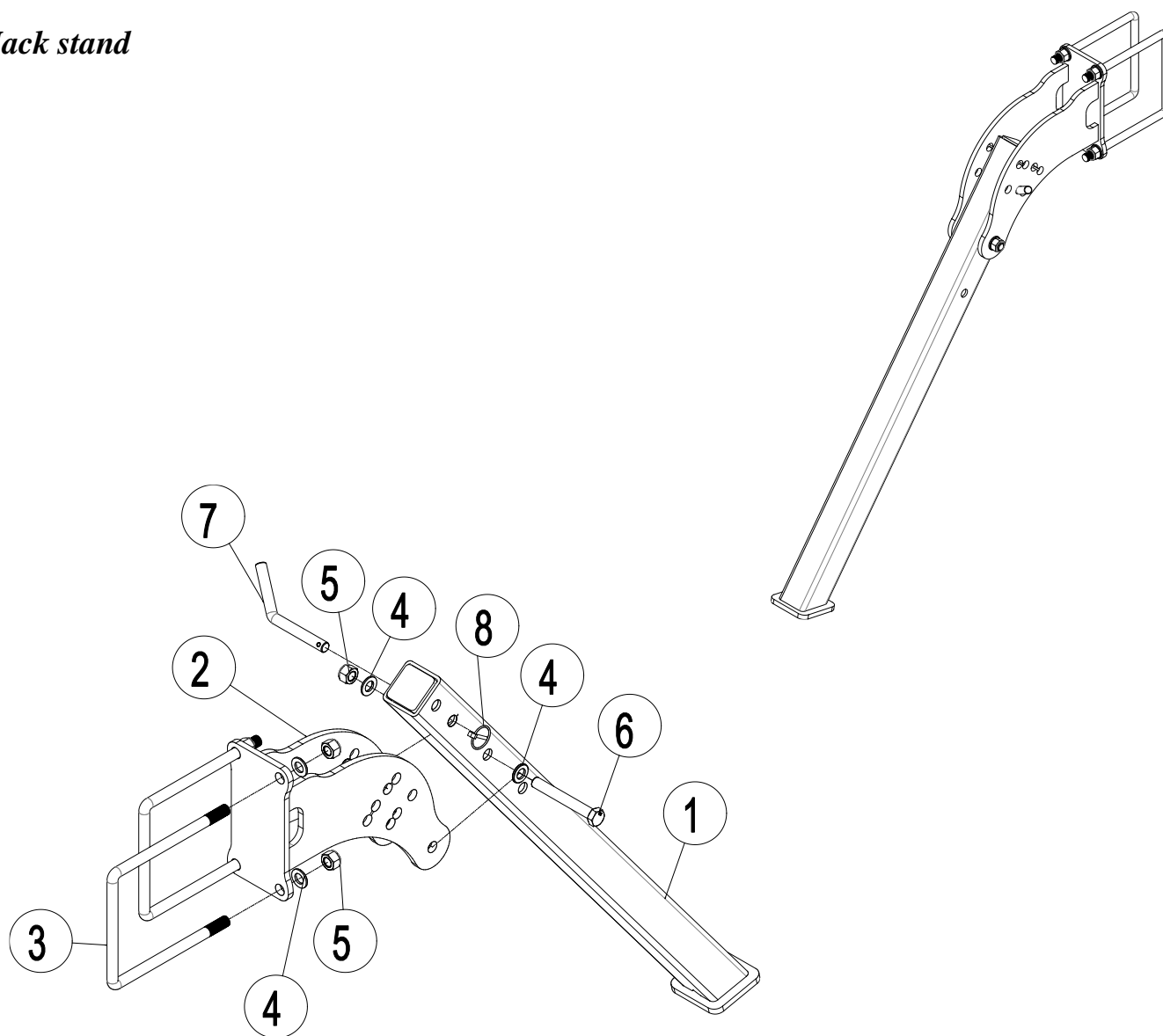
Jack stand

Pos.	Item no	Designation	No.
1	645100153	Jack stand	1
2	645100149	Bracket for jack stand	1
3	690110109	U-bolt M16x180x180x180	2
4	0272290	Facet plate Ø16	6
5	0264090	Self-locking nut M16	5
6	0235920	Bolt M16x120 8.8	1
7	69516094A	Pin for jack stand Ø16 L=94 45°	1
8	0378200	Ring pin Ø4,5mm	1

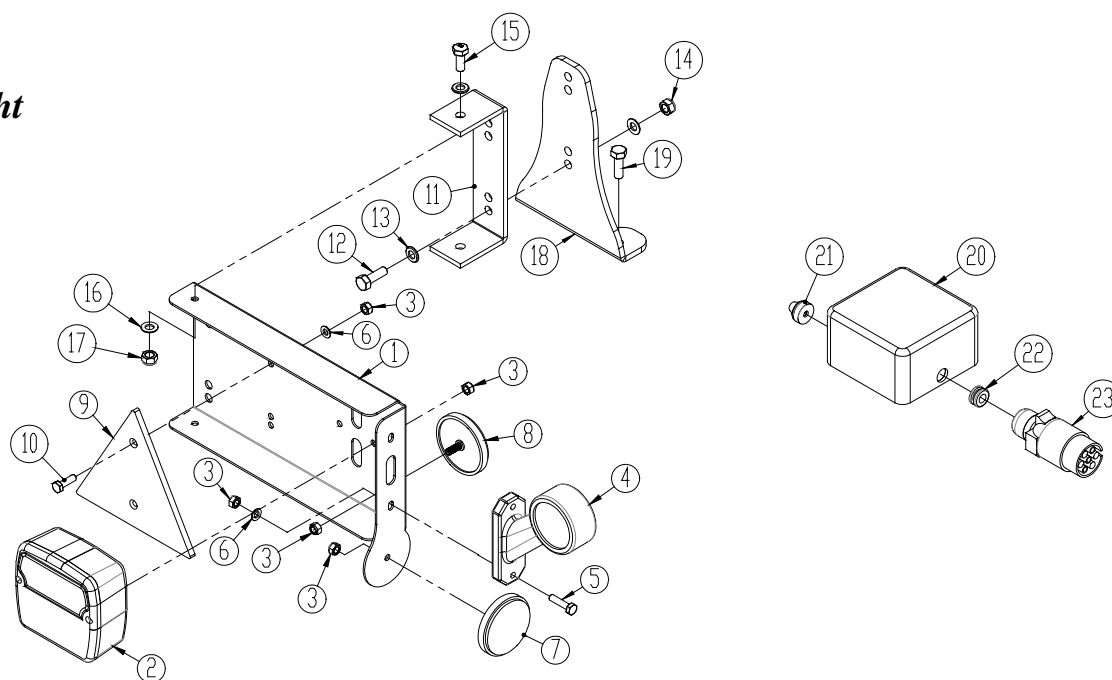
LED-Light

Pos.	Item no.	Designation	Number
1	7357505	Light bracket, left	1
	7357508	Light bracket, right	1
2	7357504	Rear light	2
3	0264030	Self-locking nut M5	
4	7357507	Marking lights (V)	1
	7357509	Marking lights (H)	1
5	0233860	Bolt M5x20	
6	0272230	Facet plate Ø5	
7	0656240	Reflex, yellow	2
8	0656250	Reflex, white	2
9	0521030	Reflex, red	2
10	0233860	Bolt M5x20	
11	7357516	Bracket	2
12	0234760	Bolt M8x25	
13	0272250	Facet plate Ø8	
14	0264050	Self-locking nut M8	
15	0234330	Bolt M6x20	
16	0272240	Facet plate Ø6	
17	0264040	Self-locking nut M6	
18	30910110	Consol	2
19	0230825	Taptite bolt M8x25	
20	0520492	Connecting box 105x105x60	1
21	7357545	Rutaseal nippel M20 8-12mm	2
22	7357546	Rubber bushing	1
23	0527140	Plug 7 poles DIN 72 577 – ISO 1724	1
	690160080	Cable 5x1mm ²	

Attention: The number of hoses and hose lengths may vary depending on machine type, therefore check measurements and number before ordering spare parts.

Spare part list - Hydraulics

Support for accumulator

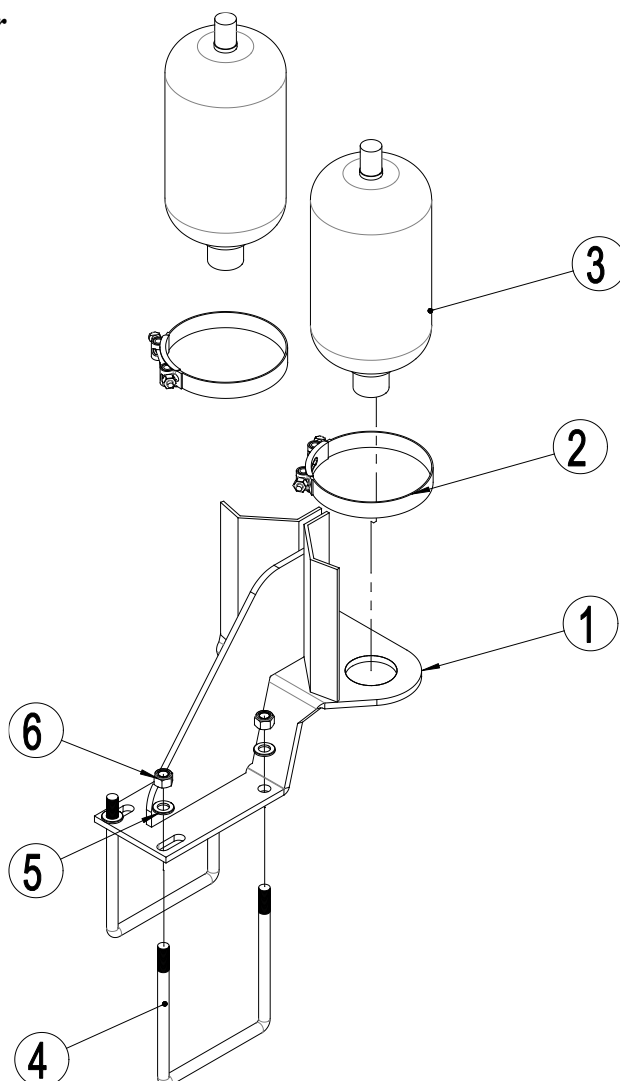

Pos.	Item no.	Designation	No.
1	645000125	Bracket for accumulator	1
2	690206516	Clamp 175-187 mm.	2
3	690206513	Accumulator 4,5L 90 bar	2
4	690110109	U-bolt M16x180x180x180	2
5	0272290	Facet plate Ø16	4
6	0264090	Self-locking nut M16	4

Hydraulics for roller depth control

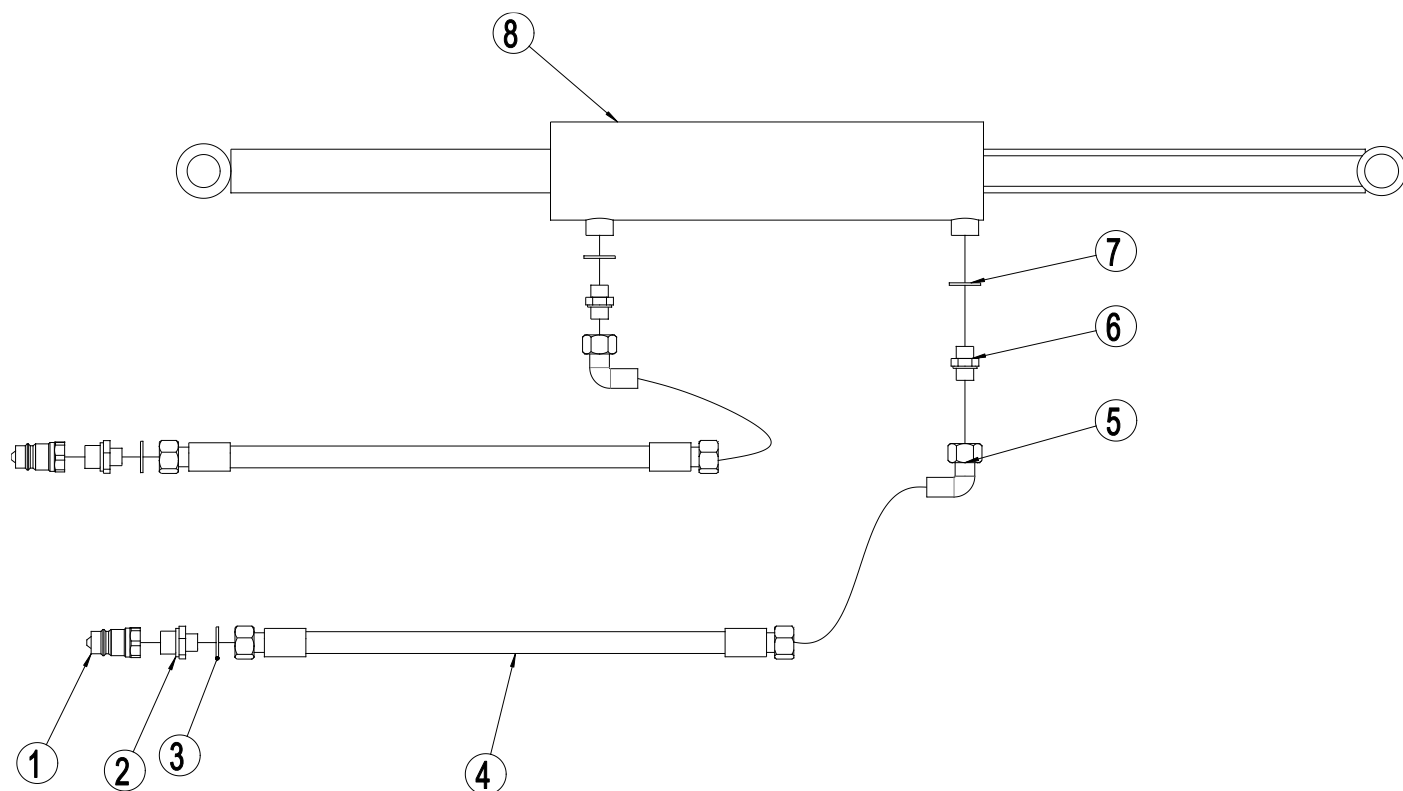

Pos.	Item no.	Designation	2,5m	3,0m	3,5m
1	690203001	Quick coupling E402 ½" male	2	2	2
2	690203003	Fitting, straight 10-½" BSP	2	2	2
3	0449070	Bonded seal ½"	2	2	2
4	0454645	Hydraulic hose 2300mm ¼"	2	2	2
5	0446678	Fitting, 90-angle Ø10x¾"	2	2	2
6	690203002	Fitting Ø10x¾"	2	2	2
7	0449060	Bonded seal ¾"	2	2	2
8		See pos. 10, page 16	1	1	1

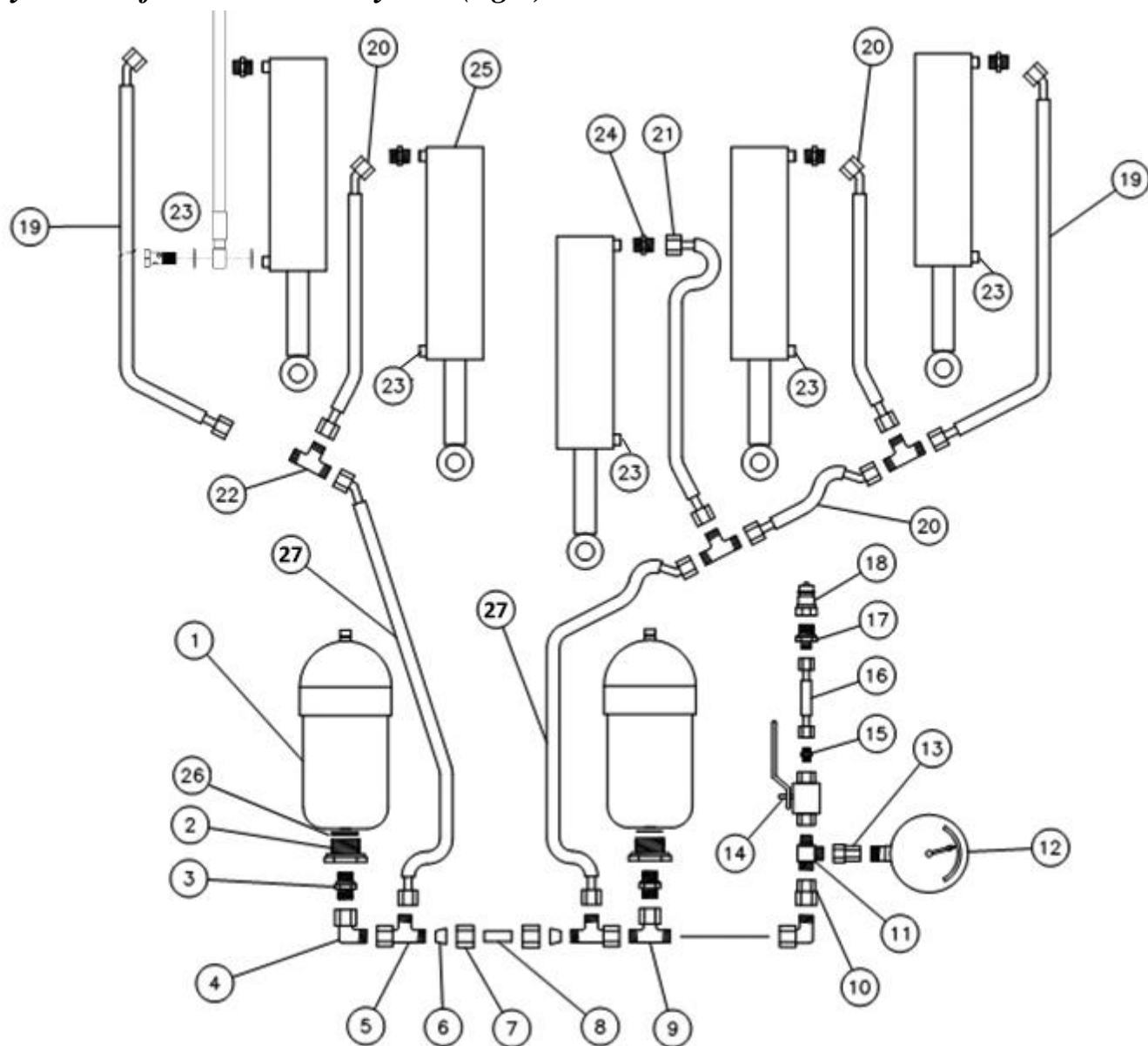
Hydraulics for auto-release system (rigid)

Pos.	Item no.	Designation	No.
1	690206513	Accumulator 4,5L 90 bar	2
2	690204501	Fitting, straight 1/2" x 1 1/4"	2
3	0446757	Fitting, straight Ø15 mm x 1/2"	2
4	0446680	Fitting, 90-angle Ø15 mm w/pre-mounted union nut	2
5	0446500	Fitting, T Ø15L	2
6	690204503	Olive ring Ø15	2
7	690204504	Union nut Ø15	2
8	662000803	Hydraulic tube Ø15 L=38	1
9	690204505	Fitting, T Ø15	1
10	0447710	Reversed fitting Ø15 / 1/2"	1

Pos.	Item no.	Designation	No.
11	690203314	Fitting, T $\frac{3}{8}$ "-Ø12-Ø12	1
12	0442051	Pressure gauge 400 bar	1
13	690206825	Fitting for pressure gauge Ø12 / $\frac{1}{4}$ "	1
14	0442350	Ball valve $\frac{3}{8}$ " PN500 DN 10	1
15	690203002	Fitting, straight Ø10- $\frac{3}{8}$ " BSP	1
16	0454313	Hydraulic hose 1130 mm $\frac{1}{4}$ " st/st	1
17	690203003	Fitting, straight Ø10- $\frac{1}{2}$ " BSP	1
18	690203001	Quick coupling $\frac{1}{2}$ " E402, male	1
19	690201448	Hydraulic hose 1150 mm $\frac{1}{2}$ " st/45°	2
20	690201430	Hydraulic hose 590 mm $\frac{1}{2}$ " st/45°	0-7
21	690201414	Hydraulic hose 400 mm $\frac{1}{2}$ " st/st	0-1
22	690204507	Fitting, T Ø15	0-5
23	0451700	Hydraulic hose 1500 mm $\frac{1}{4}$ " w/banjo fitting	2-5
23a	0444950	Banjo bolt $\frac{1}{4}$ "	2-5
23b	0449050	Bonded seal, PP45B	4-10
24	0446757	Fitting, straight Ø15x $\frac{1}{2}$ "	2-5
25		See pos 2, page 20	2-5
25a	690200313	Gasket set	
26	0449110	Bounded seal 1 $\frac{1}{4}$ "	2
27	0454183	Hydraulic hose 600 mm $\frac{1}{2}$ " st/st	2

Attention: The number of hoses and hose lengths may vary depending on machine type, therefore check measurements and number before ordering spare parts.

Notes

Maskiner til vækst
Maskiner til vækst
Maskiner til vækst
Maskiner til vækst
Maskiner til vækst
Maskiner til vækst
Maskiner til vækst



The design is subject to modification without notice.