



UK

*Operating Instructions
Declaration of Conformity
Spare Parts List*

*Disc-Roller
4,0 – 5,0m (2-section)*



Important: Before using the machine, please study the Operating Instructions thoroughly to ensure that you are familiar with the safety instructions.



N. A. Christensensvej 34
DK-7900 Nykøbing Mors
Tel: +45 9772 4288
Fax: +45 9772 2112
www.he-va.com

Contents

EC DECLARATION OF CONFORMITY	3
SAFETY INSTRUCTIONS FOR DISCROLLER	4
SAFETY AND INSTRUCTIONS ON HYDRAULICS	5
LABELS ON THE MACHINE.....	6
<i>SAFETY – AND OTHER MARKINGS ON THE MACHINE.....</i>	<i>6</i>
TECHNICAL SPECIFICATIONS / DATA	7
START-UP OF THE MACHINE	9
<i>ATTACHMENT, MOUNTED MODEL.....</i>	<i>9</i>
<i>ATTACHMENT, TRAILED MODEL</i>	<i>9</i>
TRANSPORT POSITION TO WORKPOSITION	10
<i>UNCOUPLING, MOUNTED MODEL.....</i>	<i>10</i>
<i>UNCOUPLING, TRAILED MODEL</i>	<i>10</i>
SETTINGS AND ADJUSTMENTS	11
<i>DRAWBAR</i>	<i>11</i>
<i>DISC.....</i>	<i>11</i>
<i>EDGE EQUIPMENT</i>	<i>12</i>
<i>EDGE EQUIPMENT FROM MACHINE NO. 341738.....</i>	<i>13</i>
<i>SCRAPER.....</i>	<i>14</i>
<i>SCRAPER FROM 2009 UNTIL MACHIN NO. 344861:.....</i>	<i>14</i>
<i>MATERIAL DAMPER GUARD.....</i>	<i>15</i>
<i>TINE ERADICATOR SET (CAN ONLY BE MOUNTED ON TRAILED MODELS).....</i>	<i>15</i>
MAINTENANCE AND SERVICE.....	16
SPARE PARTS LIST	17
<i>DRAWBAR (FOR TRAILED MODELS)</i>	<i>17</i>
<i>CENTRE SECTION.....</i>	<i>19</i>
<i>WHEEL ASSEMBLY (FOR TRAILED MODELS)</i>	<i>21</i>
<i>SIDE SECTION.....</i>	<i>23</i>
<i>DISC.....</i>	<i>25</i>
<i>PACKINGROLLER</i>	<i>27</i>
<i>SCRAPER.....</i>	<i>28</i>
<i>SCRAPER FROM 2009 UNTIL MACHINE. 344861</i>	<i>30</i>
<i>EDGE EQUIPMENT</i>	<i>31</i>
<i>EDGE EQUIPMENT FROM MACHIN NUMBER 341738.....</i>	<i>33</i>
SPARE PARTS LIST - EXTRA EQUIPMENT.....	35
<i>MATERIAL DAMPER GUARD.....</i>	<i>35</i>
<i>SPRING-BOARD (LEFT) 4,0 – 5,0M</i>	<i>37</i>
<i>EL. DEPTH STOP F/DISC.....</i>	<i>40</i>
<i>LIGHTS</i>	<i>43</i>
<i>HYDRAULIC BRAKES.....</i>	<i>45</i>
<i>AIR BRAKES.....</i>	<i>46</i>
<i>TINE ERADICATOR SET.....</i>	<i>48</i>
<i>SUPPORTING WHEEL (MODEL FOR SPRING-BOARD).....</i>	<i>49</i>
<i>SUPPORTING WHEEL (MODEL WITHOUT SPRING-BOARD).....</i>	<i>51</i>
SPARE PARTS LIST - HYDRAULICS	53
<i>HYDRAULICS BETWEEN DRAWBAR AND WHEEL FRAME.....</i>	<i>53</i>
<i>HYDRAULICS FOR FOLDING UP OF SIDE SECTIONS</i>	<i>54</i>
<i>HYDRAULICS FOR ADJUSTMENT OF DISC</i>	<i>56</i>
DIAGRAMS	58
<i>EL. DEPTH STOP</i>	<i>58</i>
<i>LIGHTS</i>	<i>59</i>
<i>HYDRAULICS</i>	<i>60</i>
<i>HYDRAULICS F/DEPTH STOP</i>	<i>61</i>
<i>HYDRAULICS F/EL. DEPTH STOP.....</i>	<i>61</i>
NOTES:.....	62



EC DECLARATION OF CONFORMITY

in accordance with the EU Machinery Directive 2006/42/EC
applicable as from December 29th 2009:

HE-VA ApS
N. A. Christensensvej 34,
DK-7900 Nykøbing Mors

hereby confirms that the following machine has been manufactured in accordance with the Council
Directive 2006/42/EC.

The declaration comprises the following machine:

Disc-Roller 4.0m – 5.0m

Nykøbing the 29th December 2009

Villy Christiansen

The undersigned is furthermore authorised to compile technical documentation for the above
machine.

Safety Instructions for DiscRoller

Do not start-up the machine if there are persons in exposed positions** within a hazardous area*.

When persons are in exposed positions (e.g. in connection with adjustment, maintenance, attachment and uncoupling), the following conditions must be observed:

1. The machine must be lowered to firm ground.
2. The hydraulics must be relieved.
3. The tractor must be stopped and the key removed from the ignition switch.
4. The driver must ensure that no persons are staying in exposed positions during the operation.

* Hazardous area: On and under the machine within a distance of 4 m from the machine.

** Person in exposed position: Any person who is staying wholly or partly within a hazardous area.

Most accidents that happen in connection with the operation, transport and maintenance of machines are caused by non-compliance with the most elementary safety conditions.

Therefore it is vital that anybody working at the machine carefully complies with the safety instructions as well as other instructions applying to the machine.

The machine may only be operated, maintained and repaired by persons, who are familiar with this work and who are further familiar with the possible elements of danger with this particular machine.

Instructions on Unloading and Placing

The machine is supplied completely assembled by our lorry. Our specially trained drivers will assist in the unloading of the machine.

The machine must be driven from the lorry by means of a tractor on the ramps provided and according to our driver's instructions.

Afterwards place the machine on level and firm ground.

ATTENTION !! Rotary parts and loose clothes are a dangerous combination.

IMPORTANT !! In connection with the risk of parts falling down, it may endanger the lives of persons staying on the base frame of the machine, when it is operated attached to a tractor.

Safety and Instructions on Hydraulics

1. The maximum working pressure is 225 bar.
2. It is advisable to label the attachment parts at hydraulic connections between the tractor and the tool in order to eliminate incorrect operation!
3. When checking for hydraulic leaks, use suitable safety wear (eye protectors, gloves, etc.)
High-pressure hydraulic oil may penetrate the skin and cause dangerous injuries.
In case of injury, consult a doctor immediately. **RISK OF INFECTION!**
5. After operating the hydraulics, lower the machine to firm ground.
Relieve the hydraulics, stop the motor and remove the ignition key.
6. Check the hydraulic hoses on a regular basis, however, every six months as a minimum due to any cracks, wear and tear, etc. Replace any defective hoses immediately.

The life of hydraulic hoses is maximum 5 years.

New hydraulic hoses must meet the manufacturer's requirements.

INSTRUCTIONS ON TRANSPORT ON THE PUBLIC ROADS

Check before transport on public roads that the attachment of the machine at the tractor is in accordance with the local rules and regulations in force (permitted total weight, permitted axle load, transport width, lights, warning signs, etc.).

FRONT AXLE LOAD

After the attachment of the machine and at maximum load, the driving properties of the tractor must be ensured. Check that the front axle is sufficiently loaded. As a minimum, the front axle load must be 20% of the tractor weight. Permitted axle load and permitted total weight for the tractor must always be observed.

NB! The driving, controlling and braking properties are affected by the attached machine combination.

Labels on the machine

You will find several labels on your Disc-Roller containing **safety** and practical instructions as regards the correct application of the machine. Please study the instructions and point out to the user the importance of the labels as well as the **safety instructions** in these Operating Instructions. Always keep the labels clean and readable – if not they must be replaced.

Safety – and other markings on the machine

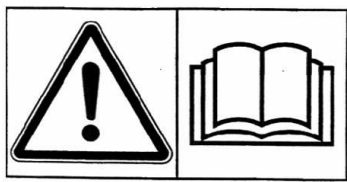

Study the Operating Instructions thoroughly before any operation of the machine and observe all safety instructions.

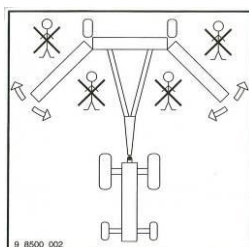

Take care that no persons are within the machine's hazardous area during the unfolding and folding procedure..



Plate with number and year of manufacture



Tighten up the bolts regularly. If this is not performed, our warranty obligations will no longer apply.

Maximum torque in Nm. w/lubricated thread			
Metric thread	Quality 8.8	Quality 10.9	Quality 12.9
M12	81	114	136
M14	128	181	217
M16	197	277	333
M18	275	386	463
M20	385	541	649
M22	518	728	874
M24	665	935	1120

Technical Specifications / Data

Mounted Disc Roller 4.0m and 5.0m with Ø510 mm disc and Ø600 mm profile rings

	<u>4,0m</u>	<u>5,0m</u>
Working width:	4,0m	5,0m
Transport width:	2,45m	2,45m
Machine length:	2,30m	2,30m
No of Discs:	30	38
Weight with V-profile rings:	3120 kg	3750 kg
No of V-profile rings:	32	40
No. of scrapers (V-rings):	31	39
Weight with T-profile rings:	2760 kg	3290 kg
No. of T-profile rings:	32	40
No of scrapers (T-rings):	31	39
No. of hydraulic outlets:	2 double-acting	
Hydraulic pressure (min.):	190 bar	
Max. working depth:	12 cm	
Working speed (recommended):	10 – 16 km/h	

**Trailed Disc Roller 4.0m and 5.0m
with Ø510 mm disc
and Ø600 mm profile rings**

	<u>4,0m</u>	<u>5,0m</u>
Working width:	4,0m	5,0m
Transport width:	2,45m	2,45m
Machine length:	5,60m	5,60m
No. of Discs:	30	38
Weight with V-profile rings:	3680 kg	4300 kg
No. of V-profile rings:	32	40
No. of scrapers (V-rings):	31	39
Weight with T-profile rings:	3320 kg	3850 kg
No of T- profile rings:	32	40
No. of scrapers (T-rings):	31	39
No. of hydraulic outlets:	3 double-acting	
Hydraulic pressure (min.):	190 bar	
Wheels:	400/60 x 15,5 – 14 PLY	
Wheel pressure at 15 km/h:	2,1 bar / 30 p.s.i	
Wheel pressure at 40 km/h:	3,5 bar / 50 p.s.i	
Max. working depth:	12 cm	
Working speed (recommended):	10 – 16 km/h	

Start-up of the machine

General Information

The machine is supplied as standard in transport position. At start-up, attach the machine to the tractor.

Important:

Check that the towing hook height is between 400 and 500 mm.
Check that the male quick-couplings of the Disc-Roller fit the female quick-couplings of the tractor.

The machine requires two double-acting outlets (mounted) or three double-acting outlets (trailed).

The hoses for the drawbar - / wheel cylinder are provided with **red** cable straps.

The hoses for the folding cylinder are provided with **blue** cable straps.

The hoses for the disc cylinder are provided with **green** cable straps.

Attachment, Mounted Model

1. Reverse the tractor to the machine and attach.
2. Connect all hydraulic hoses to the tractor outlets.
3. Lift the machine to maximum transport height.
4. Fold up the side sections (blue) towards the stop on the centre frame.
5. When the side sections are unfolded, open the locking claws first and after that the side sections will unfold.
6. When the side sections are completely unfolded, let go of the hydraulic handle and the machine is ready for use.
7. Unfold the edge equipment to working position.
8. Now lift and lower the discs to the required working depth.

Attachment, Trailed Model

1. Reverse the tractor to the machine.
2. Connect all hydraulic hoses to the tractor outlets.
3. Pressurise the drawbar - and the wheel cylinder (red) so that the machine drawbar is lifted to the suitable height.
4. Then reverse the tractor and attach the machine.
5. Now lift the machine to maximum height and tilt the depth stop backwards towards the drawbar cylinder.
6. Fold up the side sections (blue) towards the stop on the centre frame.
7. When the side sections are unfolded, open the locking claws first and after that the side sections will unfold.
8. When the side sections are completely unfolded, let go of the hydraulic handle and the machine is ready for use.
9. Unfold the edge equipment to working position.
10. Now lift and lower the discs to the required working depth.

Transport position to workposition

1. **Important: When unfolding the side sections, the locking claw must first be relieved by activating the folding function, until the side sections meet the stop at the center frame.** Next, when the unfolding function is activated, the locking claw then first will open, after which the side sections are unfolding.
2. When the side sections are completely unfolded, let go of the hydraulic handle and the machine is ready for use.
Always set the tractor's flow control on MAX, to make sure that the side sections will follow each other.
3. Unfold the edge equipment to working position.
4. Now lift and lower the discs to the required working depth.

Transport

1. Lift the discs to the top before folding up the machine.
2. Then lift the machine to maximum transport height.
3. Now pressurise the folding cylinders and the side sections will be folded up. After that put the function in floating position, however, ensure that the locking claws have locked the side sections.
4. Now the machine is secured and ready for transport.
5. Lower the machine in order to minimise the transport height, to obtain a center of gravity as low as possible. It is recommendable to drive slowly and carefully in turns and roundabouts.

Uncoupling, Mounted Model

1. Put down the machine on firm ground and relieve all hydraulic hoses.
2. Now the machine may be uncoupled.

Uncoupling, Trailed Model

1. Lift the machine up and tilt the depth stop on the drawbar forward towards the tractor.
2. Now lower the machine onto firm ground.
3. Adjust the drawbar – and wheel cylinder (red) so that the drawing bolt is loose.
4. Now the machine may be uncoupled.
5. Drive the tractor a little forward and then relieve all hydraulic hoses.

Important:

Put the machine on level ground and relieve the hydraulics, before leaving the machine.



Settings and adjustments

When starting-up the Disc-Roller in the field, it is very important that the machine is parallel with the surface of the earth. The packing roller and the tractor keep the machine in an exact working depth.

Drawbar

It is important that the top link (mounted model) or the 2 adjusting bolts (A) on the drawbar (trailed model) are adjusted correctly.

Drawbar height (recommended): approx. 500mm.

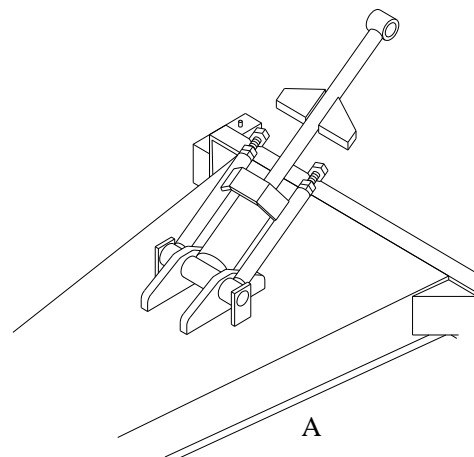

Disc

The Discs are adjusted up or down by a hydraulic Master-Slave system.

It is important that the discs are regularly lifted to the top to reset the Master-Slave system.

The depth position is readable on the scale (standard).

The sensor can be adjusted, where el. depth stop is mounted.

It is possible to over steer the electrical system by turning off the switch mounted in the cabin, now the discs can pass the sensor, thereby a deeper working depth is achieved e.g. at headland and tramlines.

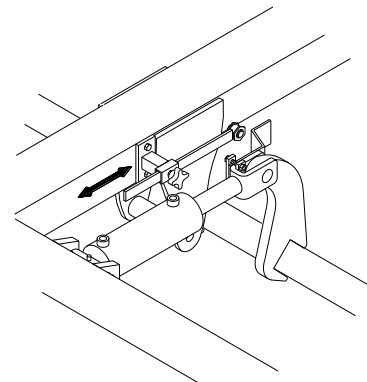

Edge equipment

Disc-Roller is standard equipped with edge equipment.
Adjust the edge plate (1), to keep the excavated soil in a row.
Keep the edge plate (1) away from the ground to avoid bending
when turning.

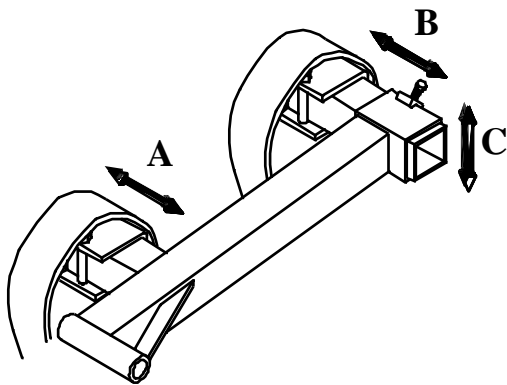
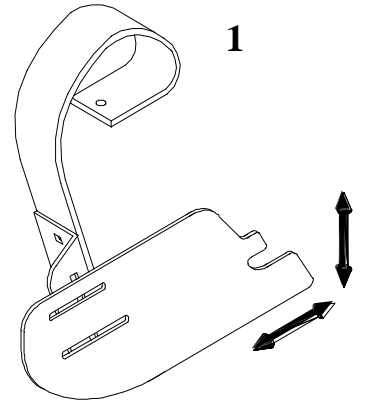

Adjust the tine for the edge plate (A), so that the material can pass the rear disc. Huge amounts of straw require greater space.

Depth stop for edge

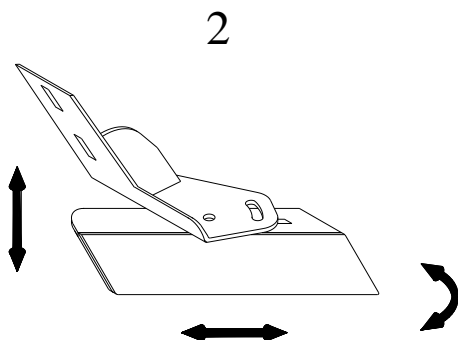
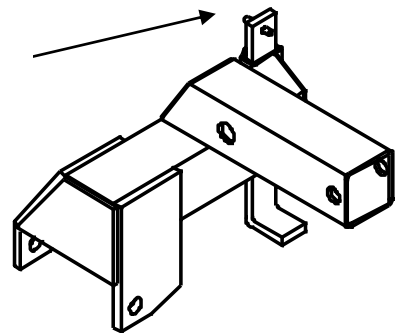

Adjust the edge plough (2) so that the material is placed in the “groove” formed by the rear disc.

Edge equipment from machine no. 341738

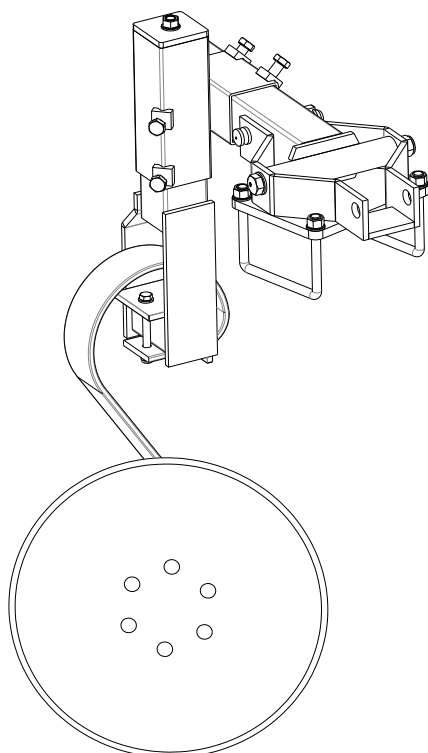

New edge equipment for Disc-Roller.

The disc can be adjusted so that the excavated soil is collected. Keep the disc away from the ground to avoid bending when turning.

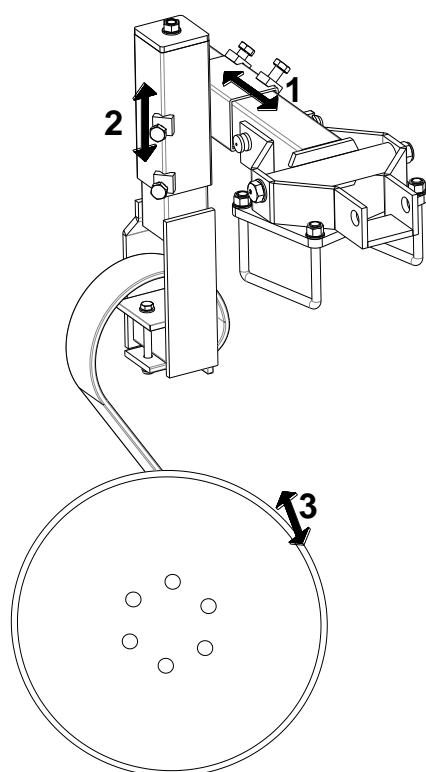

The edge equipment can be adjusted three places:

1. Loosen two bolts – move the arm out/in.
2. Use the spindle – it raises and lowers the disc. Loosen two bolts – raise/lower by the spindle and retighten the bolts.
3. Loosen one bolt – tilt the disc more or less.

Scraper

The Disc-Roller has special designed scrapers among the packer rings.

To avoid unnecessary wear and to obtain the best scraper effect it is important to check the centering of the scrapers every day.

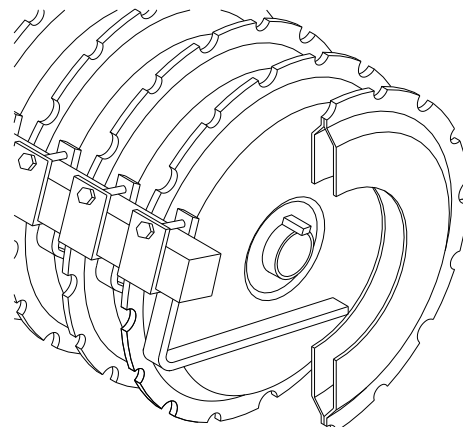
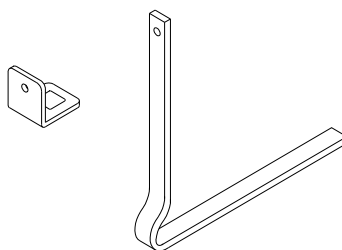

Scraper from 2009 until machin no. 344861:

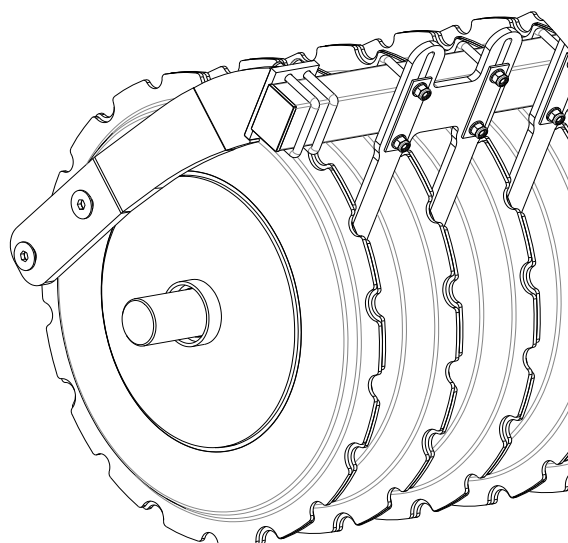
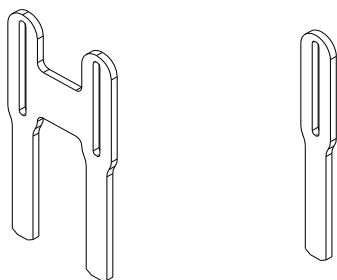

Material damper guard

The Disc-Roller can be equipped with material damper guard, ensuring that excavated soil from the discs is falling down before packing.

The material damper guard is height adjustable in 5 cm steps, by unlocking 1 pin in each bracket.

To dismount the material damper guard, unlock pins and unbolt.

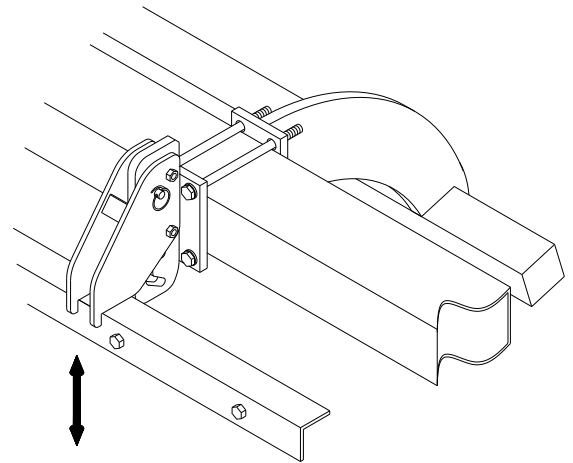

Tine eradicator set (can only be mounted on trailed models)

The trailed Disc-Roller can be equipped with tine eradicator set / track remover, which loosens the packed soil from the tractor wheels - ensuring a uniform preparation of the soil.

The equipment is height adjustable, by unlocking 1 pin in each tine.

To dismount the tine eradicator, unlock pins and unbolt.

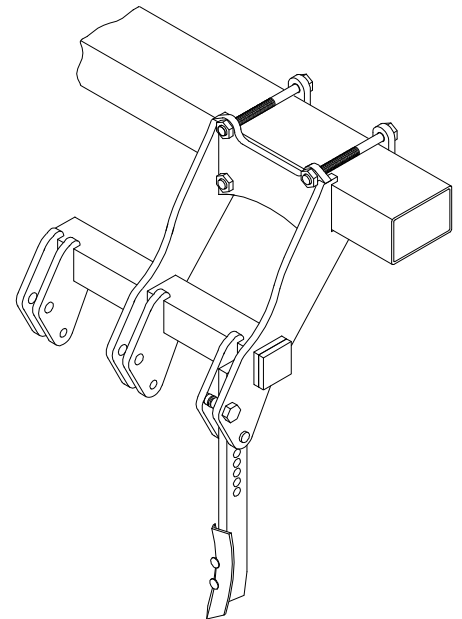

Maintenance and service

A. Grease hubs at the discs so that grease is appearing at the seals of the hubs.

Every 30 hours of operation grease again. If the machine is driving under difficult conditions (much dust), grease more often.

Important:

Grease hubs at the discs before wash,
to avoid water penetration into the bearings.
Grease piston rods.



B. After 10 hours of operation, retighten wheels, bearings and stop rings. Check hydraulic hoses, fittings and cylinders for leaks and retighten.

C. Every 10 hours of operation, grease all pivoting points in side sections, drawbar and wheel assembly.

D. After end season, grease and wash machine.

Important:

Oil, type Hydro Texaco HD 32 has been
filled in the hydraulic system.

Spare parts list

Drawbar (for trailed models)

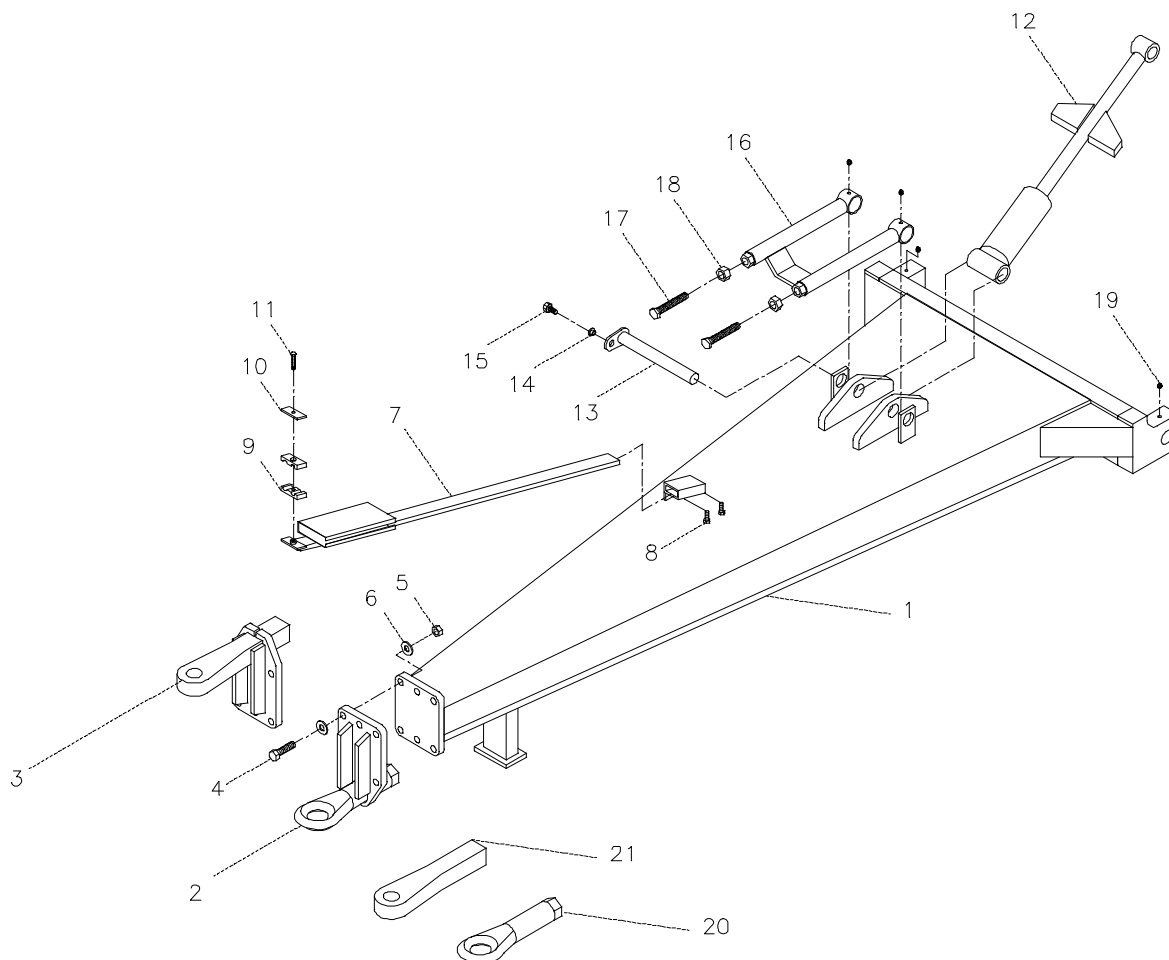

Pos.	Item no.	Designation		4,0 m	5,0 m
1	30931000	Main frame - drawbar	until february 2010	1	1
1a	630931000	Main frame - drawbar	after february 2010	1	1
2	630931035	Front drawbar (turnable)	until february 2010	1	1
2a	630757028	Front drawbar (turnable)	after february 2010	1	1
3	630931037	Front drawbar (riged)	until february 2010	1	1
3a	630757013	Front drawbar (riged)	after february 2010	1	1
4	690103130	Bolt M16x70 10.9		6	6
5	690113008	Self-locking nut M16		6	6
6	690117013	Facet plate Ø16		12	12

Pos.	Item no.	Designation	4,0 m	5,0 m
7	630771200	Parking device f/hose on drawbar	1	1
8	690103075	Bolt M10x25	2	2
9	690210210	Tube-support double Ø14/Ø14	4	4
10	690210211	Top plate f/double tube-support	2	2
11	690103054	Bolt M8x40	2	2
12	630931026	Cylinder 80/40x155 w/ stop bracket	1	1
12e	690200138	Gasket set 80/40	1	1
13	69435250G	Pin Ø35 L=250	1	1
14	630532600	Lock bush f/pin head	1	1
15	690101101	Bolt M12x25	1	1
16	630931030	Depth stop f/drawbar	1	1
17	690103184	Bolt M20 x 80 (set screw)	2	2
18	690112009	Nut M20	2	2
19	690136029	Lubricating nipple M8	4	4
20	690141211	Towing eye (turnable)	1	1
21	690105003	Towing eye (fixed)	1	1

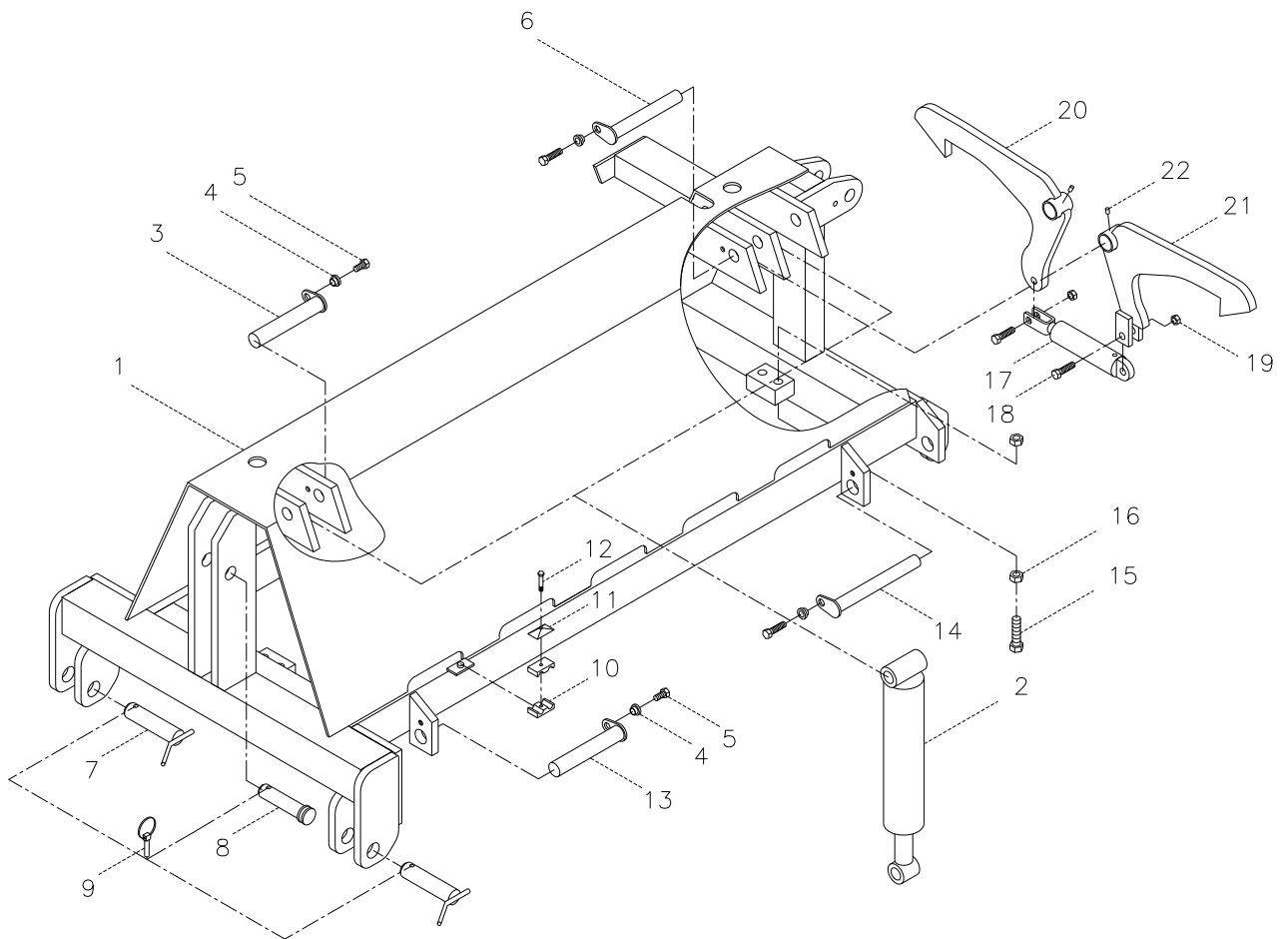
Centre section

Pos.	Item no.	Designation	4,0 m	5,0 m
1	630932000	Housing f/centre section	1	1
2	690200200	Cylinder 80/40x280	4	4
2e	690200138	Gasket set 80/40	4	4
3	69430145G	Pin Ø30 L=145	2	2
4	630532600	Lock bush f/pin head	8	8
5	690101101	Bolt M12x25	8	8
6	69430212G	Pin Ø30 L=212	2	2
7	69537129B	Pin for lift arm Ø37 L=129 (Cat. III)	2	2
8	69532100J	Pin for top link Ø32 L=100 (Cat. III)	1	1
9	690134004	Ring pin Ø10	3	3
10	690210210	Support-tube double Ø14/Ø14	4	4
11	690210211	Top plate f/double support-tube	2	2
12	690103054	Bolt M8x40	2	2
13	69435202G	Pin Ø35 L=202	2	2

Pos.	Item no.	Designation	4,0 m	5,0 m
14	69435258G	Pin Ø35 L=258	2	2
15	690103186	Bolt M20x100 (set screw)	4	4
16	690112009	Nut M20	8	8
17	690200170	Cylinder 40/25x80	1	1
17a	690200175	Gasket set 40/25	1	1
18	690103130	Bolt M16x70	2	2
19	690113008	Self-locking nut M16	2	2
20	630922160	Locking claw (right)	1	1
21	630922161	Locking claw (left)	1	1
22	690136029	Lubricating nipple M8	10	10

Wheel assembly (for trailed models)

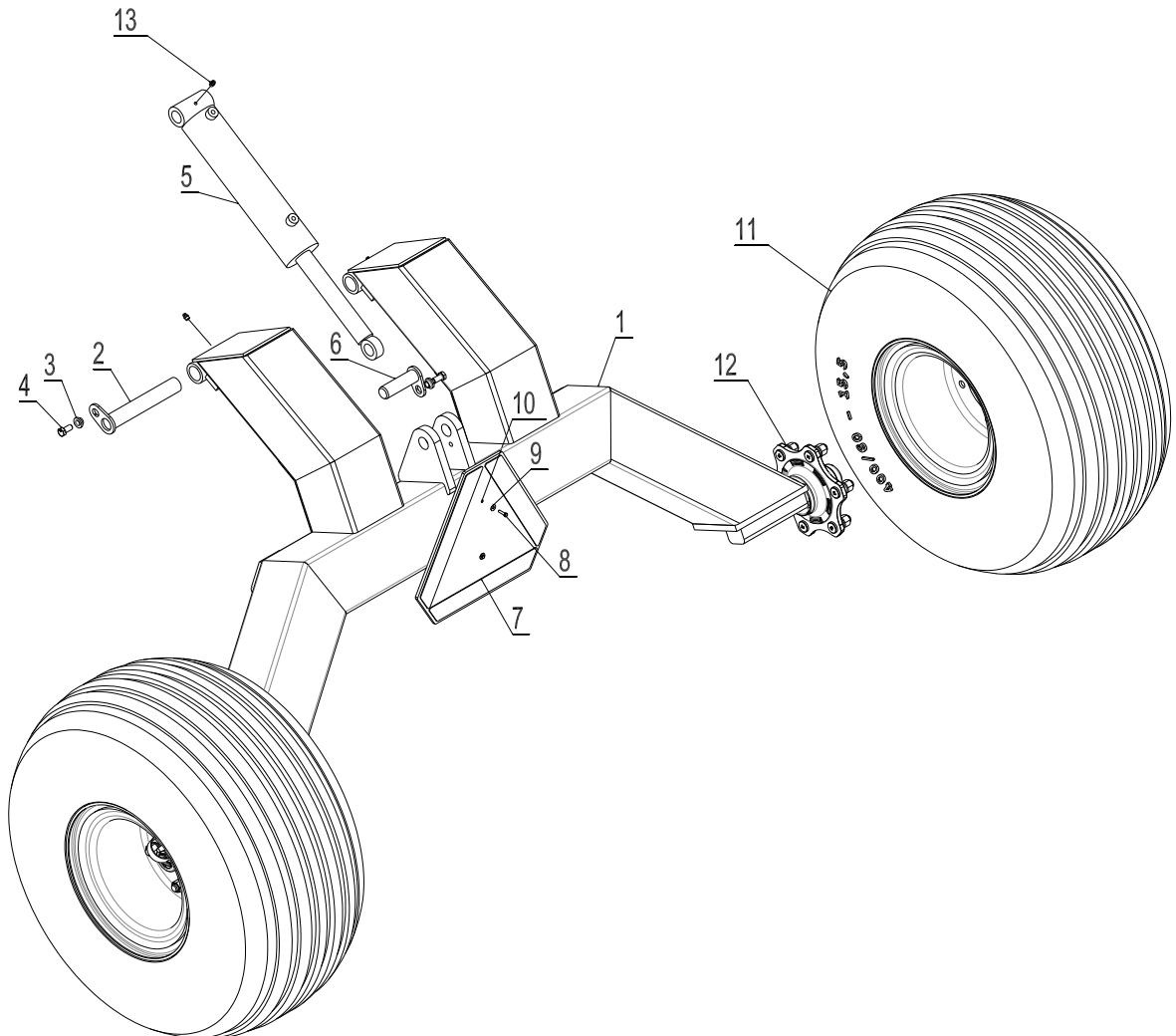

Pos.	Item no.	Designation	4,0 m	5,0 m
1	630935000	Wheel frame	1	1
2	69435220G	Pin Ø35 L=220	2	2
3	630532600	Lock bush f/pin head	4	4
4	690101101	Bolt M12x25	4	4
5	690200085	Cylinder 80/40x255	1	1
5e	690200138	Gasket set 80/40	1	1
6	69430100G	Pin Ø30 L=100	2	2
7	690142001	Warning triangle SMW	1	1

Pos.	Item no.	Designation	4,0 m	5,0 m
8	690103014	Bolt M5x20	2	2
9	690117002	Facet plate Ø5	2	2
10	690113002	Self-locking nut M5	2	2
11	690141335	Wheel 400/60 x 15,5 – 14 PLY	2	2
12	690141025	Hub 1700 kg	2	2
12	690141031	Hub w/brake 2500 kg	2	2
12a	690141039	Hub bolt M18 x 1.5 x 49	12	12
12b	690141055	Hub nut M18	12	12
12f	690141314	Hub cap ø62	2	2
12f	690141033	Hub cap ø80 (hub w/brake)	2	2
13	630136029	Lubricating nipple M8	2	2

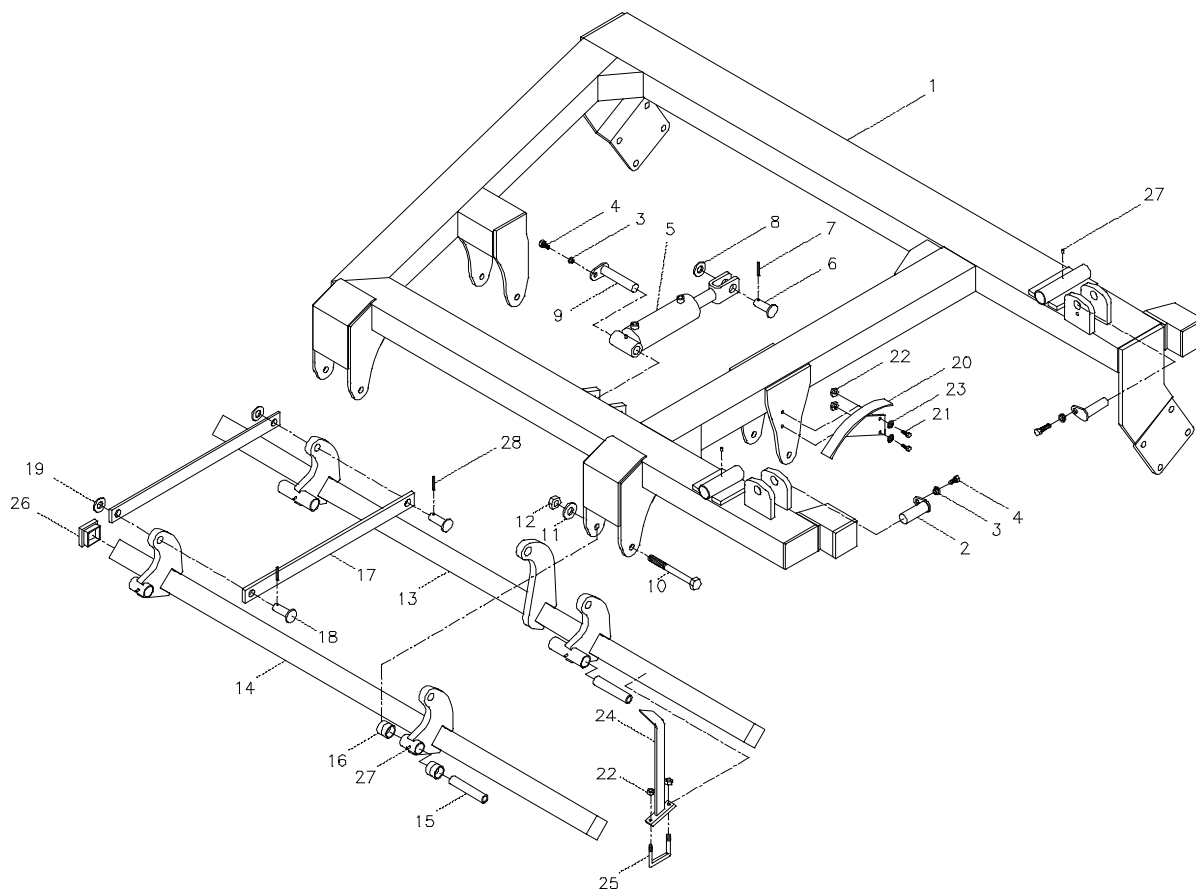
Side section

Pos.	Item no.	Designation	4,0 m	5,0 m
1	630924000	Main frame - side section (right)	1	0
1	630924100	Main frame - side section (left)	1	0
1	630934000	Main frame - side section (right)	0	1
1	630934100	Main frame - side section (left)	0	1
2	69430100G	Pin Ø30 L=100	4	4
3	630532600	Lock bush f/pin head	6	6
4	690101101	Bolt M12x25	6	6
5	690200640	Cylinder 85/30x155mm (right)	1	1
5a	690200641	Gasket set 85/30		
5	690200620	Cylinder 80/30x155 mm (left)	1	1
5a	690200621	Gasket set 80/30		
	630949041	Repair kit of valve in the cylinder		
6	69530060F	Pin Ø30 L=58	2	2

Pos.	Item no.	Designation	4,0 m	5,0 m
7	690130134	Roll pin Ø6x50	2	2
8	690115014	Facet plate Ø30	2	2
9	69430145G	Pin Ø30 L=145	2	2
10	690103172	Bolt M20 x 200	8	8
11	690117005	Facet plate Ø20	8	8
12	690113009	Self-locking nut M20	8	8
13	630929111	Bar in the rear (right)	1	0
13	630929114	Bar in the rear (left)	1	0
13	630939111	Bar in the rear (right)	0	1
13	630939114	Bar in the rear (left)	0	1
14	630929101	Bar in front (right)	1	0
14	630929104	Bar in front (left)	1	0
14	630939101	Bar in front (right)	0	1
14	630939104	Bar in front (left)	0	1
15	630929130	BK-tube Ø30x5 L=148	8	8
16	630949078	Bush L=20	16	16
17	630949077	Bar: parallel movement of bars	8	8
18	69525061F	Pin Ø25 L=58	8	8
19	690117021	Facet plate Ø27	8	8
20	630933260	Scale f/depth control	1	1
21	690101079	Bolt M10x25	2	2
22	690113005	Self-locking nut M10	4	4
23	690117012	Facet plate Ø10	4	4
24	630933264	Pointer for depth control	1	1
25	690110020	U-bolt M10x70x70x70	1	1
26	690109200	Plastic plug 60x60	8	8
27	690136029	Lubricating nipple M8	12	12
28	690130132	Roll pin Ø6x40	8	8

Disc

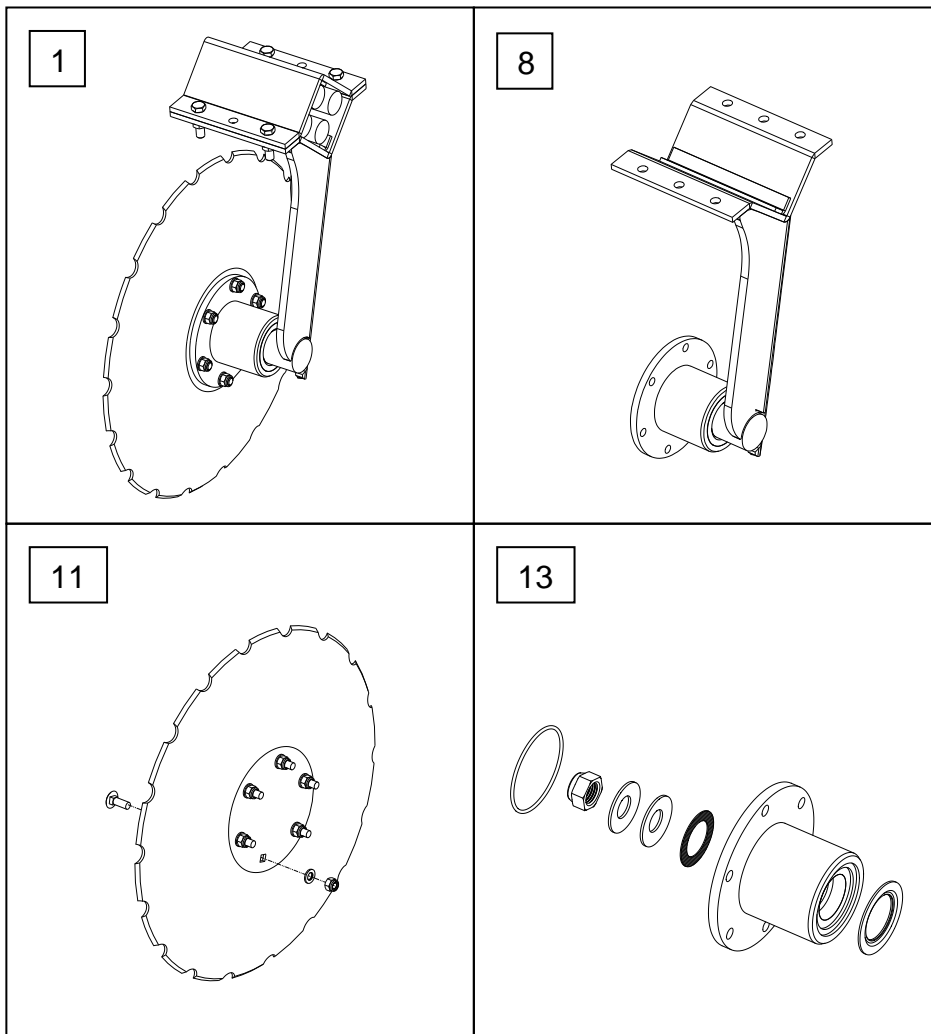
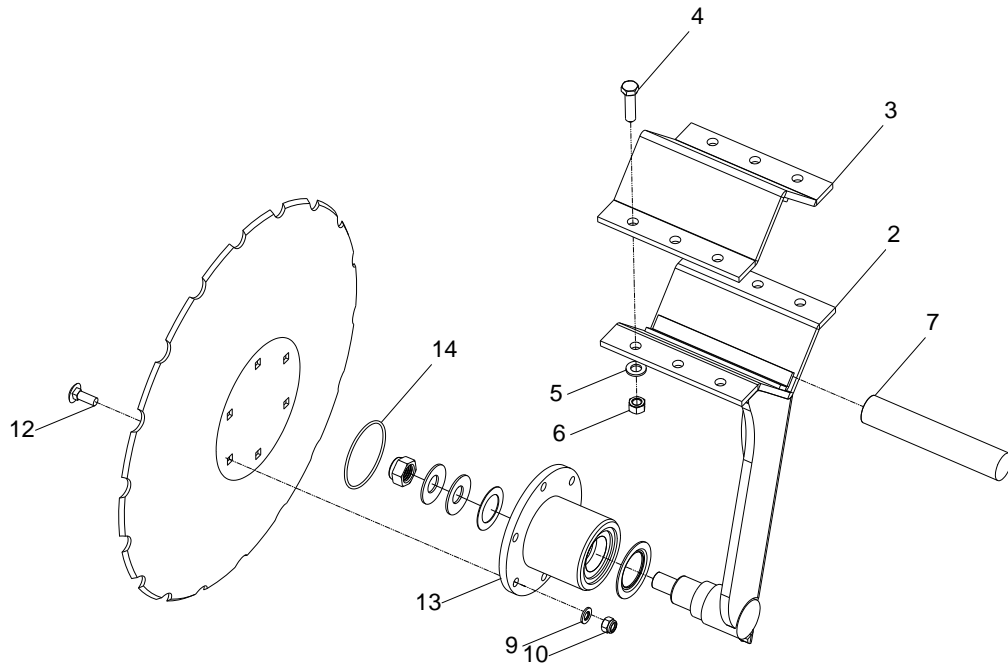

Pos.	Item no.	Designation	4,0 m	5,0 m
1	630949022	Complete disc (left) (front bar)		
1	630949012	Complete disc (right)(rear bar)		
2	630949026	Carrier arm (left)	15	19
2	630949016	Carrier arm (right)	15	19
3	630949046	Clamping plate for carrier arm	30	38
4	690103091	Bolt M12x45 10.9	120	152
5	690117014	Facet plate Ø12	120	152
6	690113013	Self-locking nut M12 (all-metal)	120	152
7	690210710	Rubber cord Ø35 L=205	120	152
8	630949025	Complete Carrier arm (left) (front bar)	15	19
8	630949015	Complete Carrier arm (right) (rear bar)	15	19
9	690117012	Facet plate Ø10	180	228
10	690113005	Self-locking nut M10	180	228
11	690153508	Disc (scalloped Ø508 x 4mm w/6 holes and flat centre incl. bolts)	30	38
12	690101210	Bolt M10x30 (carrier bolt)	180	228
13	630949035	Repair outfit (with hub)		
13	630949032	Repair outfit (with hub) from machine number 344472		
14	690140910	O-Ring 80 x 3		

Packingroller

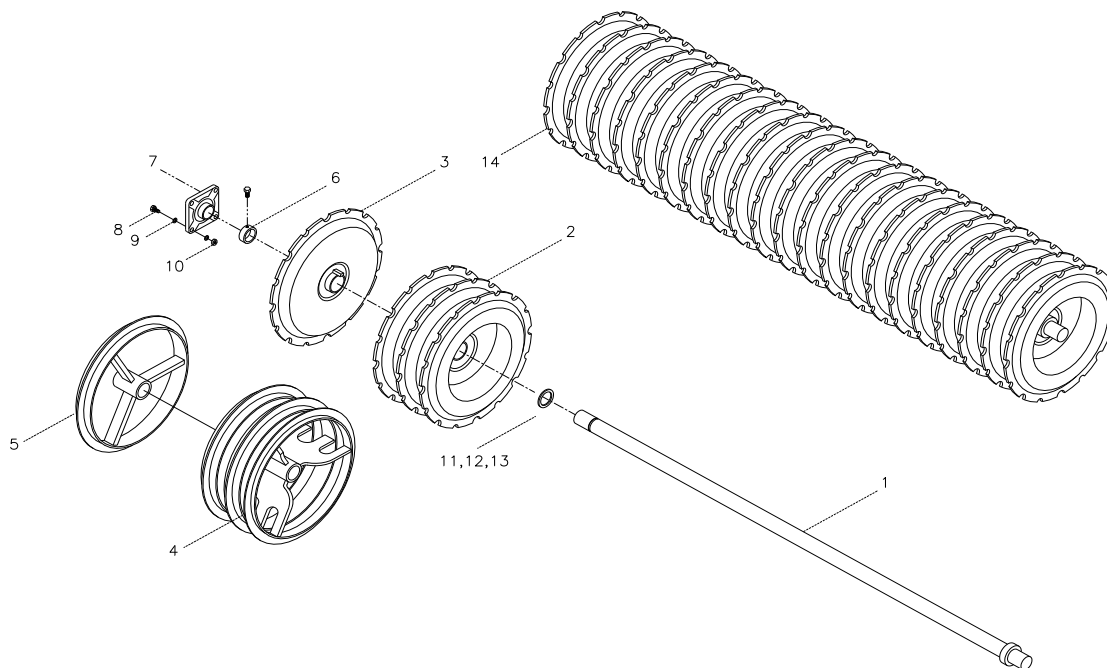

Pos.	Item no.	Designation	4,0 m	5,0 m
1	678601935	Axle 1935mm	2	0
1	678602435	Axle 2435mm	0	2
2	690150037	V-profile ring, triple, Ø600mm/ Ø60 mm	4	4
3	690150036	V-profile ring, single, Ø600mm/ Ø60 mm	20	28
4	690150058	T-profile ring, triple, Ø600mm/ Ø60 mm	4	4
5	690150056	T-profile ring, single, Ø600mm/ Ø60 mm	20	28
6	671040400	Stop ring w/bolts ø60	2	2
7	690140808	Ball bearing UCF 312, ø60, w/4 holes	4	4
8	690103147	Bolt M20x65	16	16
9	690117005	Facet plate Ø20	32	32
10	690113009	Self-locking nut M20	16	16
11	690117101	Shim Ø80x60,5x1mm		
12	690117102	Shim Ø80x60,5x2mm		
13	690117103	Shim Ø80x60,5x5mm		
14	630926301	Solid V-profil roller 1935mm	2	
14	1160479	Solid V-profil roller 1935mm from machine.: 344861	2	
14	630936300	Solid V-profil roller 2435mm		2
14	1160468	Solid V-profil roller 2435mm from machine.: 344861		2

Scraper

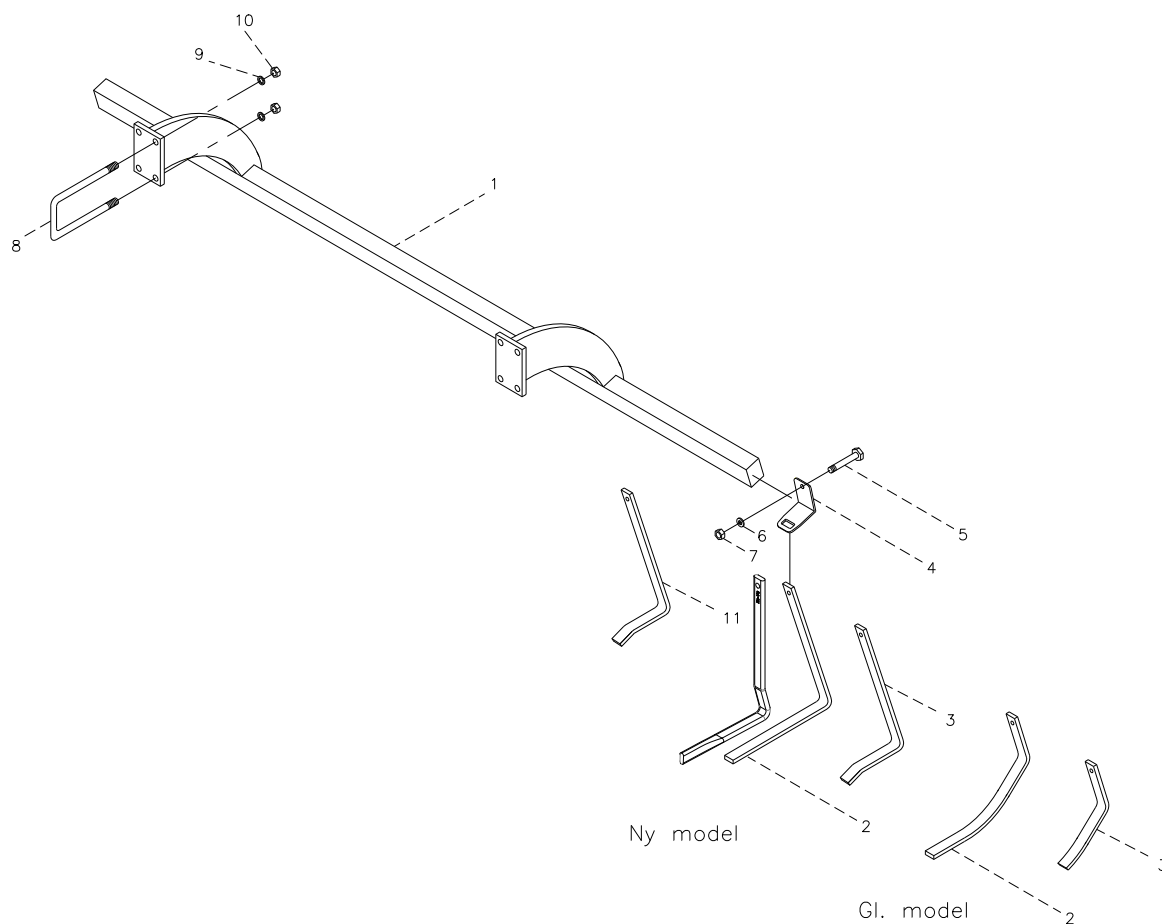

Pos.	Item no.	Designation	4,0 m	5,0 m
1	630928550	Scraper bar w/bracket	2	0
1	630928550	Scraper bar w/bracket (right) From machine no. 336262	1	0
1	630928560	Scraper bar w/bracket (left) From machine no. 336262	1	0
1	630938550	Scraper bar w/bracket	0	2
1	630938550	Scraper bar w/bracket (right) From machine no. 336262	0	1
1	630938560	Scraper bar w/bracket (left) From machine no. 336262	0	1
1	630938589	Scraper bar w/bracket (right) From machine no. 344861	1	
1	630938587	Scraper bar w/bracket (left) From machine no. 344861	1	
1	630938579	Scraper bar w/bracket (right) From machine no. 344861		1
1	630938578	Scraper bar w/bracket (left) From machine no. 344861		1
2	630938525	Scraper f/V-profile ring and T-profile ring (long)	27	35
2	630938523	Scraper f/V-profile ring and T-profile ring (long) From machine no. 336262	27	35

Pos.	Item no.	Designation	4,0 m	5,0 m
2	630938520	Scraper f/V-profile ring, twisted From machine no. 344861	27	35
3	630938527	Scraper f/V-profile ring and T-profile ring (short)	4	4
3	630938524	Scraper f/V-profile ring and T-profile ring (short) From machine no. 336262	4	4
4	690152030	Clamp	31	39
4	630938522	Clamp From machine no. 336262	31	39
5	690103098	Bolt M12x110	31	39
5	690103086	Bolt M12x90 From machine no. 336262	31	39
6	690117014	Facet plate Ø12	31	39
7	690113006	Self-locking nut M12	31	39
8	690110106	U-Bolt M16x200x100x200	8	8
9	690117013	Facet plate Ø16	16	16
10	690113008	Self-locking nut M16	16	16
11	690938526	Scraper f/ solid V-profile roller	27	35

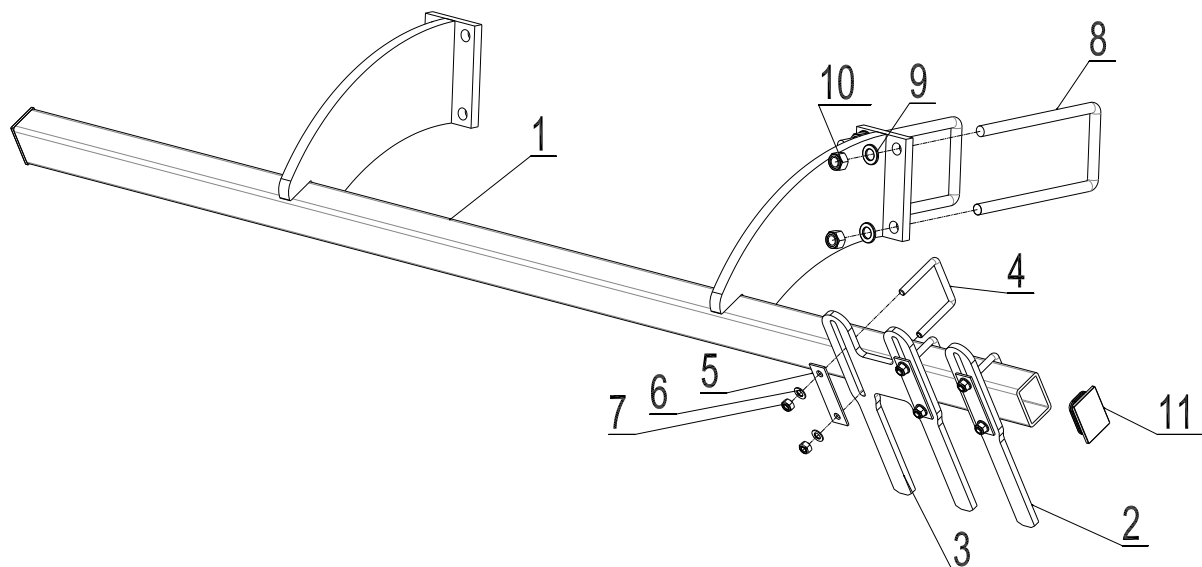
Scraper from 2009 until machine. 344861

Pos.	Varenr.	Betegnelse	4,0 m	5,0 m
1	630928565	Scraper bar w/bracket (left)	1	0
1	630928555	Scraper bar w/bracket (right)	1	0
1	630938565	Scraper bar w/bracket (left)	0	1
1	630938555	Scraper bar w/bracket (right)	0	1
2	630938505	Single scraper 2009	2	2
3	630938506	Double scraper 2009	14	18
4	690110025	U-Bolt M10 50x70x50	30	38
5	630938507	Clamp for scraper 2009	30	38
6	690117012	Facet plate Ø10	60	76
7	690113005	Self-locking nut M10	60	76
8	690110106	U-bolt M16x200x100x200	8	8
9	690117013	Facet plate Ø16	16	16
10	690113008	Self locking nut M16	16	16
11	690109203	Plast stopper 70x50x2	4	4

Edge equipment

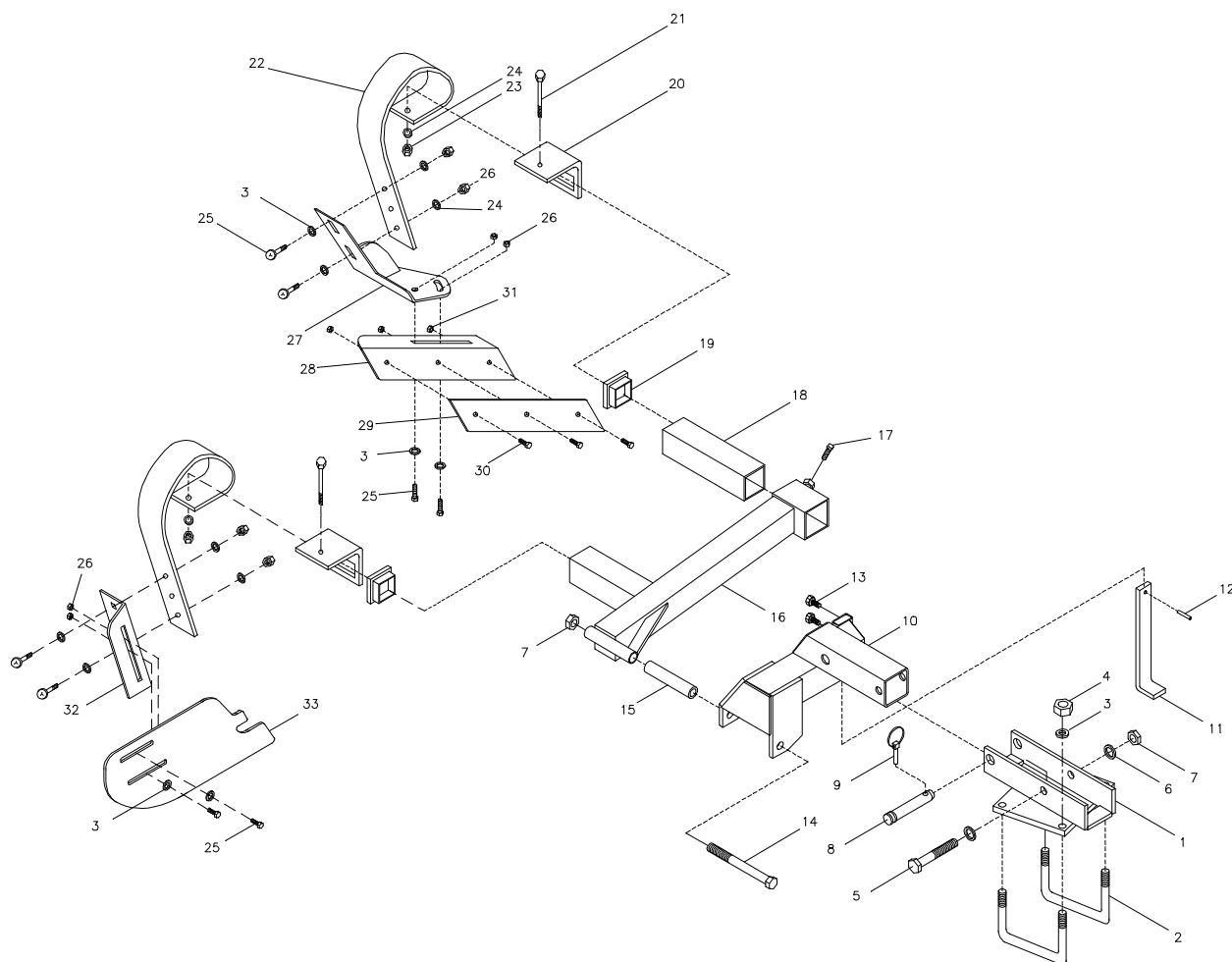

Pos.	Item no.	Designation	4,0 m	5,0 m
1	630933275	Bracket f/edge equipment	1	1
2	690110103	U-Bolt M16x100x150x100	2	2
3	690117013	Facet plate Ø16	12	12
4	690113008	Self-locking nut M16	4	4
5	690103171	Bolt M20x130	1	1
6	690117005	Facet plate Ø20	2	2
7	690113009	Self-locking nut M20	1	1
8	69525097J	Pin f/top link ø25 L=97	1	1
9	690134004	Ring pin ø10	1	1
10	630933277	Connecting link f/edge equipment (From machine no. 335893)	1	1
		Old model New model		

Pos.	Item no.	Designation	4,0 m	5,0 m
11	630933298	Depth adjusting device	1	1
12	690130161	Roll pin Ø8x40	1	1
13	690101079	Bolt M10x25	2	2
14	690103172	Bolt M20x200	1	1
15	630929130	Tube Ø30 L=148	1	1
16	630933285	Arm f/edge plough (From machine no. 335893)	Old model New model	1 1
	690103284	Bolt M16x100	Old model	1 1
	690115008	Washer Ø17 x 40 x 6mm	Old model	1 1
	690112005	Nut M16	Old. model	1 1
17	690103124	Bolt M16x 35	1	1
18	630933287	Bar f/edge plough	1	1
19	690109202	Plastic plug	4	4
20	633052200	Clamp for tine	2	2
21	690103088	Bolt M12x110	2	2
22	633052050	Tine (10x80)	2	2
23	690113013	Self-locking nut M12 (all-metal)	2	2
24	690117014	Facet plate Ø12	6	6
25	690101220	Bolt M12x45 (carrier bolt)	8	8
26	690113006	Self-locking nut M12	8	8
27	630949430	Bracket f/edge plough	1	1
28	630949440	Edge plough	1	1
29	630949445	Share f/edge plough	1	1
30	690101210	Bolt M10x30 (carrier bolt)	3	3
31	690113005	Self-locking nut M10	3	3
32	630949420	Bracket f/edge plate	1	1
33	630949410	Edge plate	Old model	1 1
33	630949412	Edge plate (From machine no. 335893)	New model	1 1

Edge equipment from machin number 341738

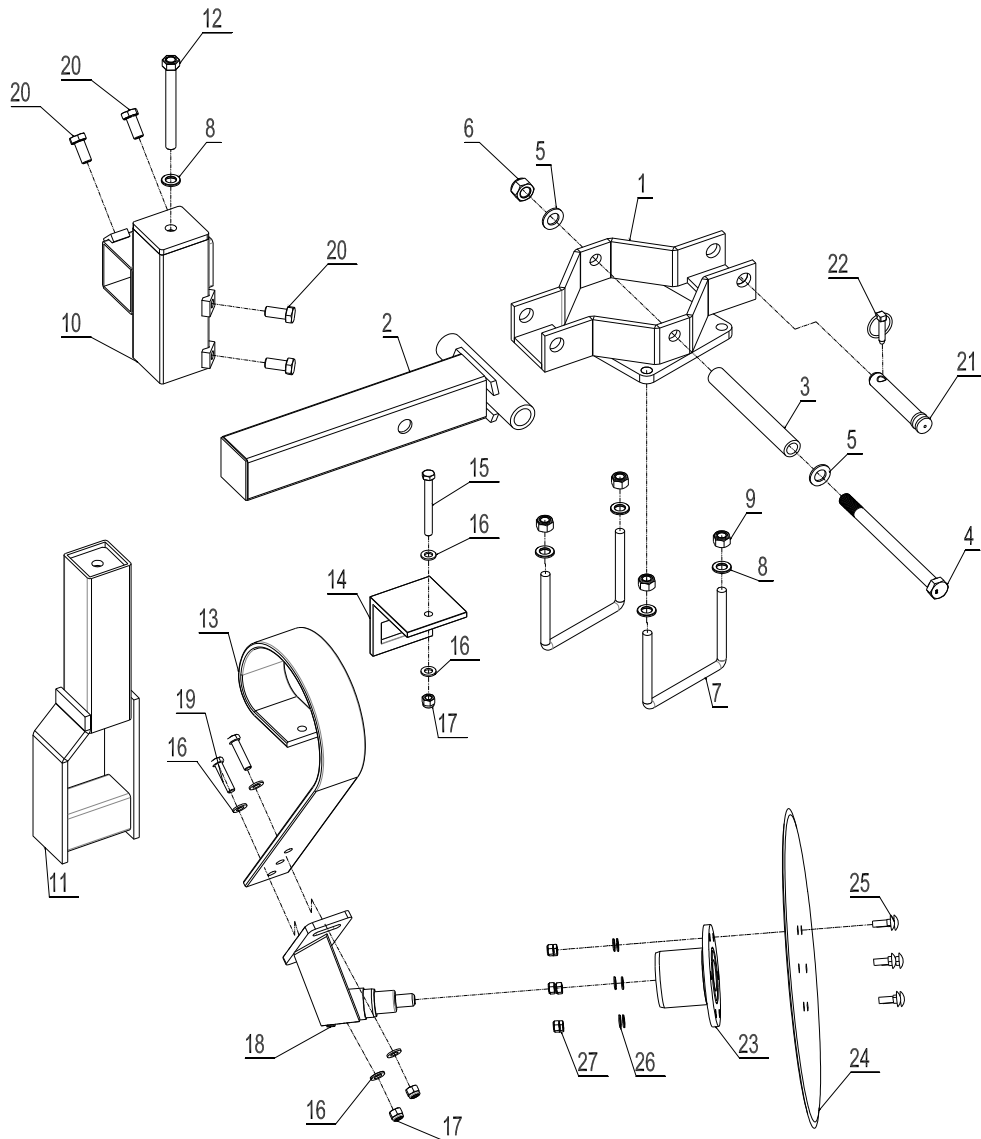

Pos.	Item no.	Designation	3,0 m	3,5 m	4,0 m
	630943094	Complete edge equipment			
1	630943088	Mounted holder	1	1	1
2	630943090	Mounted element	1	1	1
3	630943095	Tube 30x5 L= 233	1	1	1
4	690103285	Bolt M20x280 8.8	1	1	1
5	690117005	Facet plate Ø20	1	2	2
6	690113009	Self-locking nut M20	1	1	1
7	690110103	U-bolt M16x100x150x100	1	2	2
8	690117013	Facet plate Ø16	1	5	5
9	690113008	Self-locking nut M16	1	4	4

Pos.	Item no.	Designation	3,0 m	3,5 m	4,0 m
10	630943099	Mounted spindle cross	1	1	1
11	630943102	Mounted tine holder/spindle	1	1	1
12	630943109	Adjusting bolt	1	1	1
13	633052050	Springboard tine 80x10mm - long	1	1	1
14	633052200	Clamp for Spring-Board tine	1	1	1
15	690103098	Bolt M12x110 10.9	1	1	1
16	690117014	Facet plate Ø12	6	6	6
17	690113006	Self-locking nut M12	3	3	3
18	630943080	Mounted bracket	1	1	1
19	690103096	Bolt M12x50 8.8	2	2	2
20	690103117	Bolt M14x40 8.8 set-bolt	4	4	4
21	69525107J	Pin ø28 L=107	1	1	1
22	690134004	Ring pin Ø10	1	1	1
23	630949035	Hub	1	1	1
24	690153509	Disc, plain, ø508x4,0mm	1	1	1
25	690101210	Cariage bolt M10x30 8.8	6	6	6
26	690117012	Facet plate Ø10	6	6	6
27	690113005	Self-locking nut M10	6	6	6

Spare parts list - Extra equipment

Material damper guard

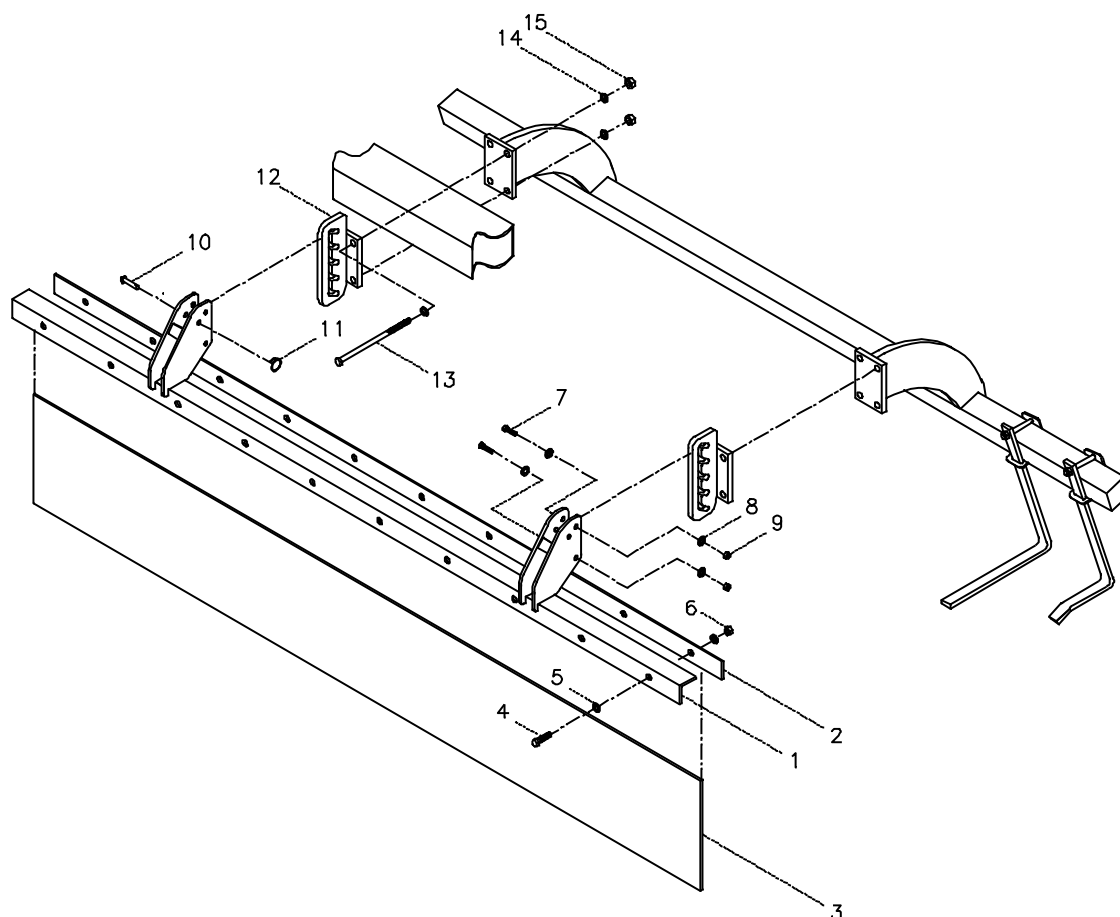

Pos.	Item no.	Designation	4,0 m	5,0 m
1	630928540	Bar f/material damper guard	2	0
1	630938583	Bar f/material damper guard (left) From machin no. 344861	1	
1	630938584	Bar f/material damper guard right) From machin no. 344861	1	
1	630938540	Bar f/material damper guard	0	2
1	630938580	Bar f/material damper guard right) From machin no. 344861		1
1	630938582	Bar f/material damper guard (left) From machin no. 344861		1
2	630928538	Clamping plate f/material damper guard	2	0
2	630938538	Clamping plate f/material damper guard	0	2

Pos.	Item no.	Designation	4,0 m	5,0 m
3	630928528	Rubber mat L= 1980	2	0
3	630938528	Rubber mat L= 2480	0	2
4	690103054	Bolt M8x40	16	20
5	690117004	Facet plate Ø8	32	40
6	690113004	Self-locking nut M8	16	20
7	690103096	Bolt M12x50	8	8
8	690117014	Facet plate ø12	16	16
9	690113006	Self-locking nut M12	8	8
10	69512040K	Pin Ø12,5 L=40	4	4
11	690134000	Locking ring 30 x Ø3	4	4
12	630938545	Suspension f/material damper guard	4	4
13	690103295	Bolt M16x260	16	16
14	690117013	Facet plate Ø16	32	32
15	690113008	Self-locking nut M16	16	16

Spring-Board (left) 4,0 – 5,0m

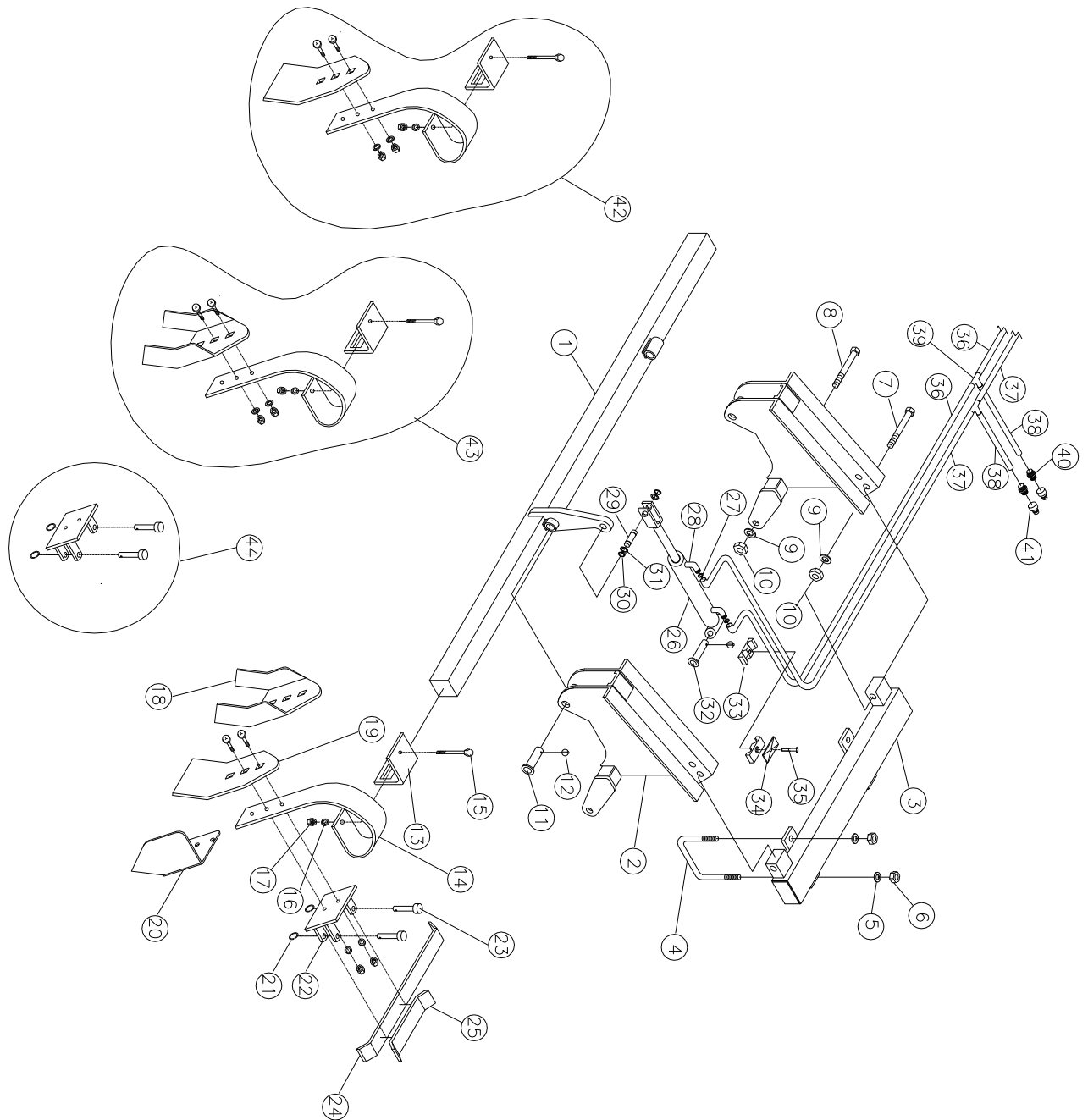

Pos	Item no.	Designation	4,0 m	5,0 m
1	633923000	Bar (left)	1	
1	633923001	Bar (right)	1	
1	635933001	Bar (left)		1
1	635933000	Bar (right)		1
2	633910020	Horn	4	4
2	633910030	Horn prepared for supporting wheel From machin no.: 344861	4	4
3	633921100	Mounting bar (right)	1	
3	633921101	Mounting bar (left)	1	
3	635931000	Mounting bar (right)		1
3	635931001	Mounting bar (left)		1
4	690110103	U-bolt M16x100x150x100	4	4
5	690117013	Facet plate Ø16	8	8
6	690113008	Self-locking nut M16	8	8
7	690103170	Bolt M20x110	4	4
8	690103178	Bolt M20x220	4	4
9	690117005	Facet plate Ø20	8	8
10	690113009	Self-locking nut M20	8	8
11	69525087F	Pin Ø25 L=87	4	4
12	690134001	Ring pin Ø4,5	6	6
13	633052200	Clamp for tine	16	20
14	633052050	Tine (10x80)	16	20
15	690103098	Bolt M12x110 10.9	16	20
16	690117014	Facet plate Ø12	16	20
17	690113006	Self-locking nut M12	16	20
18	633052150	Slicing plates point incl. bolts	16	20
19	633052100	Tine point (8x150) incl. bolts	16	20
20	633052250	Edge equipment (left)	1	1
20	633052255	Edge equipment (right)	1	1
21	690134000	Locking ring Ø30x3	32	40
22	633055500	Tine bracket f/transverse locking system	16	20
23	69512040K	Pin Ø12,5x40	32	40
24	633055710	Locking bar f/transverse locking system (long)	14	18
25	633055700	Locking bar f/transverse locking system (short)	4	4

Pos	Item no.	Designation	4,0 m	5,0 m
26	690200160	Cylinder 50/30x155	2	2
26a	690200046	Gasket set 50/30		
27	690207901	Restrictor 1 mm	4	4
28	690203006	Fitting, 90angle, 10x3/8" BSP	4	4
29	69520046D	Pin Ø20 L=46	2	2
30	691372020	Seeger circlip ring Ø20	4	4
31	690115010	Washer Ø20/Ø28 x 1mm	4	4
32	69520087F	Pin Ø20 L=87	2	2
33	690210210	Tube-support double Ø14/Ø14	4	4
34	690210211	Top plate f/double tube-support	2	2
35	690103054	Bolt M8x40	2	2
36	690201053	Hydraulic hose 1260 mm ¼" st/st	2	2
37	690201018	Hydraulic hose 1460 mm ¼" st/st	2	2
38	690201029	Hydraulic hose 4300 mm ¼" st/st	2	2
39	690203015	Fitting, T10	2	2
40	690203003	Fitting, straight 10-1/2" BSP	2	2
41	690203001	Quick coupling, male E402 ½"	2	2
42	633052000	Tine w/flat tine point (complete)		
43	633052025	Tine w/slicing plates point (complete)		
44	633055510	Tine bracket f/transverse locking system (complete)		

El. depth stop f/disc

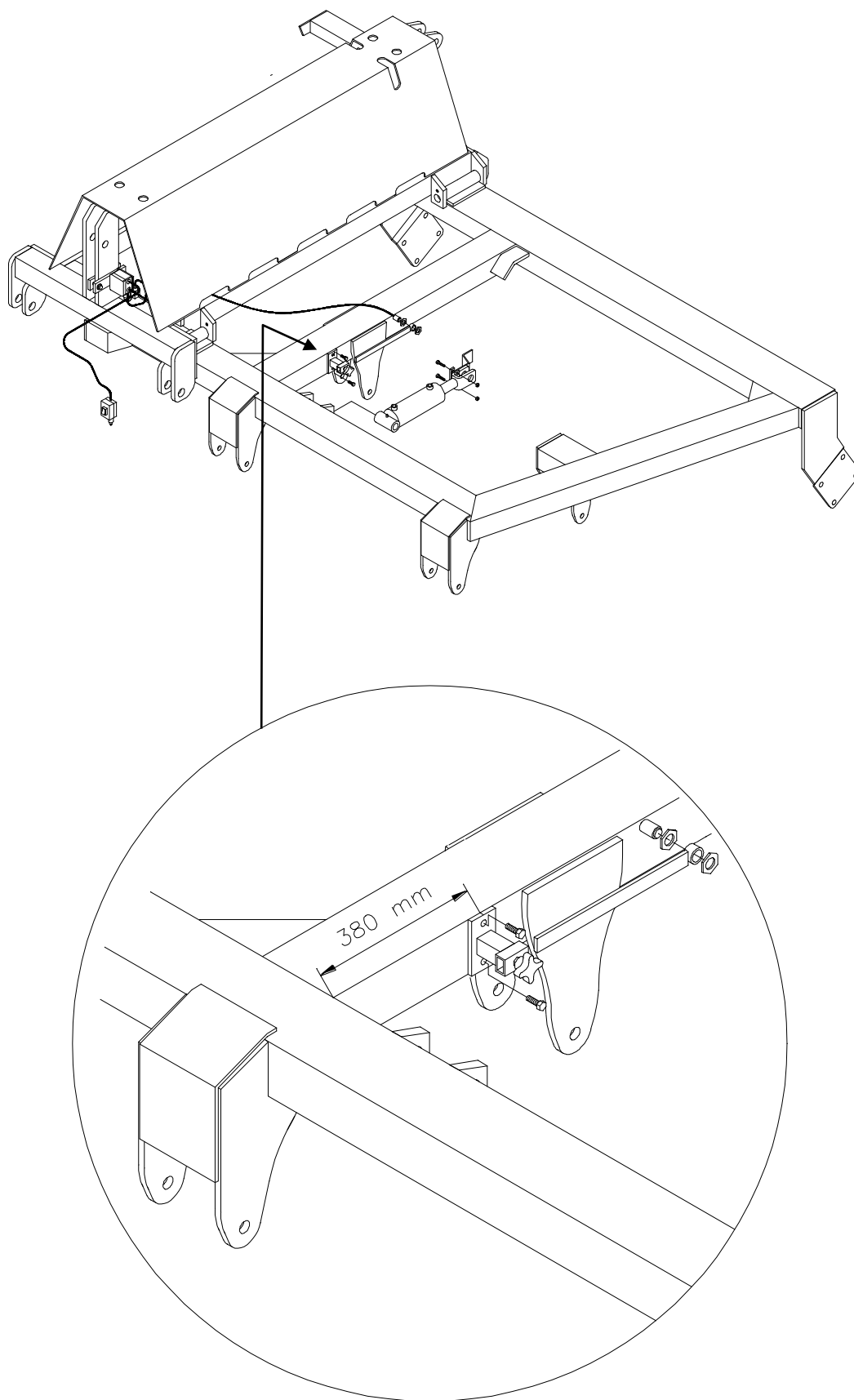

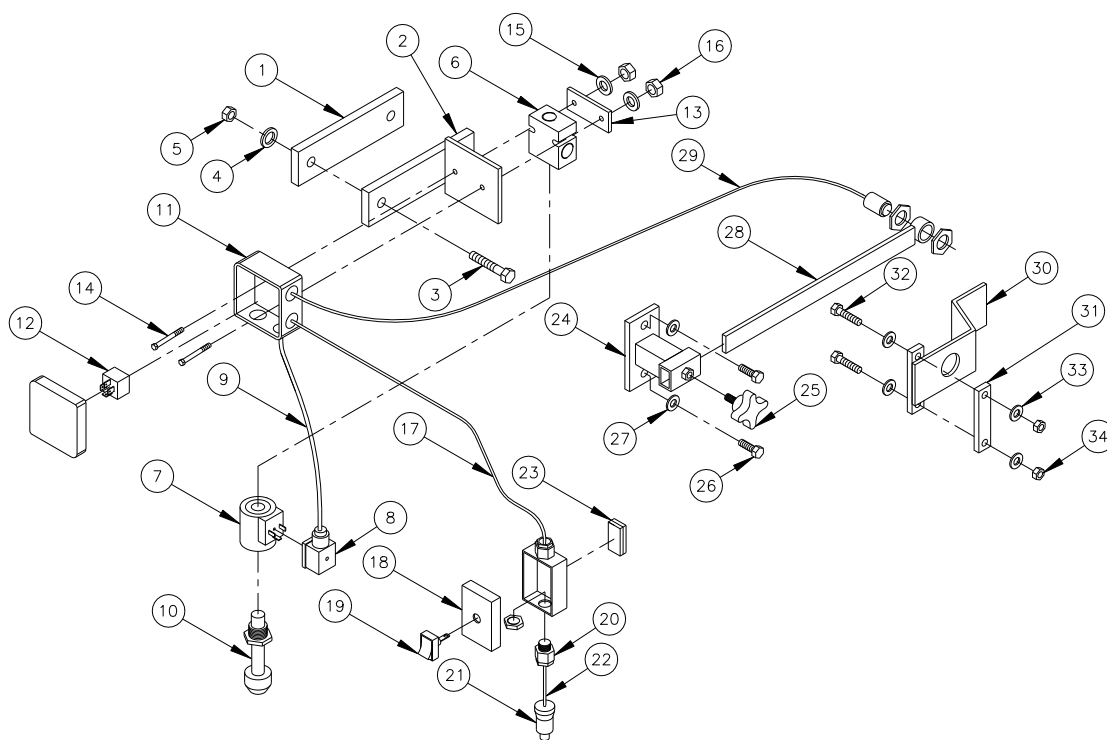

	Item no.	Designation	4,0 m	5,0 m
1	630932034	Clamping plate f/el. depth stop	1	1
2	630932035	Bracket f/connection box on el. depth stop	1	1
3	690103095	Bolt M12x60	2	2
4	690117014	Facet plate Ø12	2	2
5	690113006	Self-locking nut M12	2	2
6	690209455	Valve block 4B 10/2 1/2"	1	1
7	690209465	Magnet coil 12VDC 20W	1	1
8	690209030	Plug f/solenoid valve DIN 43650	1	1
9	690209440	Cable 2x0,75 mm ² L = 0,32m	1	1
10	690209460	Valve 10 NO	1	1
11	690209490	Connecting box 80x80x50	1	1
12	690209450	Relay 12V/30A	1	1
13	630941061	Clamping plate f/valve block	1	1
14	690103042	Bolt M6x60	2	2

	Item no.	Designation	4,0 m	5,0 m
15	690117003	Facet plate Ø6	2	2
16	690113003	Self-locking nut M6	2	2
17	690209440	Cable 2x0,75 mm ² L = 4,5m	1	1
18	690209486	Connecting box 72x50x41	1	1
19	690209480	Switch 0-1 (red) Ø12 hole mounting	1	1
20	690209475	Connector PG11 w/nut	2	2
21	690209470	Stik 2 pol +/- 12V	1	1
22	690209440	Cable 2x0,75 mm ² L = 1,0m	1	1
23	690210720	Velcro band L=65 mm	1	1
24	630949133	Bracket f/ scale/inductive sensor	1	1
25	690111080	Thumbscrew M8x20	1	1
26	690103049	Bolt M8x25	2	2
27	690117004	Facet plate Ø8	2	2
28	690209435	Scale f/ inductive sensor on el. depth stop	1	1
29	690209445	Inductive sensor with 1.8m cable	1	1
30	630939131	Sensor activator f/ inductive sensor	1	1
31	630939133	Clamping plate f/ sensor activator	1	1
32	690103057	Bolt M8x50	2	2
33	690117004	Facet plate Ø8	4	4
34	690113004	Self-locking nut M8	2	2

Lights

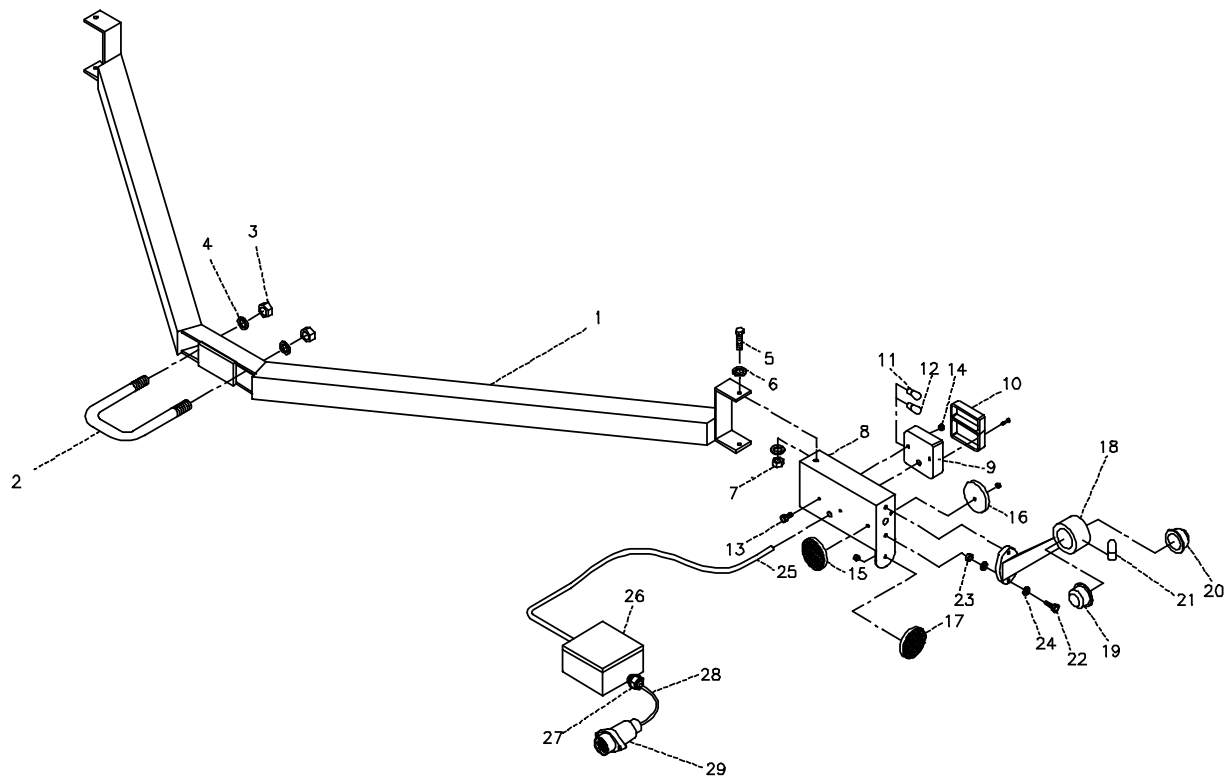

Pos.	Item no.	Designation	4,0 m	5,0 m
1	630930100	Light bar	1	1
2	690110101	U-bolt M16x100x100x100	1	1
3	690113008	Self-locking nut M16	2	2
4	690117013	Facet plate Ø16	2	2
5	690103025	Bolt M6x20	4	4
6	690117003	Facet plate Ø6	8	8
7	690113003	Self-locking nut M6	4	4
8	690160010	Light box (left)	1	1
8	690160011	Light box (right)	1	1
9	690160030	Rear light (complete)	2	2
10	690160031	Glass f/rear light	2	2
11	690160032	Bulb f/flasher 12V 1x21W – BA15s	2	2
12	690160033	Bulb f/rear- and stoplight 12V 1x21/5W – BAY 15d	2	2
13	690103014	Bolt M5x20	4	4
14	690113003	Self-locking nut M5	4	4

Pos.	Item no.	Designation	4,0 m	5,0 m
15	690160041	Reflex (white) w/screwed pin and nut	2	2
16	690160040	Reflex (red) w/holes	2	2
17	690160042	Reflex (yellow) w/screwed pin and nut	2	2
18	690160060	Marking lights (left + right)	2	2
19	690160065	Glass f/marketing lights (white)	2	2
20	690160066	Glass f/marketing lights (red)	2	2
21	690160067	Bulb f/marketing lights 12V 10W – BA 15 s	2	2
22	690210100	Screw M5x16	4	4
23	690113002	Self-locking nut M5	4	4
24	690117002	Facet plate Ø5	8	8
25	690160080	Cable 5 x 1 mm ² L = 2,0 m	2	2
26	690209492	Connecting box 105x105x60	1	1
27	690209475	Male connector PG11 w/nut	3	3
28	690160080	Cable 5 x 1 mm ² L = 6,0 m	1	1
29	690160070	Plug 7-poles DIN 72 577 – ISO 1724	1	1

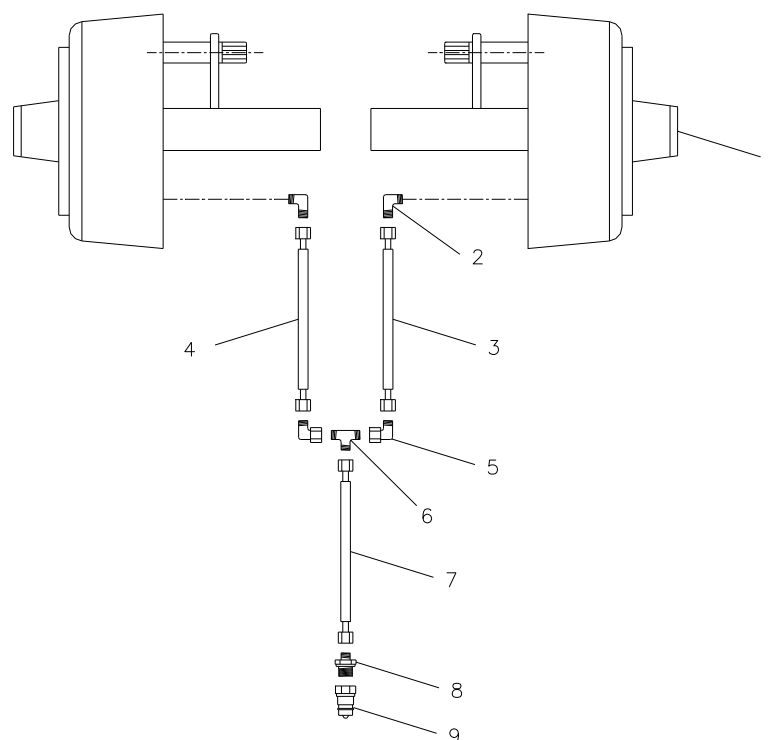
Hydraulic brakes

Pos.	Item no.	Designation	4,0 m	5,0 m
1		See pos. 12, page 20	2	0
1		See pos. 12, page 20	0	2
2	690203106	Fitting, 90angle 12-3/8" BSP	2	2
3		Hydraulic hose 1625 mm 1/4" st/st	1	1
4		Hydraulic hose 1625 mm 1/4" st/st	1	1
5	690203016	Fitting, 90angle 10mm	2	2
6	690203015	Fitting, T10	1	1
7		Hydraulic hose 6000mm 1/4" st/st	1	1
8	690203003	Fitting, straight 10-1/2" BSP	2	2
9	690203001	Quick coupling, male E402 1/2"	2	2

Air brakes

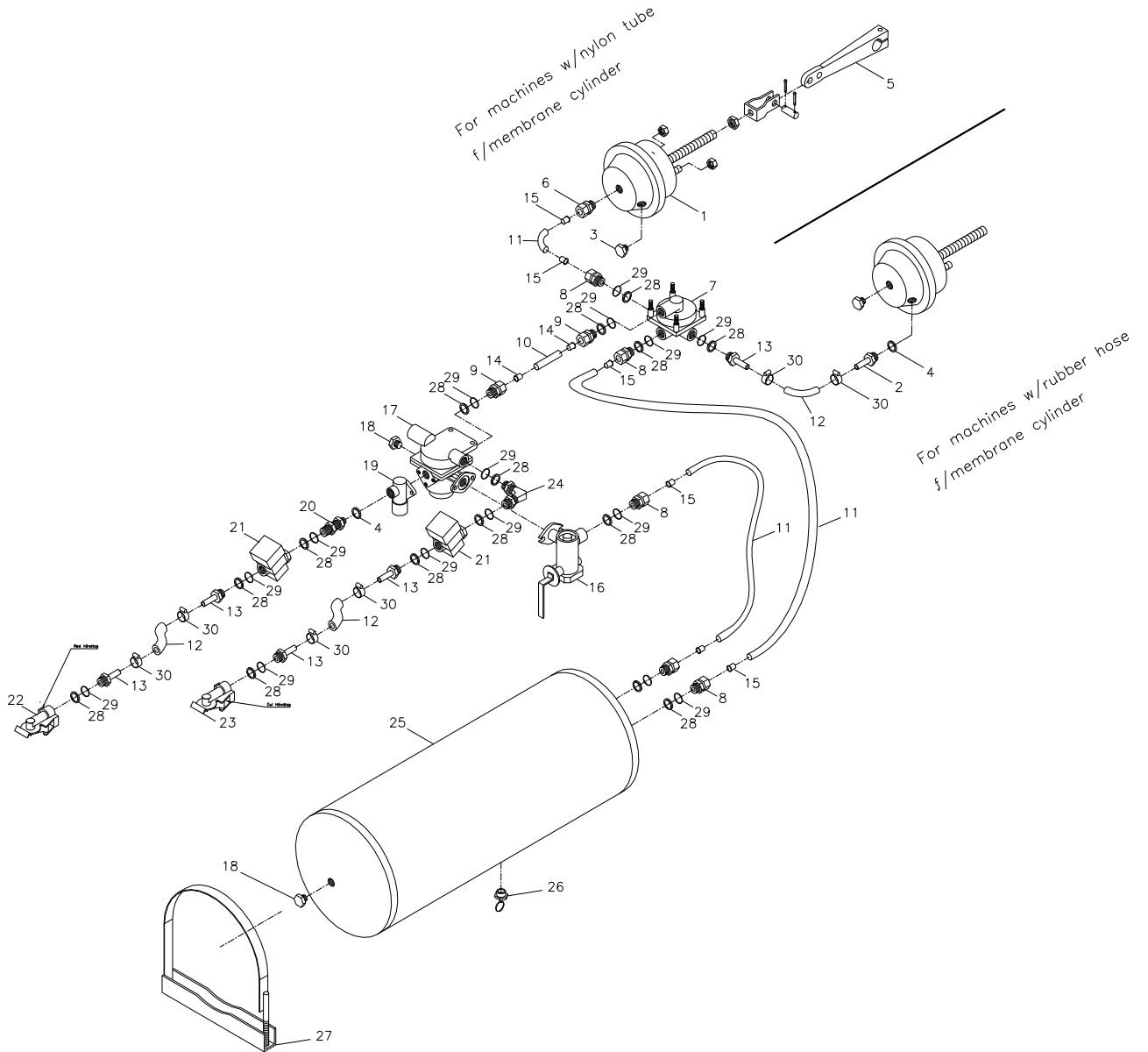

Pos.	Item no.	Designation	w/nylon tube f/ membrane cyl.	w/rubber hose f/membrane cyl.
1	690190001	Membrane cylinder 16"	2	2
2	690190070	Hose fitting M16x1.5 w/ Ø12	0	2
3	690190005	Test fitting, straight M16x1.5	2	2
4	690208102	Bonded seal PP 45-12	1	3
5	690190010	Mounting set, short U-bracket	2	2
6	690202930	Fitting, straight M16x1.5, Ø15 hose	2	0
7	690190015	Relay valve M22x1.5	1	1
8	690202941	Fitting, straight M22x1.5, Ø15 hose	6	4
9	690202940	Fitting, straight M22x1.5, Ø10 hose	2	2
10	690190080	Nylon tube Ø10x1mm	1	1
11	690190085	Nylon tube Ø15x1.5mm	4	2
12	690190105	Hose Ø14.5x5mm	2	4
13	690190073	Hose fitting M22x1.5, w/Ø12	4	6
14	690190090	Support bushing f/tube Ø10x1.5mm	2	2
15	690190095	Support bushing f/tube Ø15x1.5mm	8	4
16	690190020	Brake power regulator M22x1.5	1	1
17	690190025	Trailer air brake valve M22x1.5	1	1
18	690190026	Plug	2	2
19	690190035	Relief valve	1	1
20	690203420	Fitting, straight M16x1.5+M22x1.5	1	1
21	690190040	Filter M22x1.5	2	2
22	690190045	Hose coupling M22x1.5 (red)	1	1
23	690190046	Hose coupling M22x1.5 (yellow)	1	1
24	690190030	V-fitting M22x1.5	1	1
25	690190050	Air receiver 40 l	1	1
26	690190051	Drainage valve	1	1
27	690190052	Suspension for air receiver	2	2
28	690190060	Pressure ring M22x1.5	15	15
29	690190065	O-ring M22x1.5	15	15
30	690109305	Hose clamp 15-24 mm	4	8

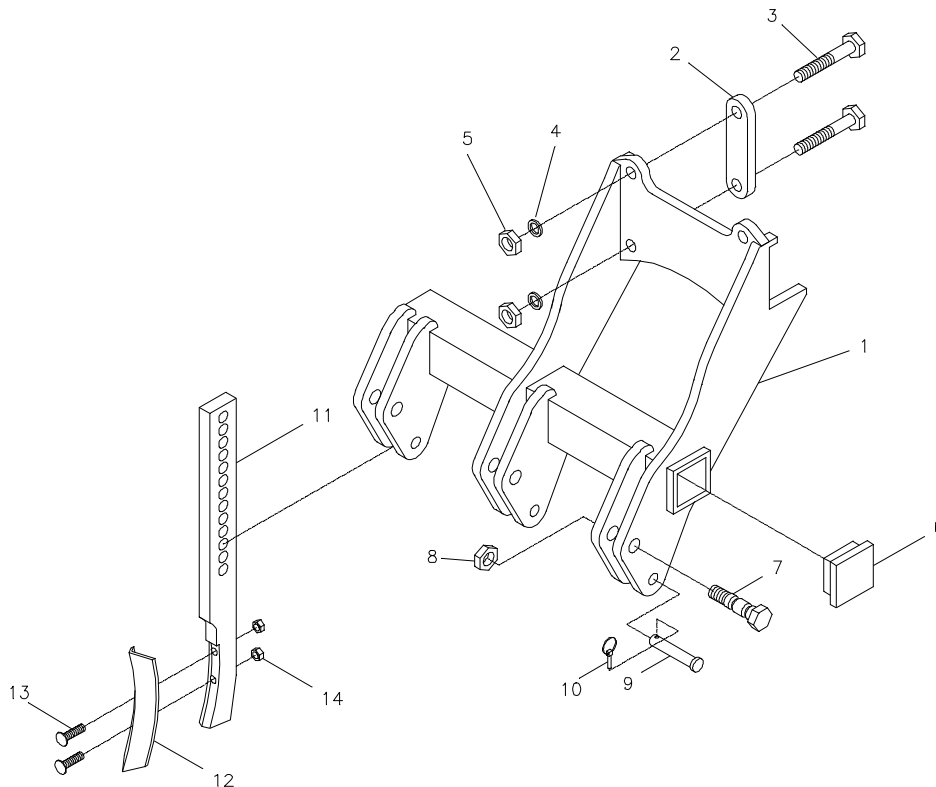
Tine eradicator set
Can only be mounted on trailed models

Pos.	Item no.	Designation	4,0 m	5,0 m
1	630919015	Bracket for tine support (right)	1	1
1	630919005	Bracket for tine support (left)	1	1
2	630919016	Mounting plate	4	4
3	690103195	Bolt M16x200	8	8
4	690117013	Facet plate Ø16	8	8
5	690113008	Self-locking nut M16	8	8
6	690109200	Plastic plug 60x60	4	4
7	690152045	Spring bolt M20x85	6	6
8	690113009	Self-locking nut M20	6	6
9	69516074J	Pin Ø16 L=74	6	6
10	690134001	Ring pin Ø4.5	6	6
11	690152042	Tine eradicator	6	6
12	690152044	Tine eradicator point	6	6
13	690101625	Bolt M10x70 (plough bolt)	12	12
14	690113005	Self-locking nut M10	12	12

Supporting wheel (model for Spring-Board)
from machin no.: 344861

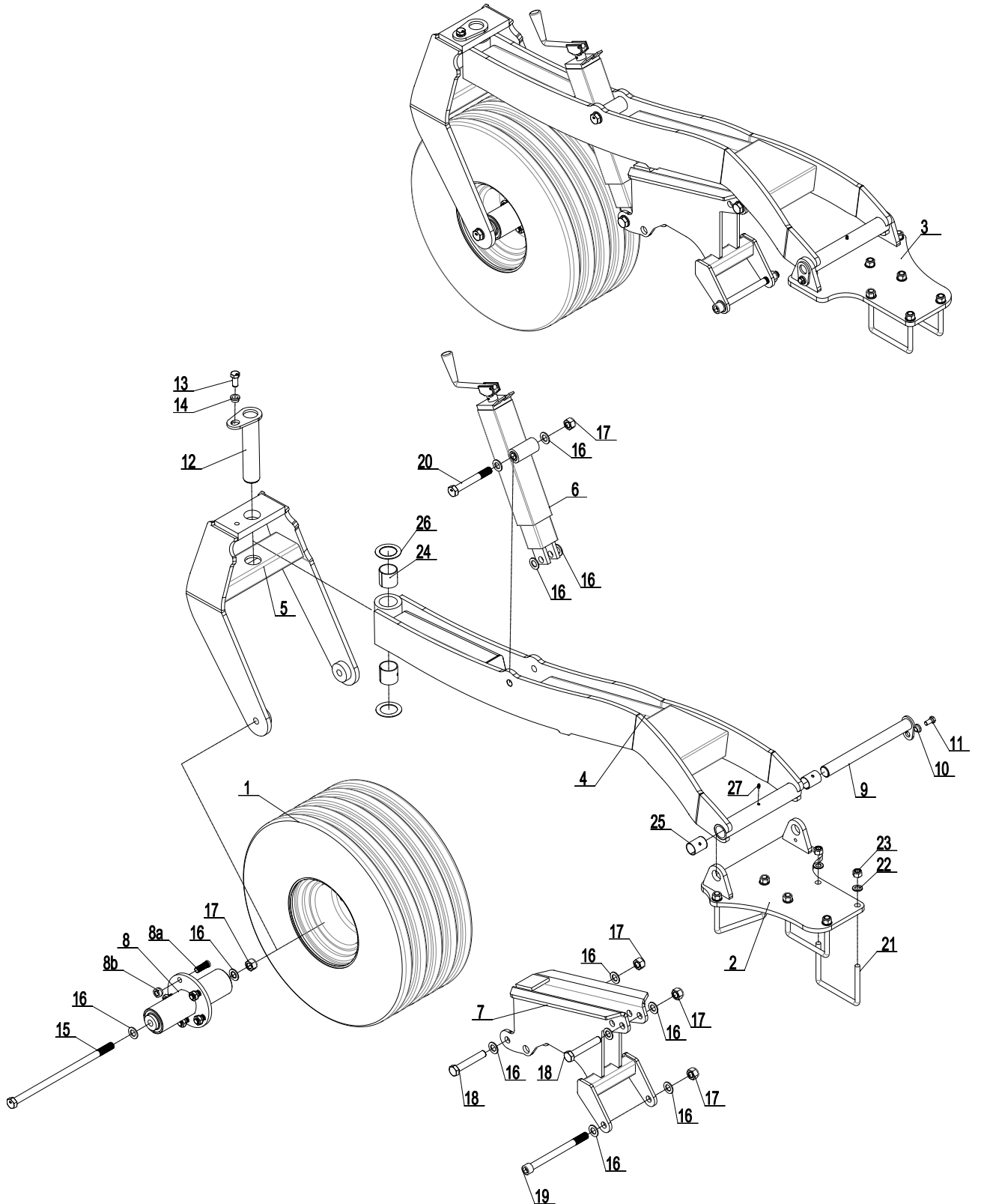

Pos.	Item no.	Designation	4.0m	5.0m
1	0395650	Wheel 300/65x12, Complete	2	2
2	630910723	Rear bracket, left supporting wheel	1	1
3	630910752	Rear bracket, right supporting wheel	1	1
4	630910719	Wheel assembly f/Spring-Board	2	2
5	630910729	Wheel suspension	2	2
6	675101001	Complete spindle	2	2
7	633910030	Spring-Board horn f/ supporting wheel	2	2
8	630910750	Hub 5-M16/94-140 - Hub lenght 320mm - M20	2	2
8a	0395271	Hub bolt M16 x 1,5 x 50	10	10
8b	0395291	Hub nut M16 x 1,5 R19	10	10
9	69435355G	Pin Ø35 L=355	2	2
10	630532600	Lock bush for pin head f/M12 bolt	2	2
11	690101101	Bolt M12x25 8.8	2	2
12	69450230G	Pin Ø50 L=230	2	2
13	690103124	Bolt M16x35 8.8	2	2
14	630532700	Lock bush for pin head f/M16 bolt	2	2
15	690103286	Bolt M20x420 8.8	2	2
16	690117005	Facet plate Ø20	24	24
17	690113009	Self-locking nut M20	10	10
18	690103159	Bolt M20x120 8.8	4	4
19	690103002	Hexagon bolt M20x240 12.9	2	2
20	690103163	Bolt M20x150 8.8	2	2
21	690110103	U-bolt M16x100x150x100	6	6
22	690117013	Facet disc Ø16	12	12
23	690113008	Self-locking nut M16	12	12
24	690140710	Bearing bush Ø50/55 L=50	4	4
25	690140716	Bearing bush Ø35/39 L=50	4	4
26	690140712	Sliding washer Ø52/Ø78x2	4	4
27	690136001	Lubrication nipple M6,	4	4

Supporting wheel (model without Spring-Board)

from machin no.: 344861

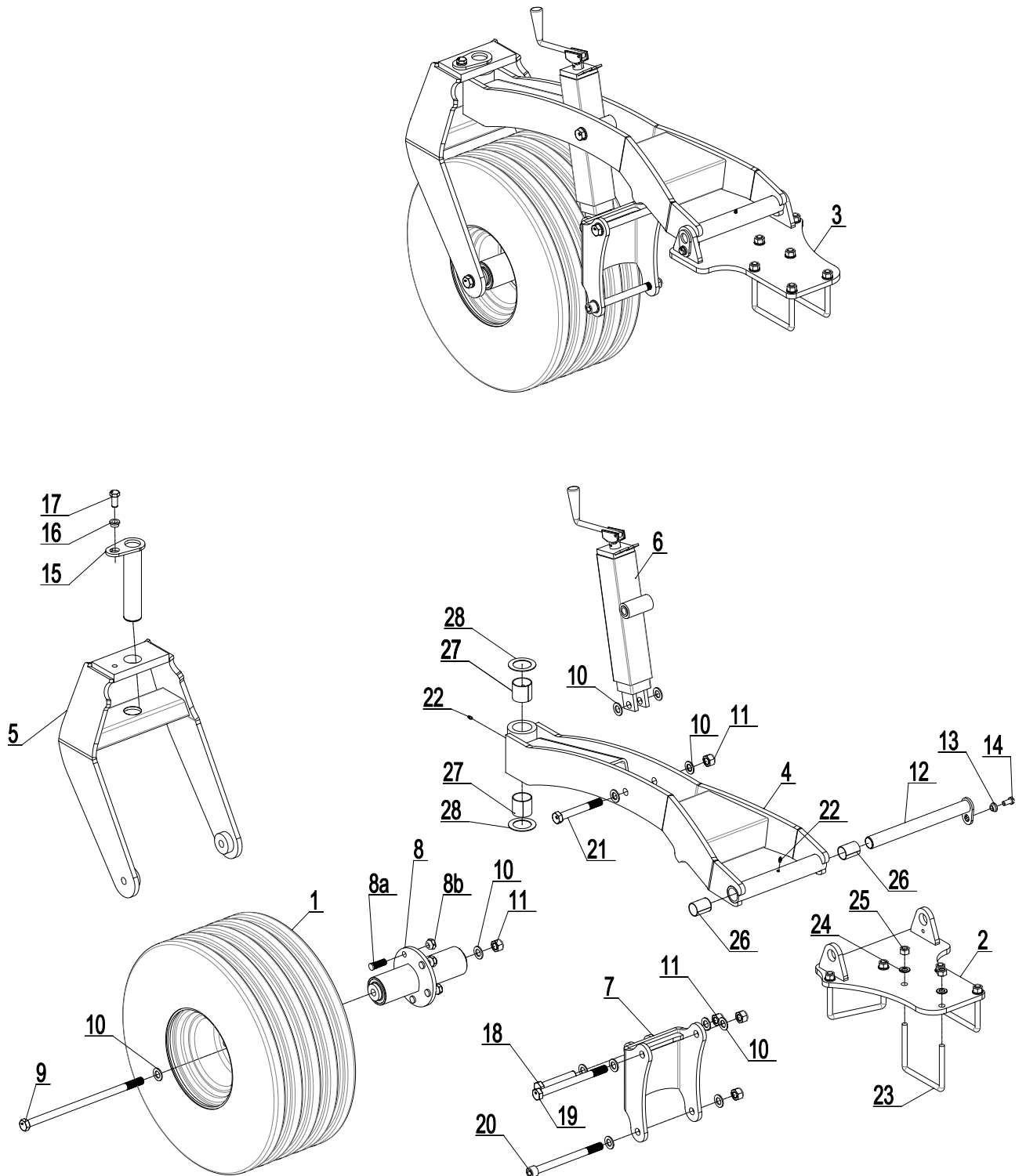

Pos.	Item no.	Designation	4.0m	5.0m
1	0395650	Wheel 300/65x12, Complete	2	2
2	630910723	Rear bracket, left supporting wheel	1	1
3	630910752	Rear bracket, right supporting wheel	1	1
4	630910732	Wheel assembly	2	2
5	630910729	Wheel suspension	2	2
6	675101001	Complete spindle	2	2
7	630910745	Suspension for spindle	2	2
8	630910750	Hub 5-M16/94-140 - Hub length 320mm - M20	2	2
8a	0395271	Hub bolt M16 x 1,5 x 50	10	10
8b	0395291	Hub nut M16 x 1,5 R19	10	10
9	690103286	Bolt M20x420 8.8	2	2
10	690117005	Facet plate Ø20	24	24
11	690113009	Self-locking nut M20	10	10
12	69435355G	Pin Ø35 L=355	2	2
13	630532600	Lock bush for pin head f/M12 bolt	2	2
14	690101101	Bolt M12x25 8.8	2	2
15	69450230G	Pin Ø50 L=230	2	2
16	630532700	Lock bush for pin head f/M16 bolt	2	2
17	690103124	Bolt M16x35 8.8	2	2
18	690103159	Bolt M20x120 8.8	2	2
19	690103183	Bolt M20x240 8.8	2	2
20	690103002	Hexagon bolt M20x240 12.9	2	2
21	690103163	Bolt M20x150 8.8	2	2
22	690136001	Lubrication nipple M6,	4	4
23	690110103	U-bolt M16x100x150x100	6	6
24	690117013	Facet disc Ø16	12	12
25	690113008	Self-locking nut M16	12	12
26	690140716	Bearing bush Ø35/39 L=50	4	4
27	690140710	Bearing bush Ø50/55 L=50	4	4
28	690140712	Sliding washer Ø52/Ø78x2	4	4

Spare parts list - Hydraulics

Hydraulics between drawbar and wheel frame

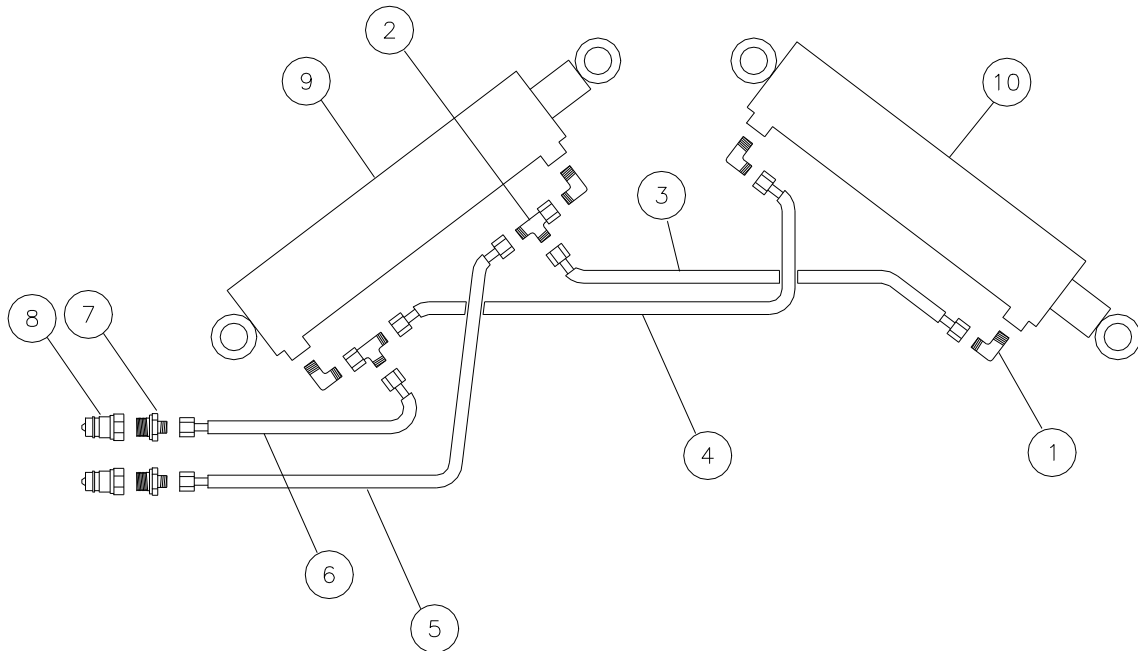

Pos.	Item no.	Designation	Number
1	0446200	Angle $\varnothing 12$ inner tube/ 3/8" BSP	4
2	690203017	Fitting T12L, premounted w/O-ring	2
3	690201237	Hydraulichose 2800mm 3/8" st/st	1
4	690201236	Hydraulichose 3000mm 3/8" st/st	1
5	690201232	Hydraulichose 3520mm 3/8" st/st	1
6	690201231	Hydraulikhose 3320mm 3/8" st/st	1
7	690203103	Fitting, straight, 12- 1/2" BSP	2
8	690203001	Quick coupling, male E402 1/2"	2
9		See pos. 12, page 18	1
10		See pos. 5, page 21	1

Hydraulics for folding up of side sections

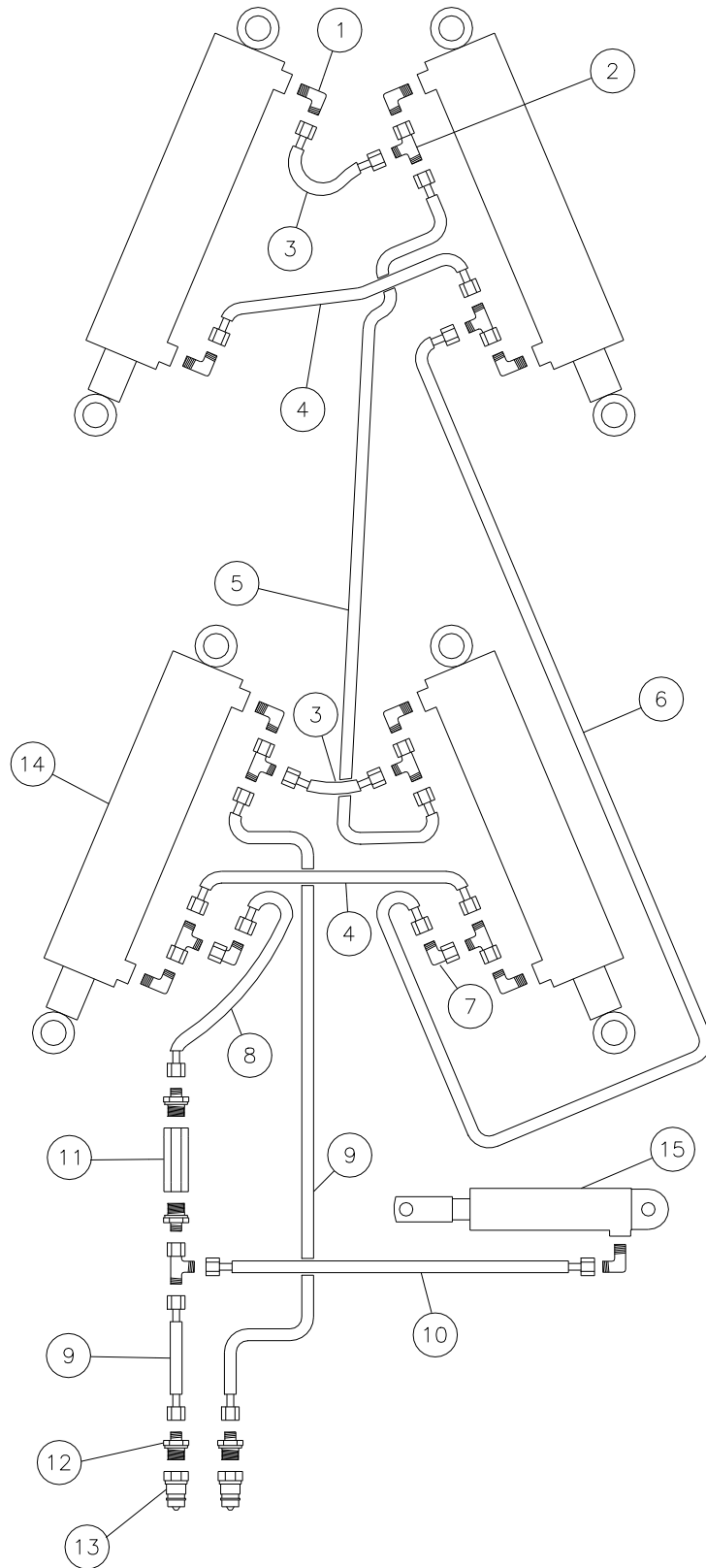

Pos.	Item no.	Designation	Number
1	690203006	Fitting, 90angle 10-3/8”BSP	8
2	690203120	Fitting, T10L, premounted w/O-ring	6
3	690201009	Hydraulic hose 355mm 1/4” st/st	2
4	690201069	Hydraulic hose 450mm 1/4” st/st	2
5	690201036	Hydraulic hose 1590mm ¼” st/st	1
6	690201016	Hydraulic hose 1830mm ¼” st/st	1
7	690203016	Fitting 90angle10 mm	2
8	690201042	Hydraulic hose 500mm 1/4” st/st	1
9	690201020	Hydraulic hose 1625mm ¼” st/st (Mounted models)	2
9	690201038	Hydraulic hose 4000mm ¼” st/st (Trailed models)	2
10	690201020	Hydraulic hose 1625mm ¼” st/st	1
11	690207215	Sequential valve, adjustable	1
12	690203003	Fitting, straight 10-1/2”BSP	4
13	690203001	Quick coupling male E402 ½”	2
14		See pos. 2, page 19	4
15		See pos. 17, page 20	1

Hydraulics for adjustment of disc

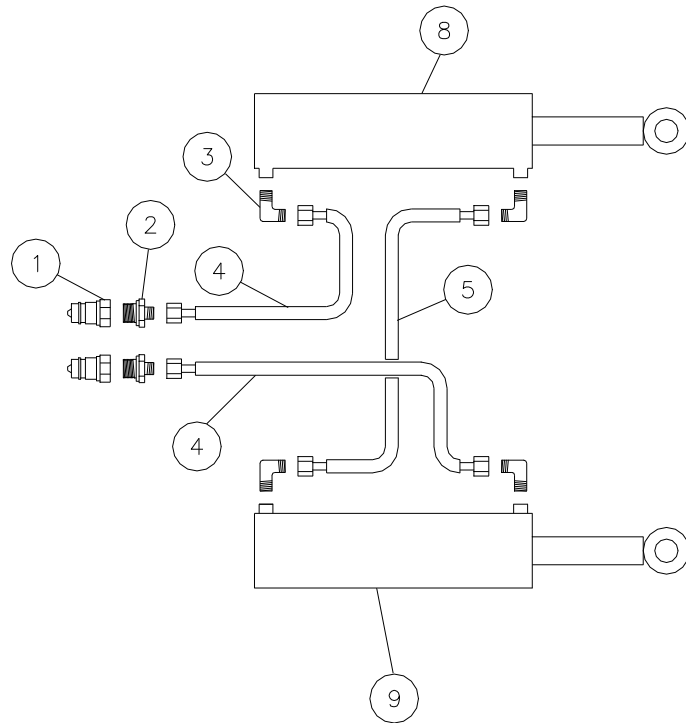

Without el. depth stop

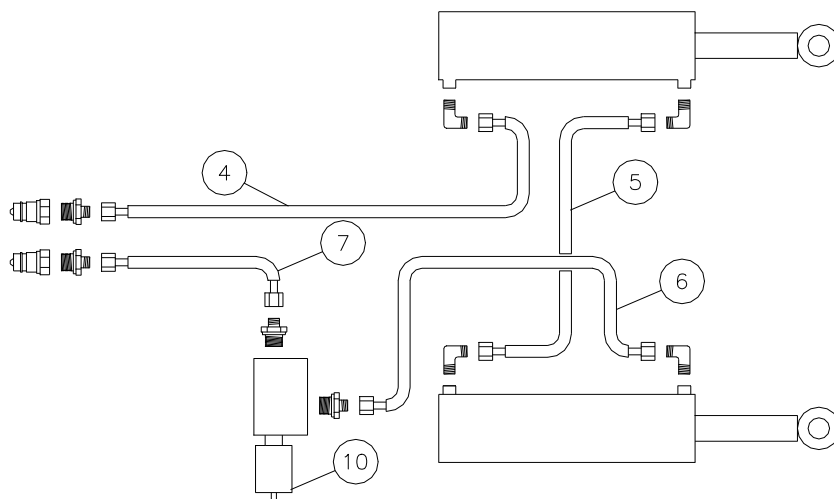

With el. depth stop

Pos.	Item no.	Designation	Without el. depth stop	With el. depth stop
1	690203001	Quick coupling male E402 1/2"	2	2
2	690203003	Fitting, straight, 10-1/2"BSP	2	4
3	690203006	Fitting, 90angle, 10-3/8"BSP	4	4
4	690201025	Hydraulic hose 5640mm 1/4" st/st (Trailed models)	2	1
4	690201022	Hydraulic hose 3140mm 1/4" st/st (Mounted models)	2	1
5	690201033	Hydraulic hose 2500mm 1/4" st/st (Mounted and trailed model)	1	1
6	690201020	Hydraulic hose 1625mm 1/4" st/st (Mounted and trailed model)	0	1
7	690201029	Hydraulic hose 4300mm 1/4" st/st (Trailed models)	0	1
7	690201016	Hydraulic hose 1830mm 1/4" st/st (Mounted models)	0	1
8		See pos. 5, page 23	1	1
9		See pos. 5, page 23	1	1
10	690209453	Depth stop valve, electric (complete)	0	1

Diagrams

El. depth stop

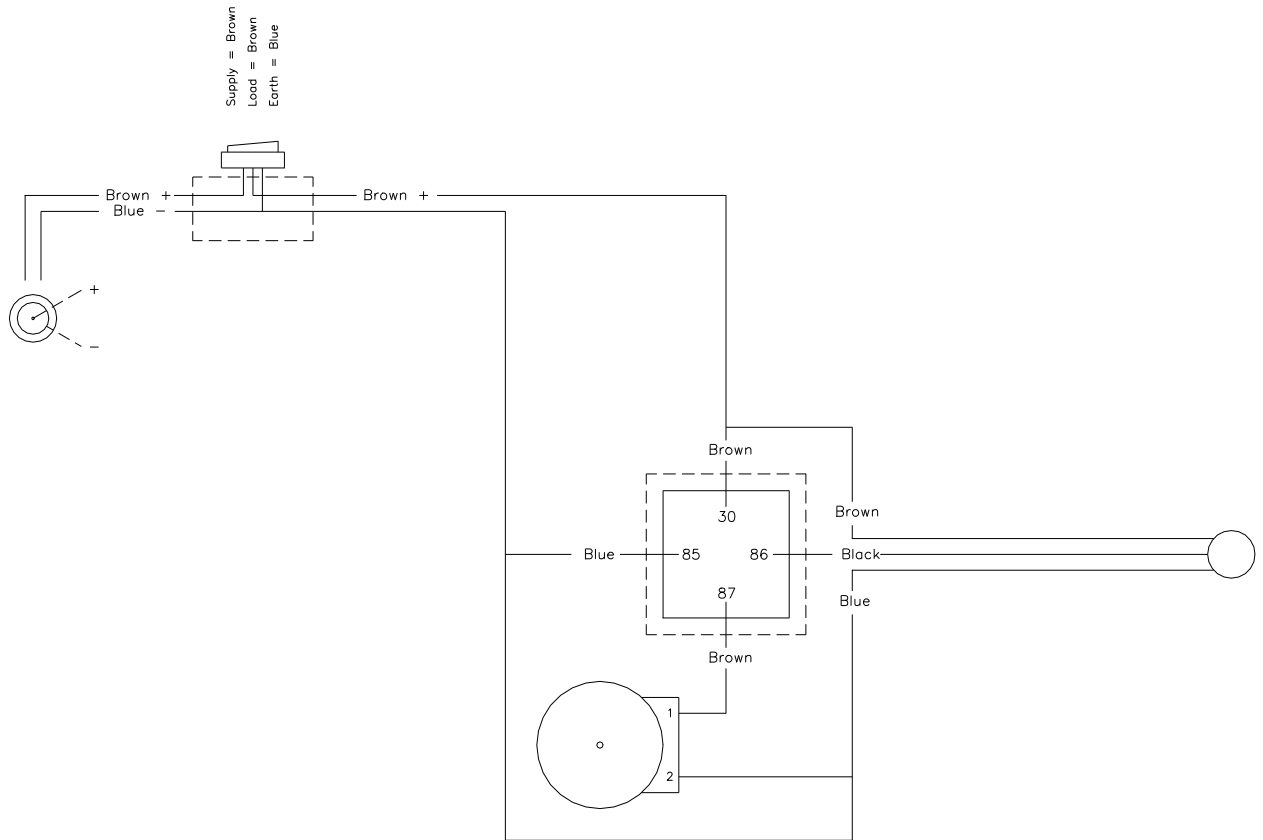

Lights

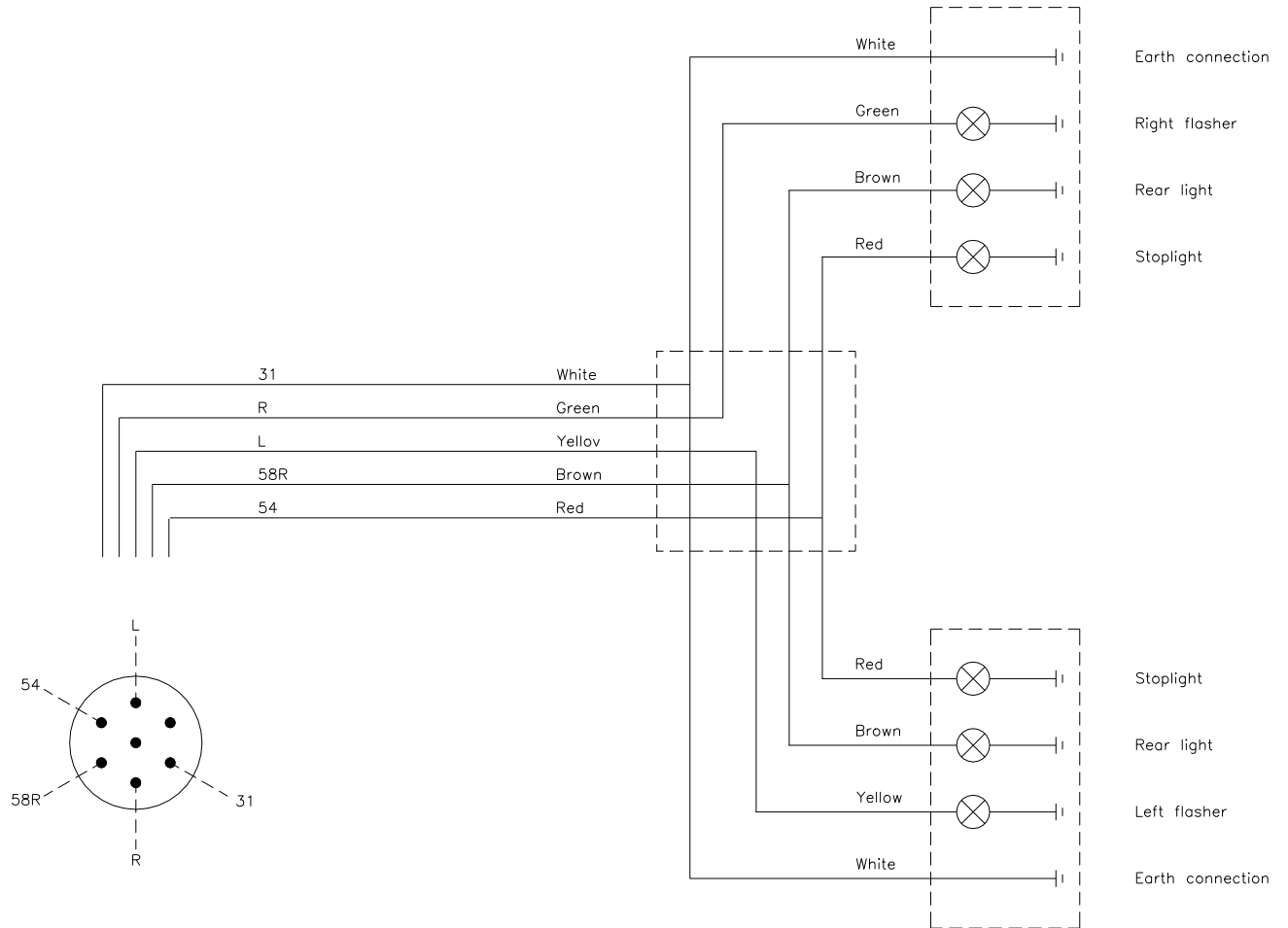

Hydraulics

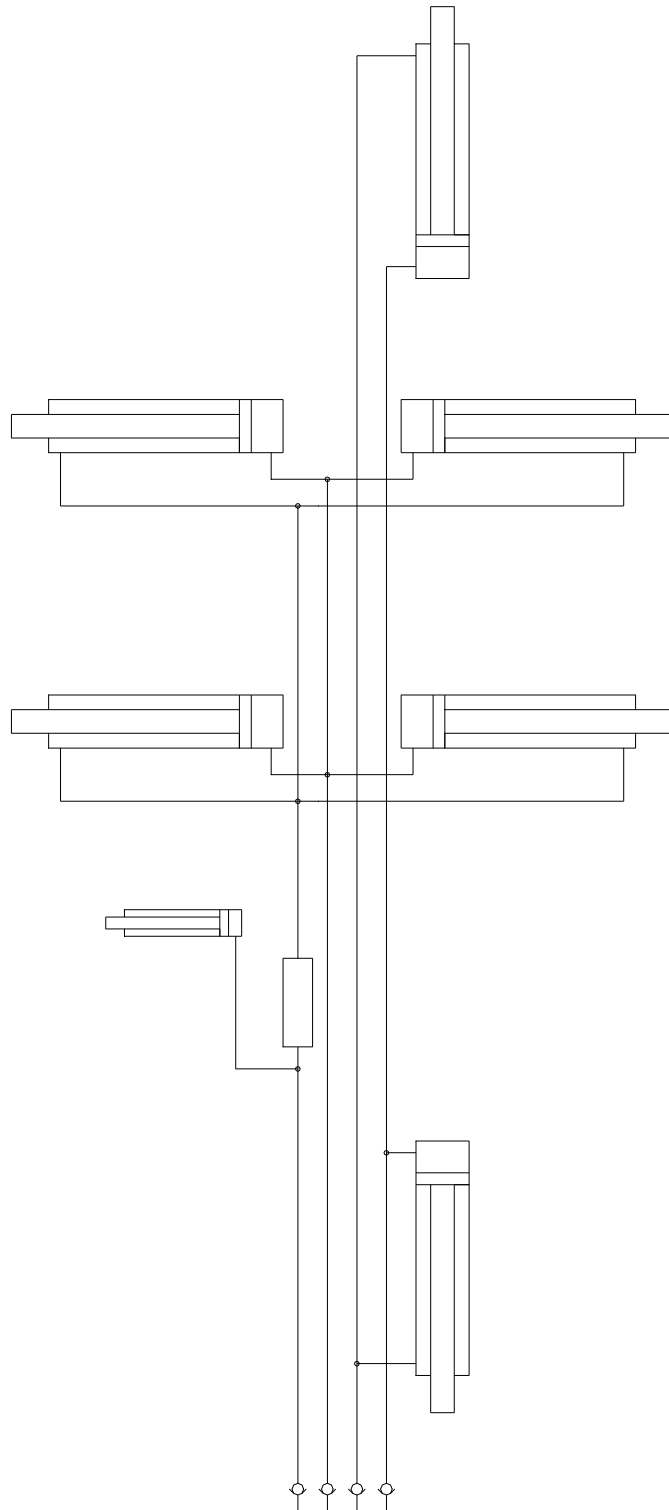

Hydraulics f/depth stop

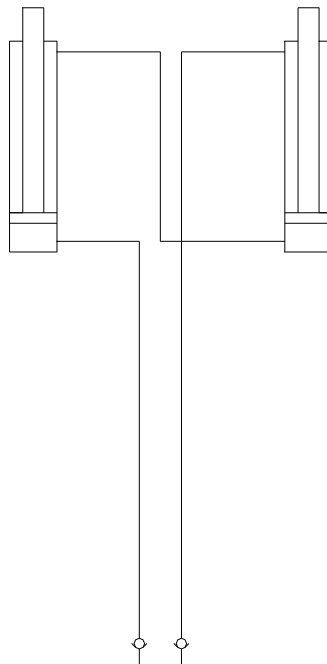

Hydraulics f/el. depth stop

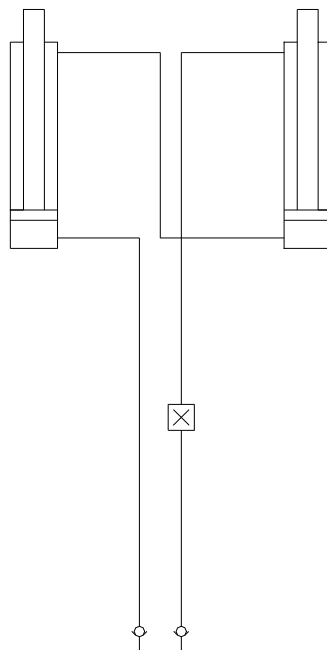

NOTES:

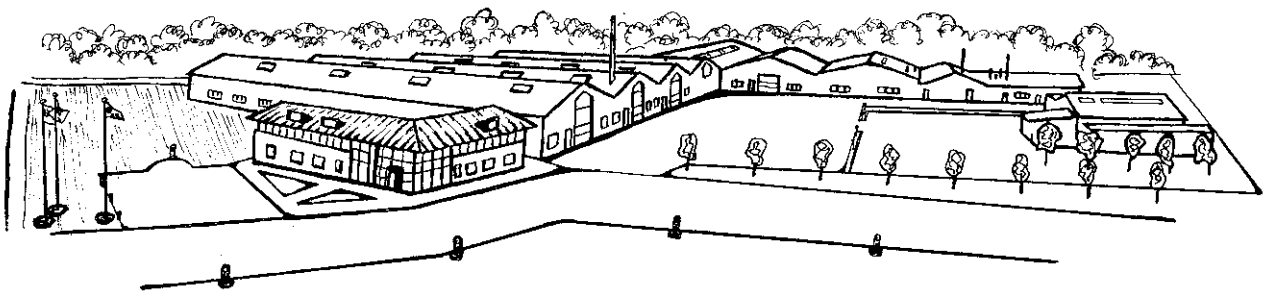

The design is subject to modification without notice.