

UK

HE-VA

Operating Instructions Spare Parts List Declaration of Conformity

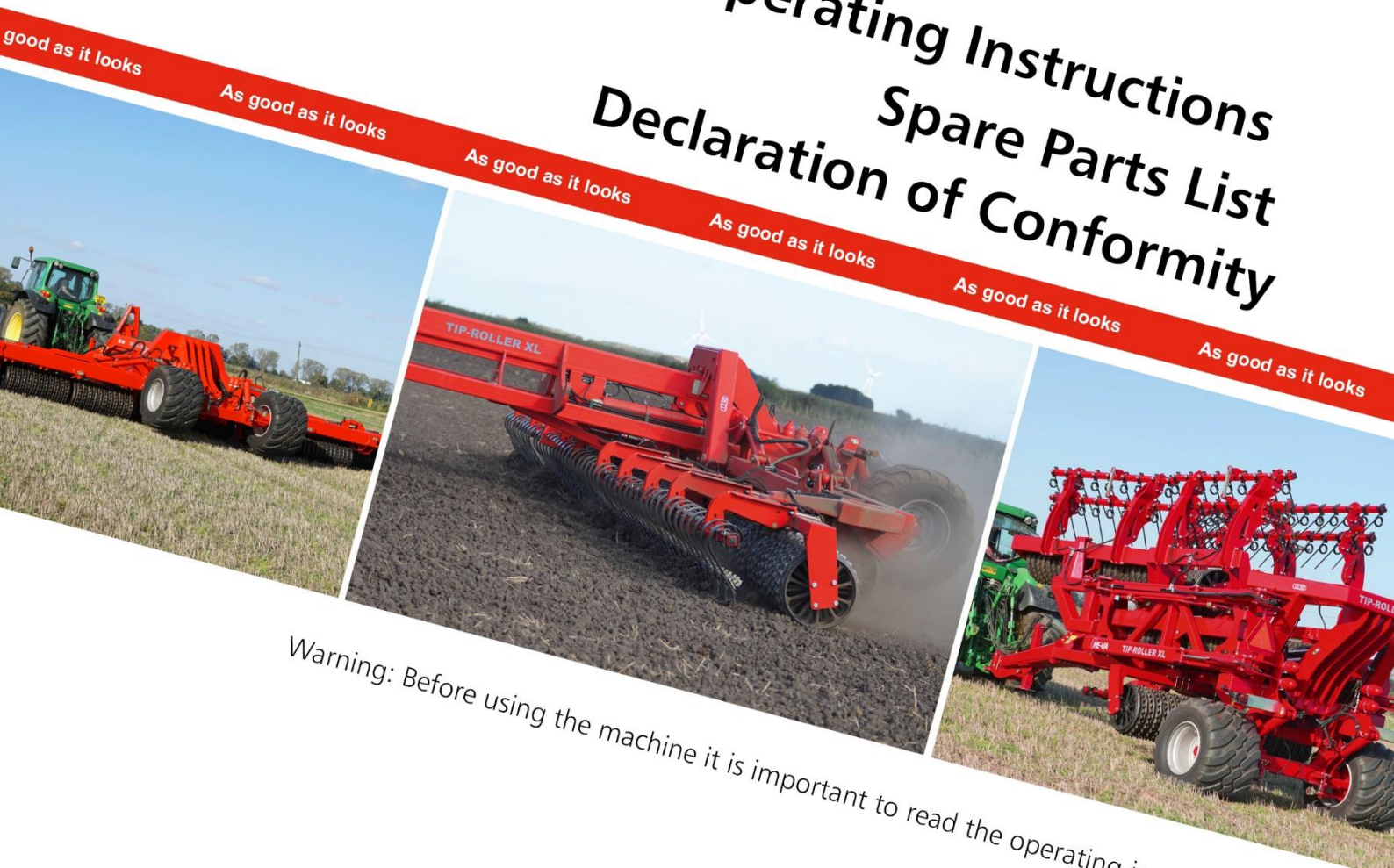

Warning: Before using the machine it is important to read the operating instructions.

Tip-Roller XL
12,30 m - 15,3 m

Manual no. 8000311-03 140121



N. A. Christensensvej 34
DK-7900 Nykøbing Mors
Tel: 97724288
Fax: 97722112
www.he-va.com

Contents

EC DECLARATION OF CONFORMITY	3
Description of the machine	5
Delivery Check	5
Specifications	6
Operating Instructions.....	6
Warning.....	7
Tip XL roller folding instructions	7
He-Va SAT-System.....	9
Spring Board.....	9
Rolling.....	10
Safety at the Tip-Roller XL	10
Safety Instructions, regarding Hydraulic System	12
Safety and other markings on the machine	12
Maintenance	14
Lubrication	14
Spareparts list.....	16
Outer wing right / left.....	16
Outer roller section.....	16
Side section right.....	17
Side section left	18
Side roller section right / left and middle section.....	20
Chassis and drawbar.....	22
Drawbar for lift. 630757077 Cat. 3 / Cat. 4 (Additional).....	24
Middle frame	25
Wheel frame w/brake	26
LED –light bar.....	28
Light kit: El. diagram	29
Spring-Board w/ fixed mounted wearing points and traverse locking system.....	30
Spring-Board mounting w/easy change	31
Ø16 mm tine for strigle	32

Roller section.....	33
Cambridge- and Corrugated rings overview	34
Rings at support bearing.....	35
Star- and Crosskill rings overview	35
Support bearing	36
Support bearing with rubber (additional equipment)	37
Hydraulic.....	39
Side sections	39
Weight distribution system, outer- and center section	40
Spring-Board	42
Tipping cylinder	44
Support leg	46
Disposal.....	46



EC DECLARATION OF CONFORMITY

in accordance with the EU Machinery Directive 2006/42/EC
applicable as from December 29th 2009:

HE-VA ApS
N. A. Christensensvej 34,
DK-7900 Nykøbing Mors

hereby confirms that the following machine has been manufactured in accordance with the Council
Directive 2006/42/EC.

In addition, the following harmonized EU standard has been used:
ISO 12100 Machine safety, general design principles, risk assessment and risk reduction.

The declaration comprises the following machines:

Tip-Roller XL 12,3m – 15,3m

Nykøbing the 29th of December 2018

A handwritten signature in black ink, appearing to read 'Villy Christiansen', written over a horizontal line.

Villy Christiansen

The undersigned is furthermore authorised to compile technical documentation for the above
machine.

Description of the machine

The Tip-Roller XL is a 5-section hydraulic roller, with a 2-section wheel frame. The main purpose of the divided wheel frame is to reduce the radius when turning in transport position and lower height in transport position. The roller sections is mounted in a middle suspension. This construction gives the sections an independent movement from each other, which makes the roller able to follow the surface in uneven or hilly areas.

The roller is mounted with He-Va SAT-system which is a weight distribution system to reduce weight from the chassis and middle section roller and transfer weight evenly to the wing sections.

Before operating the Tip-Roller this operating and safety instruction must be studied very carefully.

Delivery Check

Check the roller for any damages. Check the hydraulic hoses for cuts and squeezing damages. Check also the other hydraulic components, are not damaged during transport. Check that the frame construction has not been damaged. You should also check that the roller blocks have not been exposed to impacts, which may have damaged the cast roller rings or the double-sealed ball bearings.

**Finally check that the transport wheels are tightened and OK.
Check the air pressure in the tyres: approx. 3.8 bar / 55 psi**

Transport Brackets

At delivery the machine is mounted with brackets for hoisting gear, which is not painted.

These brackets is for attachment of chains or straps, when loading or unloading the machine from the transport vehicle, and they must be dismantled before use.

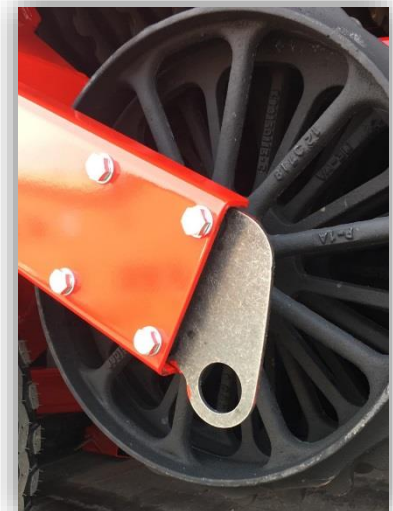

Specifications

5-section hydraulic wheel-mounted field roller with free movability in all sections. Used for rolling of stones and packing of the top soil. The roller is available with a working width of 12,3 m or 15,3 m and with five different ring types: Cambridge-, Cam-, Star-, 2D wave-, and Crosskill rings.

Technical Specifications

Work Width	12,3 m	15,3 m
Total Width in workposition	12,65 m	15,65 m
Length	8,6 m	8,6 m
Width in transportposition	3,0 m	3,0 m
Hight in transportposition		
Pressure on pintle eye in transport position (% of total weight)	ca. 40 %	ca. 40 %
Wheel assembly, standard	710/40Rx22,5	710/40Rx22,5
Tyre pressure	3,8 bar / 55 psi	
Oil pressure	min. 150 bar	
Hydraulic outlets	4 double-acting (tipping – folding – support leg – SAT system) Plus 1 DA. per each additional equipment (Spring Board – tine)	
Quick-couplings, standard	Sterling type E 402	
Hydraulic oil: system is filled with	Hydro Texaco HD32	

Operating Instructions

Attachment

On delivery, the roller is in transport position. When the roller is attached, check that the towing hook height is 400-500 mm. Reverse the tractor, and put in and **secure** the draw bolt.

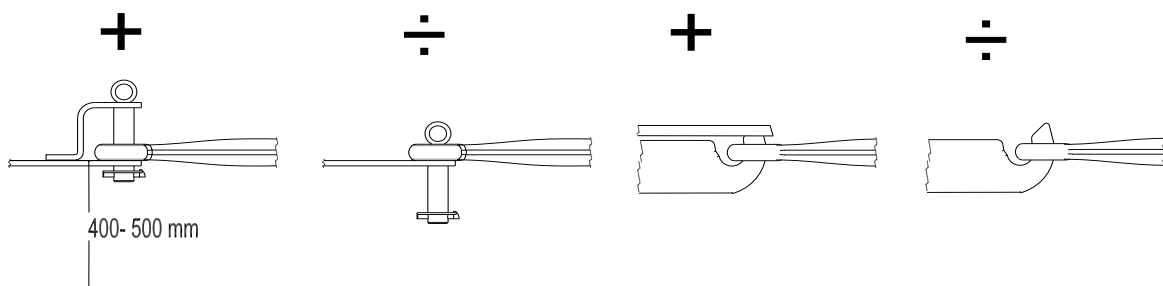

IMPORTANT: Check that the male quick couplings of the hydraulic hoses, mounted by the factory, fits the female end of the tractor.

Now connect the hydraulic hoses, in the hydraulic outlets of the tractor. The Hydraulic hoses are marked in pairs with colour coded cable ties.

Wing folding	Tip frame and wheels	SAT-system center and outside wings	Jack stand	Spring Board
Blue	Red	Yellow	Black	Green

Start engine and raise the Jack stand.

Warning

- Do never transport the roller at any time when the middle section roller is decended to ground and wing sections are in transport positions.
- Drive carefully when driving off an on road/field. Be aware of ditches along the road and holes in dirt tracks due to center of gravety is reasonable high.
- Watch out in traffic to be sure there is space enough for the turning radius when turning.

Tip XL roller folding instructions

CAUTION! The machine has a high centre of gravity, only fold the machine on flat stable ground, check for sufficient space and any overhead obstructions. To avoid making the machine unstable, ensure the valve stays actuated until the function being operated has reached the end of its stroke. The tractor must be able to move freely.

Unfolding

- Step 1.** Lower SAT-system pressure until wings tip outwards approx.. 50 bar, fig. 1.
- Step 2.** Move the rear wheels back and tip the frame fully up clear of the transport cradles, fig. 3.
- Step 3.** Fold the wings fully out, fig. 2.
- Step 4.** Tip frame fully down until frame it is latched and the rear wheels are lifted from the ground, fig. 3.
- Step 5.** Set the SAT-system pressure (see page 9), the pressure should then be even on all roller sections, fig. 4.

Folding

- Step 1.** Lower the SAT-system pressure until center roller is fully raised, less than 50 bar.
- Step 2.** Tip frame fully up.
- Step 3.** Fold wings in.
- Step 4.** Lower the frame onto transport cradles and keep the valve actuated until the rear wheels have moved fully forwards.
- Step 5.** Raise the SAT-system pressure until the outer wings tip towards the center of the machine.



He-Va SAT-System



Figure 4

To activate the He-Va SAT-system (weight distribution system), slowly raise pressure in SAT-system (figure 4), **until pressure is up to 50 – 60 bar (figure 5)**. This will release weight from the inside wing section roller and distribute some weight to the outer wing and middle section roller. The individual weight of the rollers will hereby be fairly even. **Despite this the driver must pay attention to the fact, soil packing can be various, depending on different soil types.**

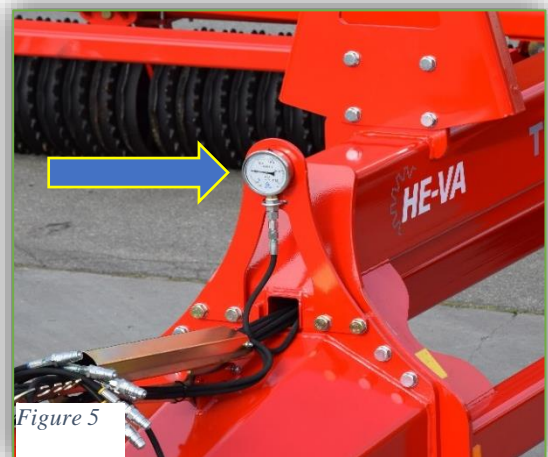

Figure 5

Spring Board

The spring board is adjustable by the means of the cylinders mounted in the horns for the spring board bar.

If the roller is mounted with two Spring-Board bars, it is possible to adjust the angle to the surface individually by the top link (figure 6).



Figure 6

Rolling

Speed: max. 10 km/h.

When turning, drive in wide curves as far as possible. The turning should be performed no sharper, than all roller rings are still rotating forward.

Only lower the wheels when making ready for transport position.

Do not drive over any large stones, which are not moveable.

WARNING:

Do always make sure that no persons is present at the machine working area, when folding it out and in.

Safety at the Tip-Roller XL

Do not operate the machine, if any people** are at risk in the dangerous area.*

When persons are at risk in the dangerous area (e.g. when doing adjustments, maintenance or connect or disconnecting), the following points must be met:

1. Lower the machine on solid ground
2. Hydraulics must be relieved.
3. Tractor must be turned off, and the key removed.
4. Driver must be aware of, when operating that there is no persons at risk in the dangerous area.

* **Dangerous area: At the machine and underneath it, and in a distance of 4 m from it.**

** **People at risk: Any person, who is completely or partially in the dangerous area.**

Most accidents when operating the machine, transporting and doing maintenance occurs, when avoiding the most simple safety regulations.

For this reason, it is of highest importance, that any person who is operating the machine, strictly follows the safety regulations and other instructions, which belongs the machine.

The machine must only be operated, maintained and fixed by persons, who is confidential with and skilled for this work and is aware of moments of danger, which can occur.

Controle tightening:

- of hub bolts, 386 Nm according to specifications
- flange for towing eye, **6 pc of bolts** 541 Nm

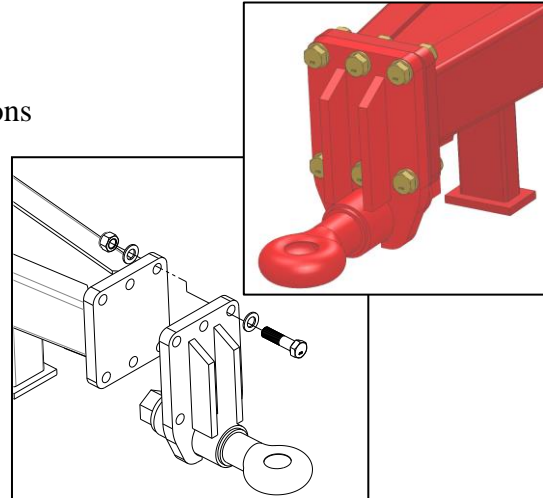

ATTENTION!! Rotating parts and clothes in a loose condition, is a dangerous combination.
IMPORTANT!! It is strictly prohibited for any person to take place on the frame or chassis of the machine, when it is either operating or the tractor is idling.

INSTRUCTIONS FOR TRANSPORT AT PUBLIC ROADS:

Before transport at public roads, make sure that the attachment of the implement to the tractor, is in accordance with the local rules and regulations in force (permitted total weight, permitted axel load, transport width, lights and warning signs).

FRONT AXEL LOAD:

When the implement is attached and at maximum load, the tractors driving properties must be ensured. Check that the front axel is sufficiently loaded. The front axel load must be at least 20% of the tractors weight. Permitted axel load and total weight for the tractor must be respected.

NB! The driving, controlling and braking properties are affected by the attached implement.

Safety Instructions, regarding Hydraulic System

1. The highest allowable pressure, is 225 bar.
2. It is recommended to mark the hydraulic connections between the implement and tractor, to avoid incorrect operation!
3. When checking for hydraulic leaks, suitable safety gear must be used due to danger. (Safety goggles , gloves, etc.)
At high pressure, hydraulic oil can penetrate the skin and cause serious injuries.
At injuries, consult a doctor immediately. **RISK OF INFECTION!**
4. Before any work at the hydraulic system, the implement must be lowered to solid ground. Pressure must be relieved, engine stopped, and ignition key removed.
5. Check the hydraulic hoses on a regular basis, however, every six months as a minimum due to any cracks, wear and tear, etc. Replace any defective hoses immediately.
6. Hydraulic hoses last for no more than 5 years.
New hydraulic hoses must be identical to the manufacturer's specifications.

Oil, type Hydro Texaco HD 32 has been filled in the hydraulic system

Safety and other markings on the machine

Several markings are located at your machine, which contains **safety regulations** and other instructions to inform about correct operating.

Please read these instructions carefully, and make the driver aware about the markings and **safety regulations** in this Operating Instructions. Keep the markings clean and readable. If they are not, they must be replaced.

Safety – and other markings on the machine

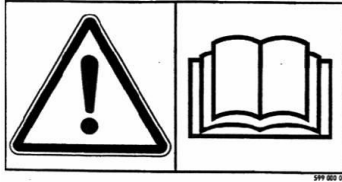

Study the Operating Instructions thoroughly before any operation of the machine and observe all safety instructions.

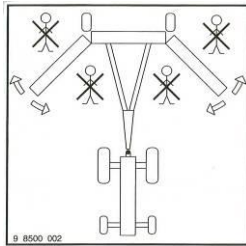

Take care that no persons are within the machine's hazardous area during the unfolding and folding procedure.



Plate with number and year of manufacture.

**HUSK - PLEASE NOTE -
ACHTUNG - ATTENTION**
EFTERSPÆND BOLTE
TIGHTEN UP THE BOLTS
BOLZEN NACHZIEHEN
RESSERRER LES BOULONS

Tighten up the bolts regularly. If this is not performed, our warranty obligations will no longer apply.

Maximum torque in Nm. w/lubricated thread			
Metric thread	Quality 8.8	Quality 10.9	Quality 12.9
M10x1,5	47	65	79
M12x1,75	81	114	136
M14x2,0	128	181	217
M16x2,0	197	277	333
M18x2,5	275	386	463
M20x2,5	385	541	649
M22x2,5	518	728	874
M24x3,0	665	935	1120
Hub bolts M18x1,5 fine thread	433 Nm		
Hub bolts M22x1,5 fine thread	803 Nm		

Maintenance

- After 10 hours of operation, tightening of wheels, bearings and stop rings must be done.
- Hoses, fittings and cylinders must be checked for any leaks and retightened.
- When the season is done the roller must be cleaned, lubricated and a thin layer of oil sprayed on all painted parts.
- Glossy piston rods must be protected by grease.

Lubrication

At every 10 hours operation: - every roller sections suspension

At every 30 hours operation: - wings bushings hinged to wheel frame

- bearings

- cylinders

- wheel frame bushings hinged to chassis

- wing frame bushings hinged to chassis

Once a year: - the support leg

IMPORTANT:

Bearings must only be lubricated with 1-2 strokes, otherwise the sealing rings can be released.

 = Greasenipples

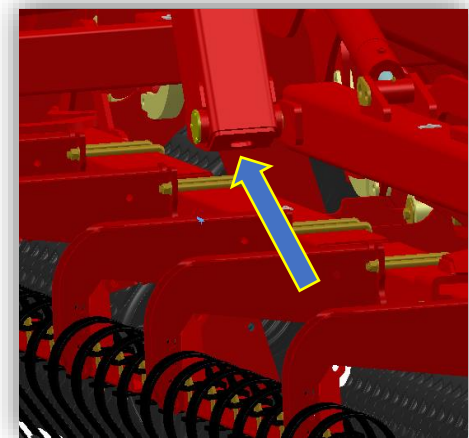
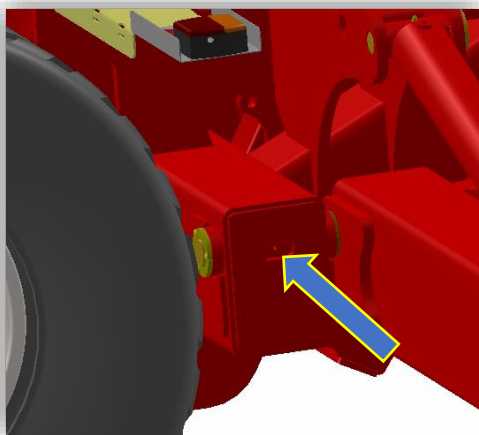
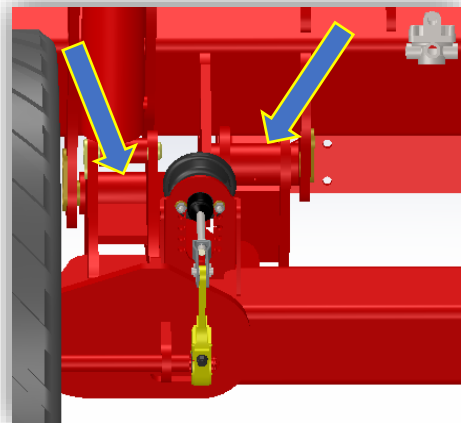
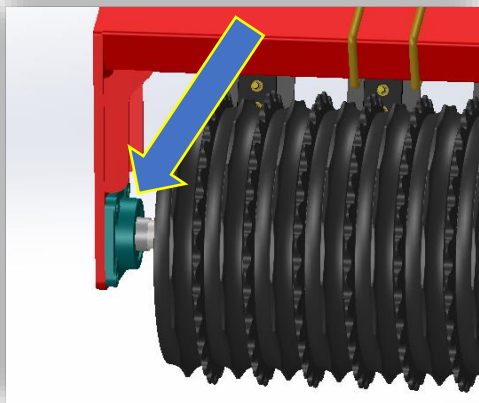
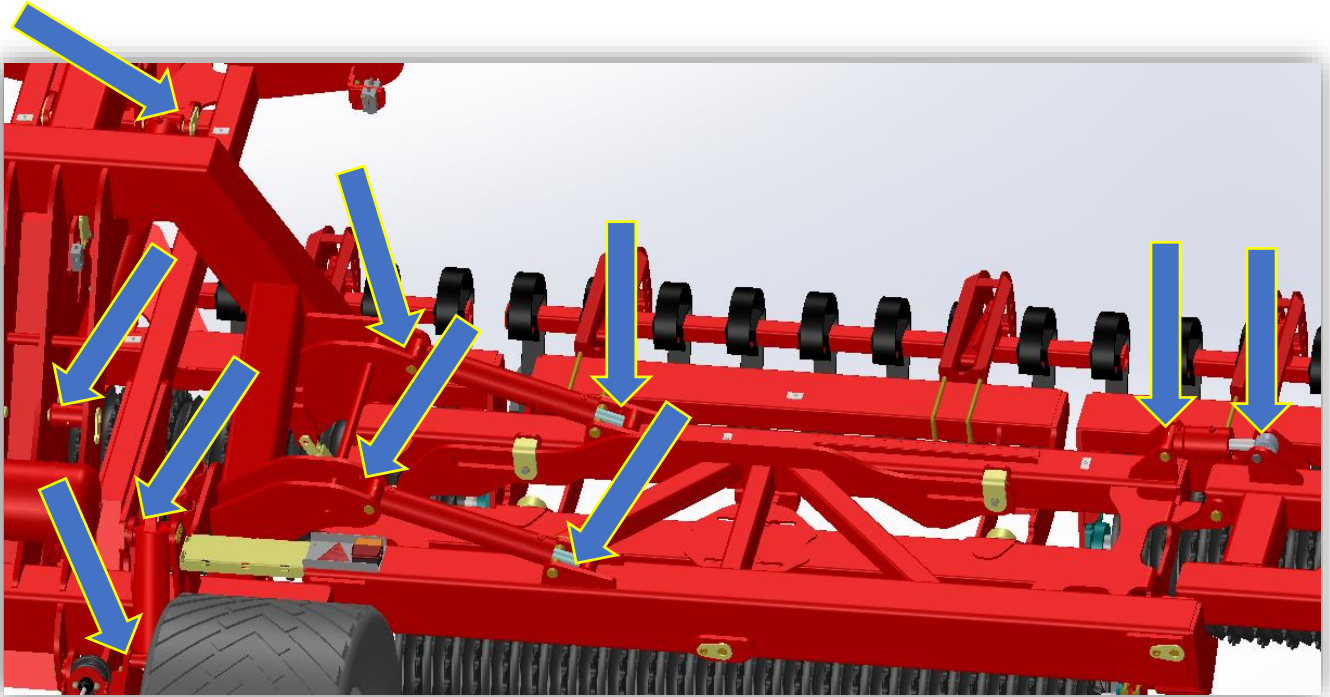

Spareparts list

Outer wing right / left

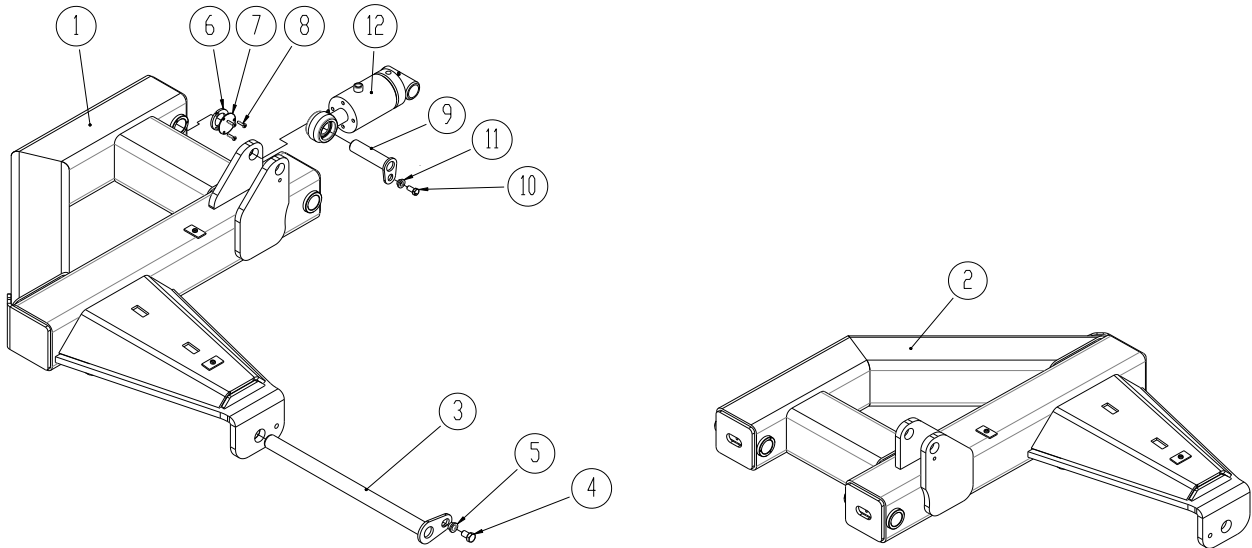

Outer roller section

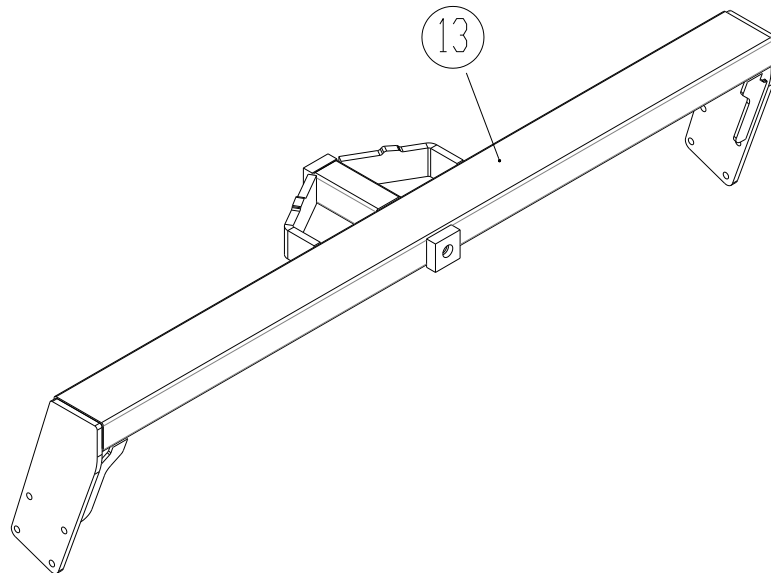

Pos.	Part no.	Description	12,3m	15,3m
1	630850260	Outer wing right	1	1
2	630850071	Outer wing left	1	1
3	69440615N	Pin Ø40 L=615 New model	1	1
4	0235760	Bolt M16x25mm, 8.8 fzb	1	1
5	630532700	Lock bushing for pin head	2	2
6	1215096	Lock plate for Ø40 mm bushing	2	2
7	1215107	Cover for lock plate Ø40 mm bushing	2	2
8	0227545	Insex M6x25 BH 10.9 FZB DIN7380	6	6
9	69435138G	Pin Ø35 L=140	2	2
10	690101101	Bolt M12x25 8-8 w/glue	2	2
11	630532600	Lock bushing for pin head	2	2
12	7345020	Cylinder Ø100/40 x 50 Ø35/Ø35	2	2
13	630850070	Outer roller section right / left	2	2

Side section right

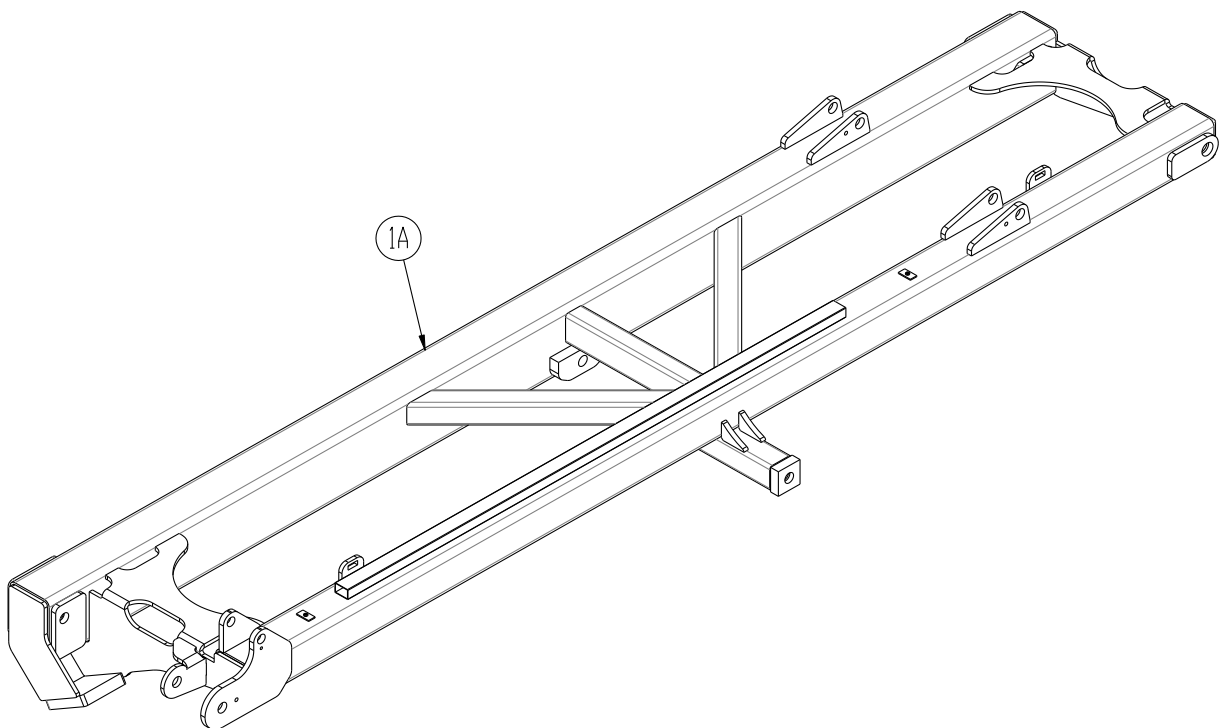

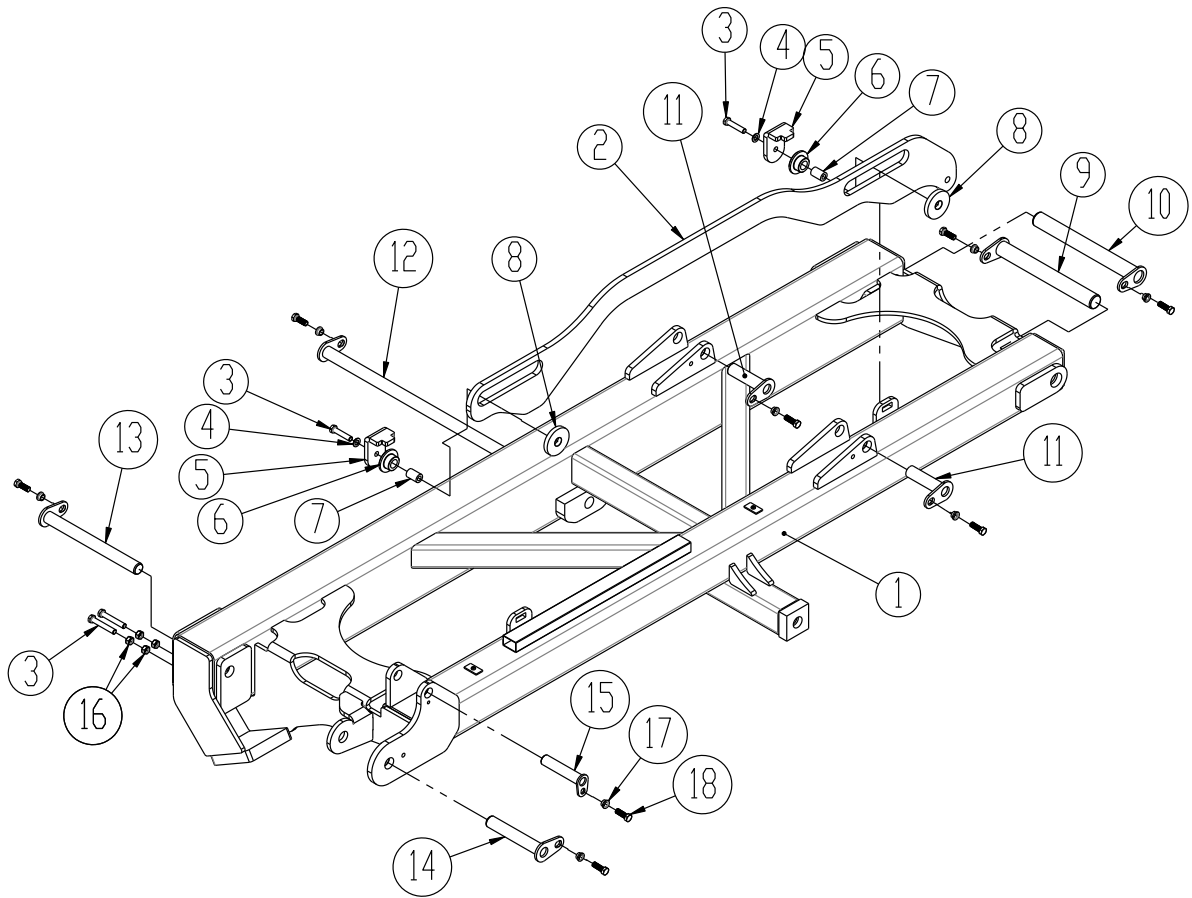

Side section left

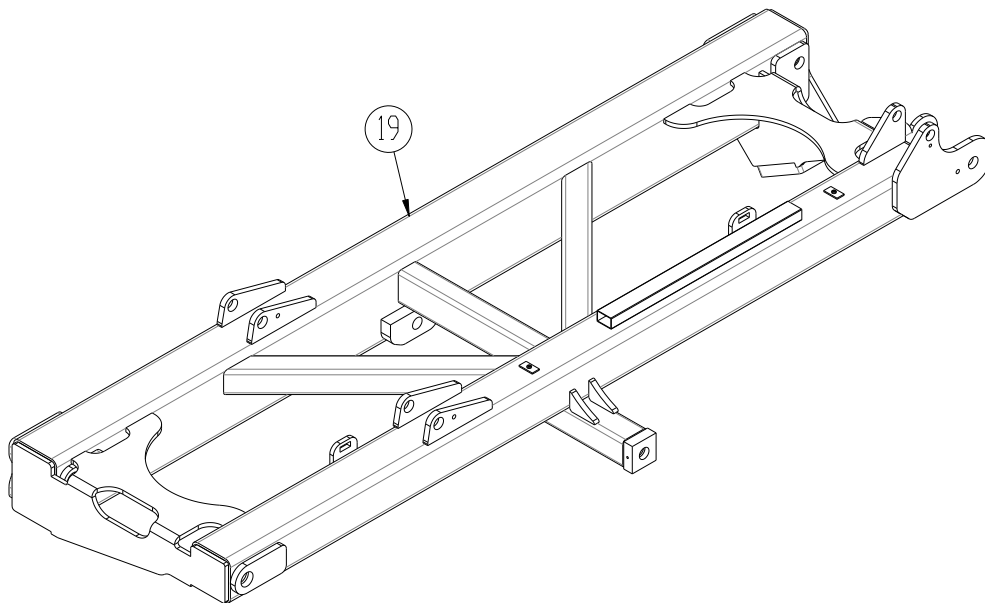

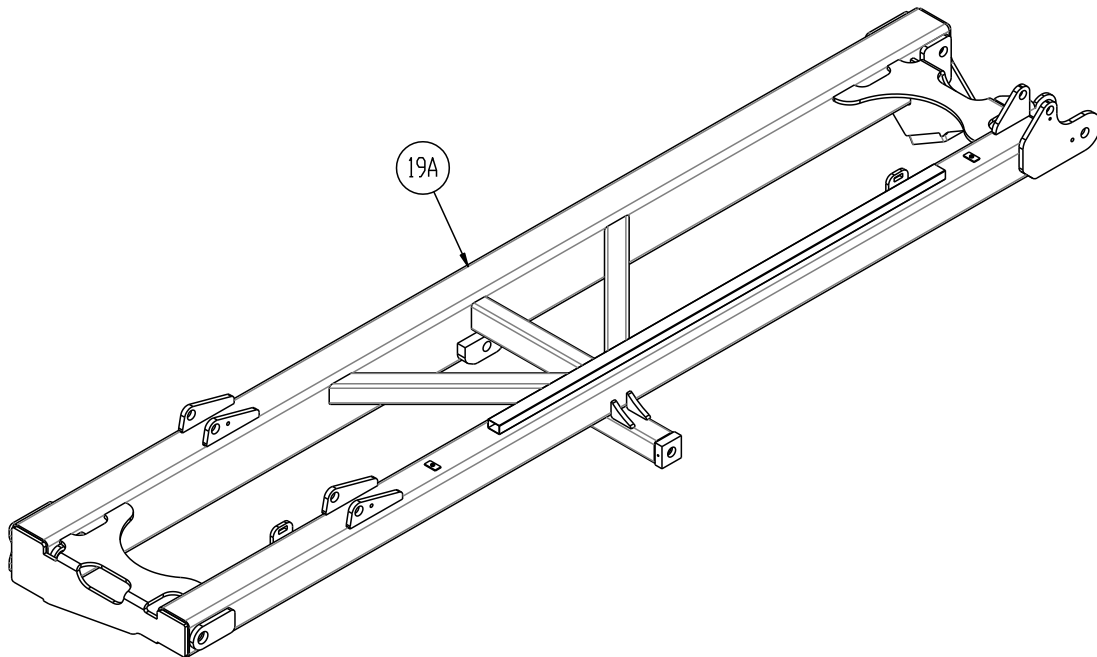

Pos	Part no.	Description	12,3m	15,3m
1	630850088	Side wing right, welded	1	
1A	1215127	Side wing right, welded		1
2	630850103	Steel plate 20mm	2	2
3	690103282	Bolt M16x100 10.9	4	4
4	0272290	Faceted washer Ø16 – DIN 125B	4	4
5	630850104	Steel plate 15 mm	4	4
6	630850107	POM black, Ø80 mm	4	4
7	630850098	Centerless-grinded Ø30 CK45 L=45	4	4
8	630850105	Steel plate (circular)	4	4
9	69450430G	Pin Ø50 L=430	2	2
10	69450455G	Pin Ø50 L=455	2	2
11	69440155N	Pin Ø40 L=155	4	4
12	69440830N	Pin Ø40 L=830	2	2
13	69440415N	Pin Ø40 L=415 Ny model	2	2
14	69440240N	Pin Ø40 L=240	2	2
15	69435170G	Pin Ø35 L=170	2	2
16	690112005	Nut M16	8	8
17	630532700	Lock bushing for pin head	16	16
18	0235800	Bolt M16x45 8.8 fzb	16	16
19	630850270	Side wing left, welded	1	
19A	1215117	Side wing left, welded		1

Side roller section right / left and middle section

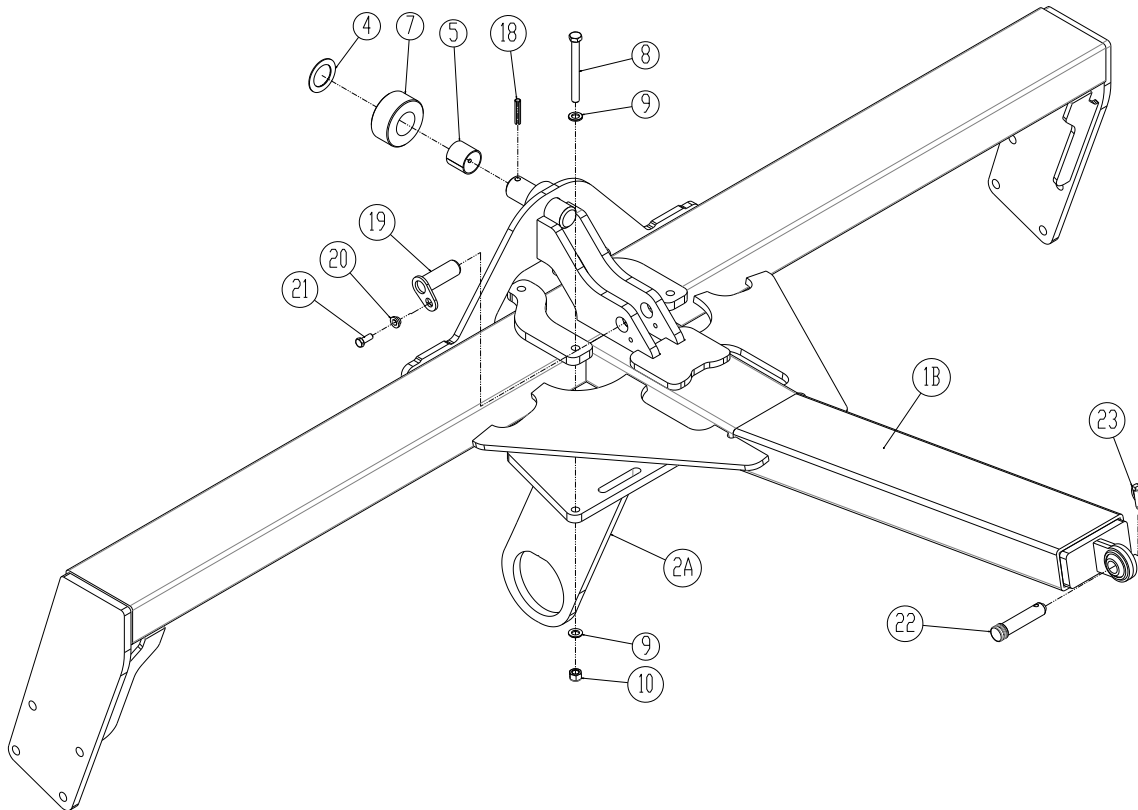
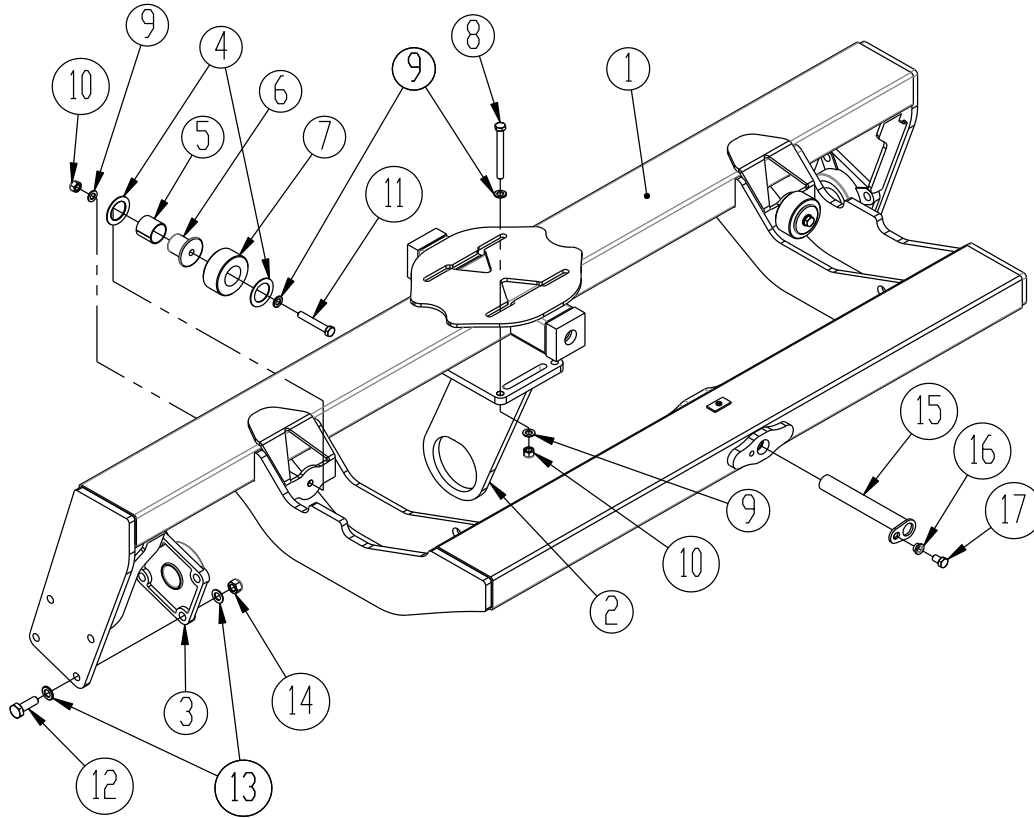

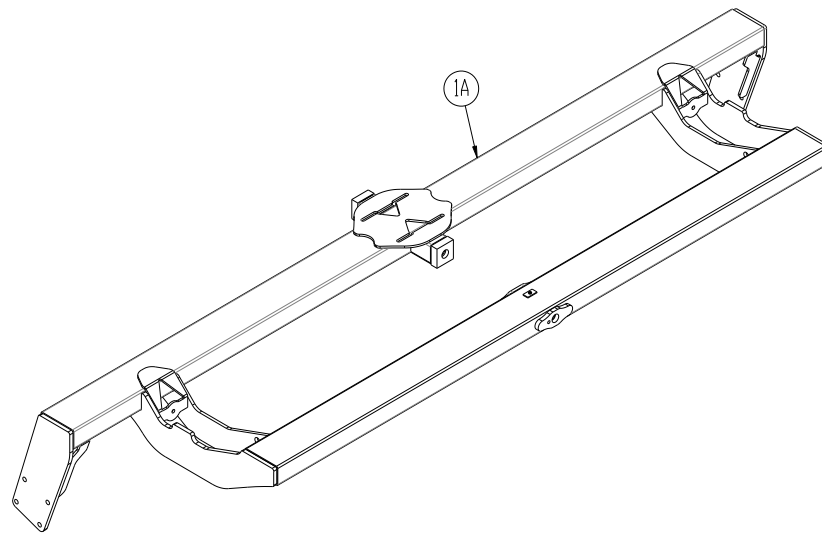

Pos.	Part no.	Description	Sidesecc.	Middle
1	630850083	Side roller section, right / left 12,3 m	2	-
1A	1215119	Side roller section, right / left 15,3 m	2	-
1B	630850095	Middle roller section	1	1
2	630850263	Bearing for support, side wings and outer wings	4	-
2A	630850271	Bearing for support, center section	-	1
3	690140808	Bearing UCF 312 (Ø60) 0478971	2	2
4	690140712	Circular plate Ø52/Ø78x2	4	1
5	690140710	Bushing as bearing Ø50/55 L = 50 mm	2	1
6	630850227	Centerless-pin Ø80 CK45 L = 60 mm	2	-
7	630850237	Roller Ø110 L = 50 mm	2	1
8	0235955	Bolt M16x160 8.8 fzb	4	4
9	0272290	Faceted washer Ø16 – DIN 125B	12	8
10	0264090	Safety nut M16	6	4
11	0235900	Bolt M16x100 8.8 fzb	2	-
12	0236130	Bolt M20x60 8.8 fzb	8	8
13	0272310	Faceted washer Ø20 DIN125B	16	16
14	0264110	Safety Nut M20	16	8
15	1145492	Pin Ø40 L=310 mm	8	-
16	630532700	Lock bushing for pin head	1	-
17	0235760	Bolt M16x25 mm	1	-
18	690131171	Roll pin Ø12 x 60 mm	1	1
19	69435100G	Pin Ø35 L=100 mm	-	1
20	630532600	Lock bushing for pin head	-	1
21	0235340	Bolt M12x30 mm	-	1
22	69528096J	Pin Ø28 L=122 mm	-	1
23	690134004	Ring Pin	-	1

Chassis and drawbar

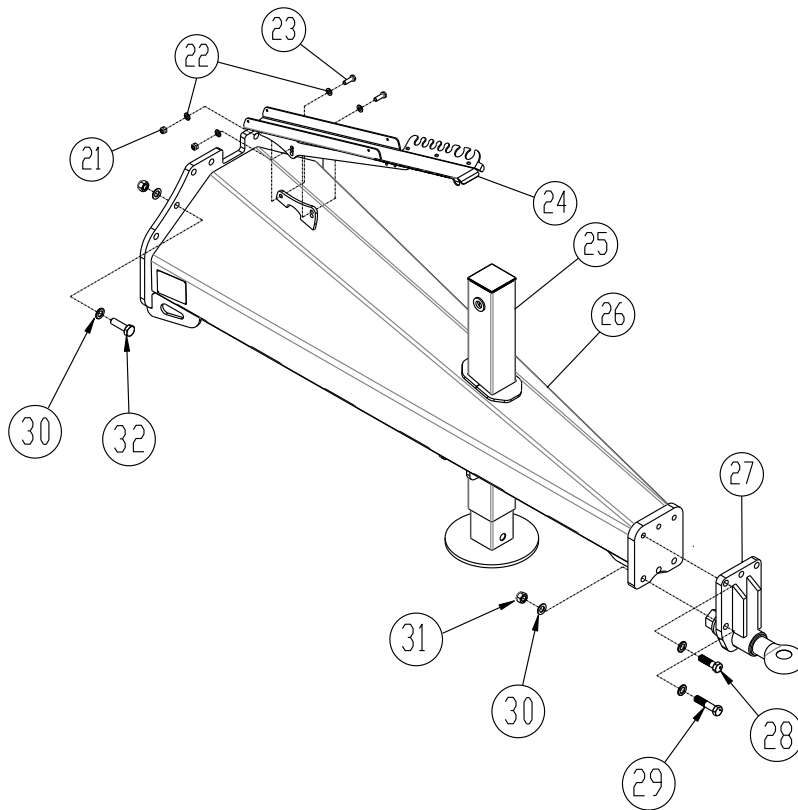
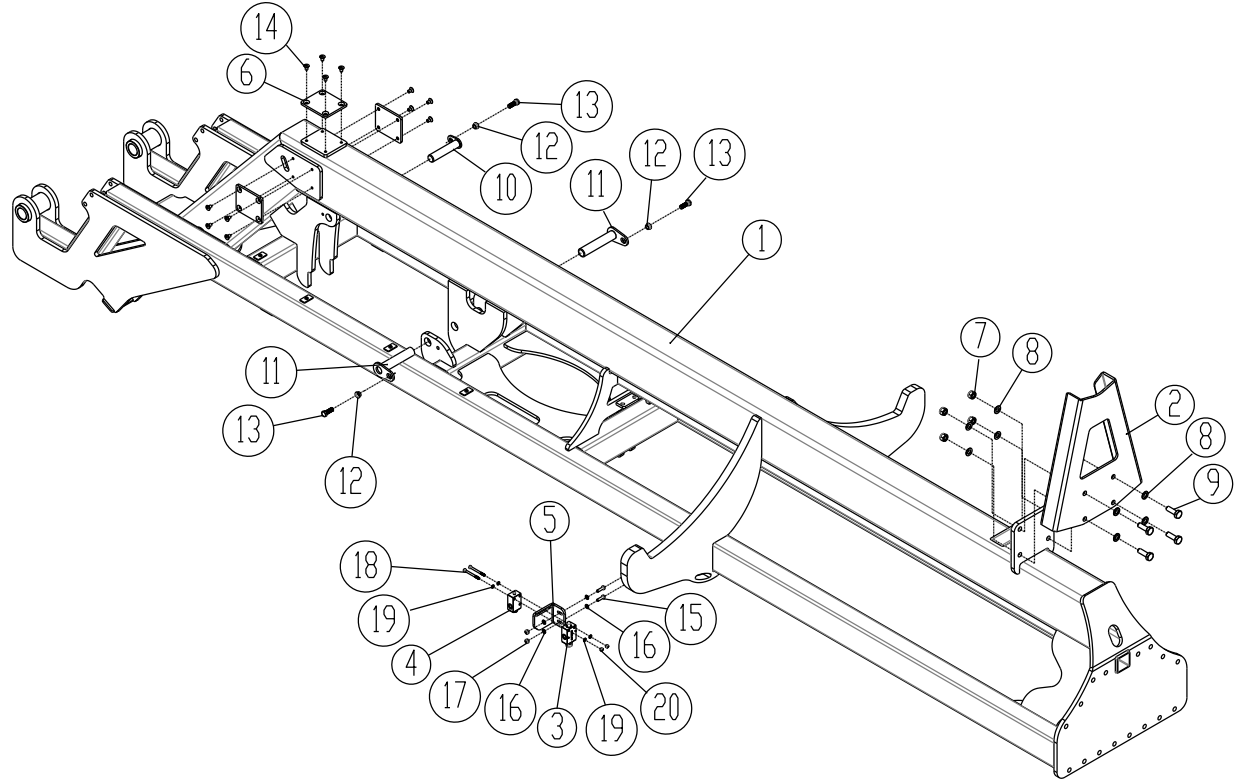

Pos.	Part No.	Description	12,3 m	15,3 m
1	630850130	Chassis, welded	1	-
1	1215114	Chassis, welded	-	1
2	630850228	Tower	1	1
3	690207100	End stop valve FC10NA	1	1
4	690207101	End stop valve FC10NC	1	1
5	630850292	Bracket for end stop valve	1	1
6	630850168	Wearing plate	3	3
7	0264110	Safety nut M20 DIN 985	4	4
8	0272310	Faceted washer Ø21x3 mm	8	8
9	0236130	Bolt M20x60 8.8	4	4
10	69435168G	Pin Ø35 CK 45 L = 168 mm	1	1
11	69440200N	Pin Ø40 CK 45 L = 200 mm	2	2
12	630532700	Lock bushing for pin head	3	3
13	0235800	Bolt M16x45 mm 8.8	3	3
14	0228095	Undersænk- M12x20 mm 8.8 fzb DIN 7991	12	12
15	0235060	Bolt M10x35 mm fzb 8.8	2	2
16	0272260	Faceted washer Ø10	4	4
17	0264060	Safety nut M10	2	2
18	690103061	Bolt M8x90 mm 8.8	2	2
19	0272050	Faceted washer Ø8,4x1,6	4	4
20	0264050	Safety nut M8	2	2
21	0264070	Safety nut M12, fzb DIN 985	2	2
22	0272270	Faceted washer 12mm, fzb DIN 125B	4	4
23	0235350	Bolt M12x35 mm, fzb 8.8	2	2
24	7345006	Holder for hoses, model Large	1	1
25	690141105	Hydraulic support leg, 5772 kg	1	1
26	1215150	Drawbar, welded	1	1
27	630757017	Drawbar, complete	1	1
28	690103173	Bolt M20x70 mm, 10.9	3	3
29	690103161	Bolt M20x90 mm, 10.9	3	3
30	0272310	Faceted washer Ø20 DIN125B	41	41
31	0264110	Safety nut M20	19	19
32	0236150	Bolt M20x70 mm,	16	16

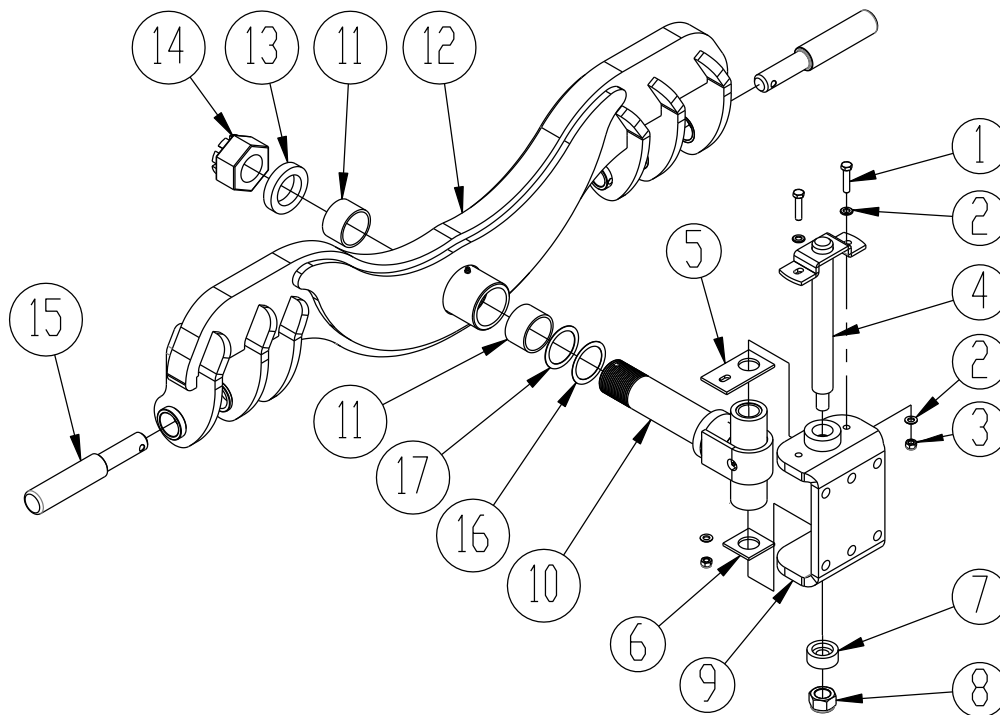
Drawbar for lift. 630757077 Cat. 3 / Cat. 4 (Additional)

Pos.	Part no.	Description	Pc.
1	0235390	Bolt M12x55 mm, 8.8 fzb	2
2	0272270	Faceted washer 12 mm, fzb Din 125B	4
3	0264070	Safety nut M12, fzb DIN 985	2
4	1127870	Pin, vertical complete	1
5	1128390	Steel plate 70x6x130, Quality SB27W12CB	1
6	1127990	Steel plate 70x6x70, Quality SB27W12CB	1
7	1127900	Bushing Ø60x25 mm, Quality 50	1
8	0264155	Safety nut M30	1
9	1145335	U-bracket	1
10	630757076	Axel, horizontal	1
11	0475450	I-pressure bushing EG Ø80/70x50mm	2
12	630757078	Draw bar, welded	1
13	7420000	Bushing Ø100x12mm, st. 50 (To be used is no. 7420000 or	1
13	7420001	Bushing Ø100x15mm, st. 50 no. 7420001 depending on space)	1
14	0262500	Nut M64x4 KL6 DIN 935-1	1
15	69537273C	Round Steel E 360, Quality 70-2	2
16	690140656	Shim ring Ø70/Ø90x0,5mm DIN988, no. depending on tolerences	0 - 3
17	690140654	Shim ring Ø70/Ø90x1,0mm DIN988 no. depending on tolerences	0 - 3

Middle frame

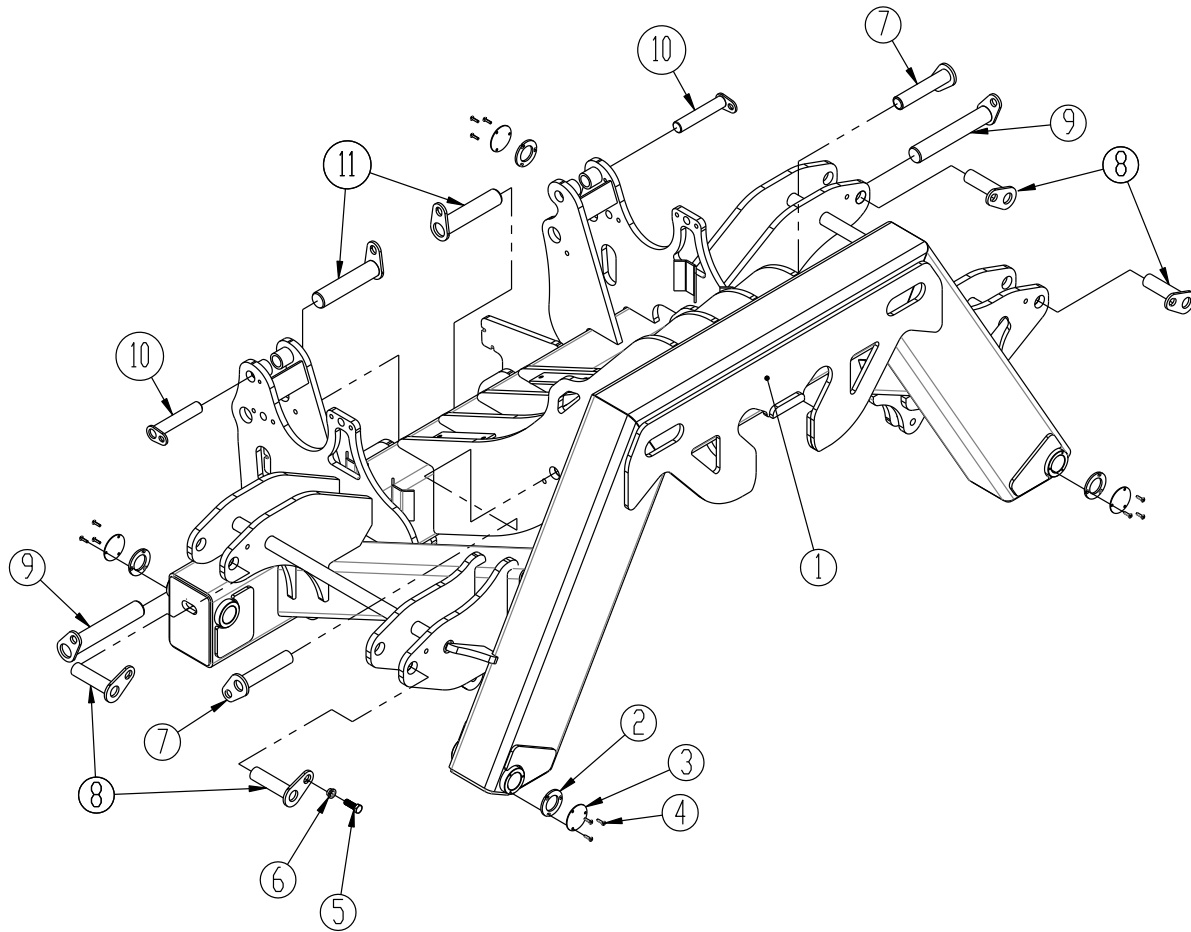

Pos.	Part no.	Description	12,3 m	15,3 m
1	630850106	Middle frame	1	1
2	121596	Lock plate for Ø40 mm bushing	4	4
3	1215106	Cover plate for Ø40 mm bushing	4	4
4	0227545	Insex. M6x25 BH 10.9 FZB DIN7380	12	12
5	0235800	Bolt M16x45 mm 8.8	12	12
6	630532700	Lock bushing for pin head	12	12
7	69440200N	Pin Ø40 CK 45 L = 200 mm	2	2
8	69440155N	Pin Ø40 CK 45 L = 155 mm	4	4
9	69450295G	Pin Ø50 CK 45 L = 295 mm	2	2
10	69435185G	Pin Ø35 CK 45 L = 185 mm	2	2
11	69450230G	Pin Ø50 CK 45 L = 230 mm	2	2

Wheel frame w/brake

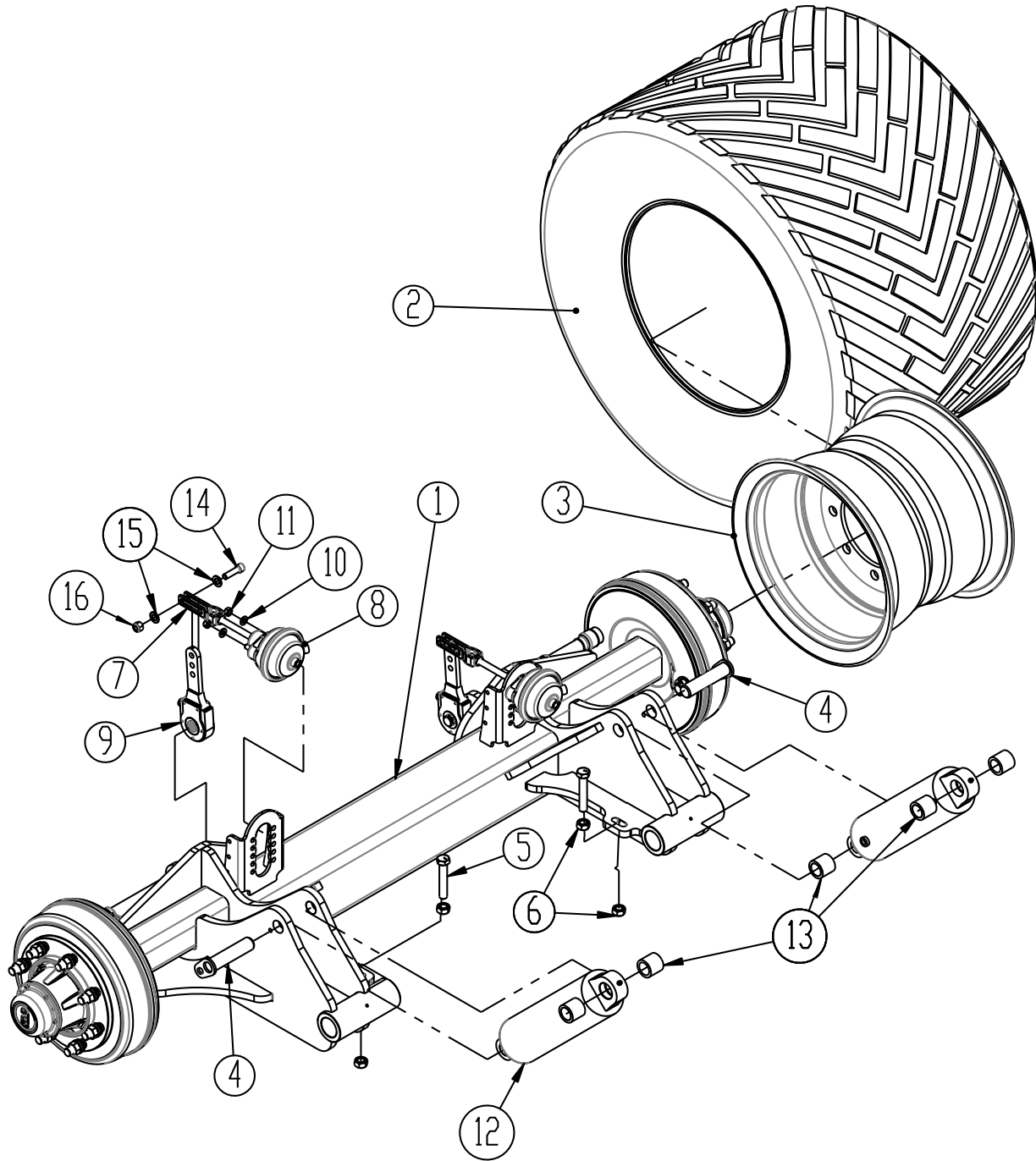

Pos.	Part no.	Description	Pc.
1	630850351	Wheel frame w/brake	1
2	0396910	Tire 710/40R22,5 FL630	2
3	0396900	Rim 8/M27-221-275	2
2+3	0396920	Wheel complete, right 710/40R22,5	1
2+3	0396930	Wheel complete, left 710/40R22,5	1
4	69435148G	Pin Ø35 L = 148 mm	2
5	0238870	Bolt M20x110, 10.9 fzb	2
6	690112009	Nut M20	4
7	7297509	Mounting kit w/long bars	2
8	7297508	Pneumatic membranecylinder 12", no U-piece for mounting	2
8	7345014	Hydraulic brake cylinder BR25SL	2
9	7297528	Brake arm, adjustable	2
10	0272270	Faceted washer 12 mm, fzb DIN 125B	4
11	0394861	Hub nut M12x1,5	4
12	7345042	Cylinder 110/40x285	2
13	630850185	Bushing 50x7 L = 45 mm	6
14	661042217	Insex 6-kt M14x50 12.9	2
15	690117013	Faceted washer ø16	4
16	690113008	Safety nut M14	2
	690141160	Wheelhub complete	2

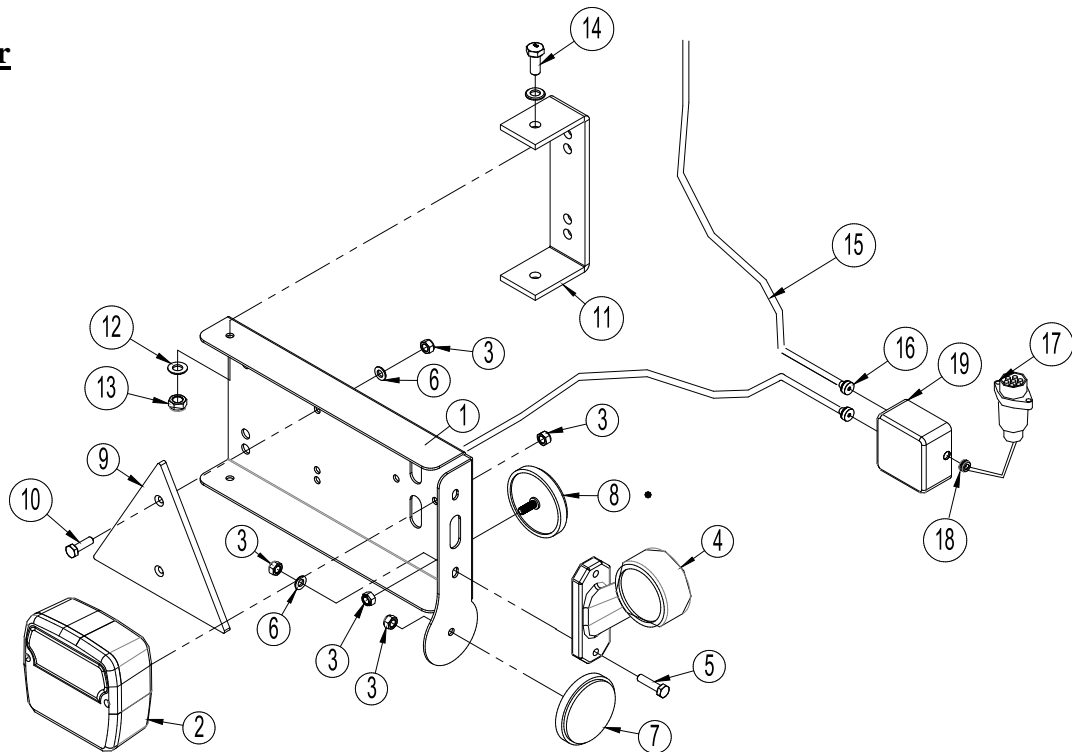
LED –light bar

Pos.	Part no.	Description	Pc.
1	7357505	Lightbox (L)	1
	7357508	Lightbox (R)	1
2	7357504	Rear light	2
3	0264030	Locking nut M5	16
4	7357507	Marking lights (L)	1
	7357509	Marking lights (R)	1
5	0234340	Bolt M5x25	4
6	0272240	Facet plate Ø5	8
7	0656240	Reflex, yellow	2
8	0656250	Reflex, white	2
9	690160017	Reflex, red	2
10	0234330	Bolt M6x20	4
11	7357516	Bracket	2
12	0272250	Facetskive Ø8	16
13	0264050	Locking nut M8	8
14	0234750	Bolt M8x20	4
15	690160080	Cable 5 x 1mm ² (Inform about lenght by ordering sparepart)	
16	7357545	Rutaseal nipple M20 8-12mm Grey RAL7001	2
17	690160070	Plug 7 poles DIN 72 577 – ISO 1724	1
18	7357546	Rubberbushing Nr. 38A Ø10/3 black	1
19	0520492	Junction box 105x105x60	1

Notice: Check measurements of wires before ordering spare parts.

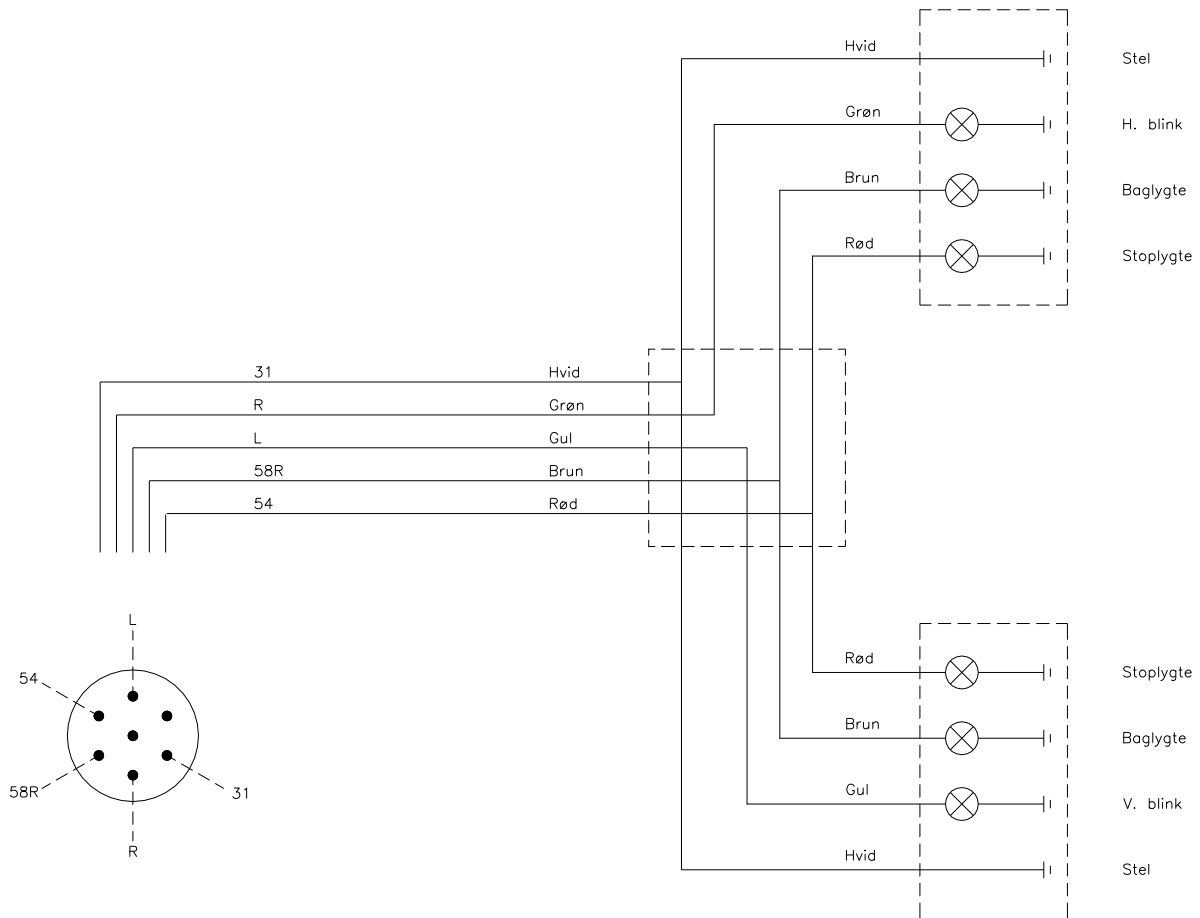
Light kit: El. diagram

Danish		English	
31	Hvid	White	Frame
R	Grøn	Green	Right turn
L	Gul	Yellow	Left turn
58R	Brun	Brown	Rear light
54	Rød	Red	Brake light

Spring-Board w/ fixed mounted wearing points and traverse locking system

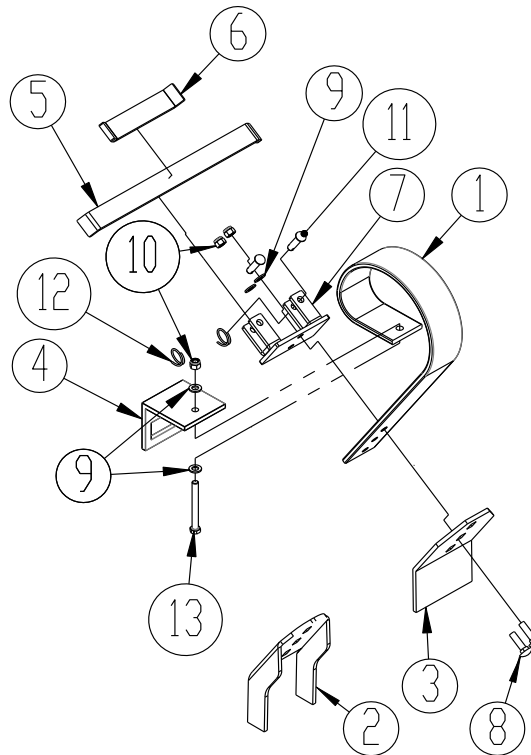

Pos.	Part no.	Description	Pc.
1	0422145	Spring-board tine 80x10 - long	1
2	633052100	Slicing point (crust breaker)	1
3	633052150	Wearing point for Spring-Board tine	1
4	633052200	Mounting piece for Spring-Board tine	1
5	633055710	Lock bar (long) for traverse locking system	1
6	633055700	Lock bar (short) for traverse locking system	1
7	633055500	Traverse bracket for locking system	1
8	690101220	Carriage bolt M12x45 8.8	2
9	690117014	Faceted washer Ø12	4
10	690113006	Safety nut	3
11	69512040K	Pin Ø12,5 L = 40 St 52 Yellow Zink Plated	2
12	690134000	Locking ring 30xø3 Galvanized	2
13	690103098	Bolt M12x110 10.9	1

Spring-Board mounting w/easy change

Wearing points and Slicing point (Crust breaker) and traverse locking system

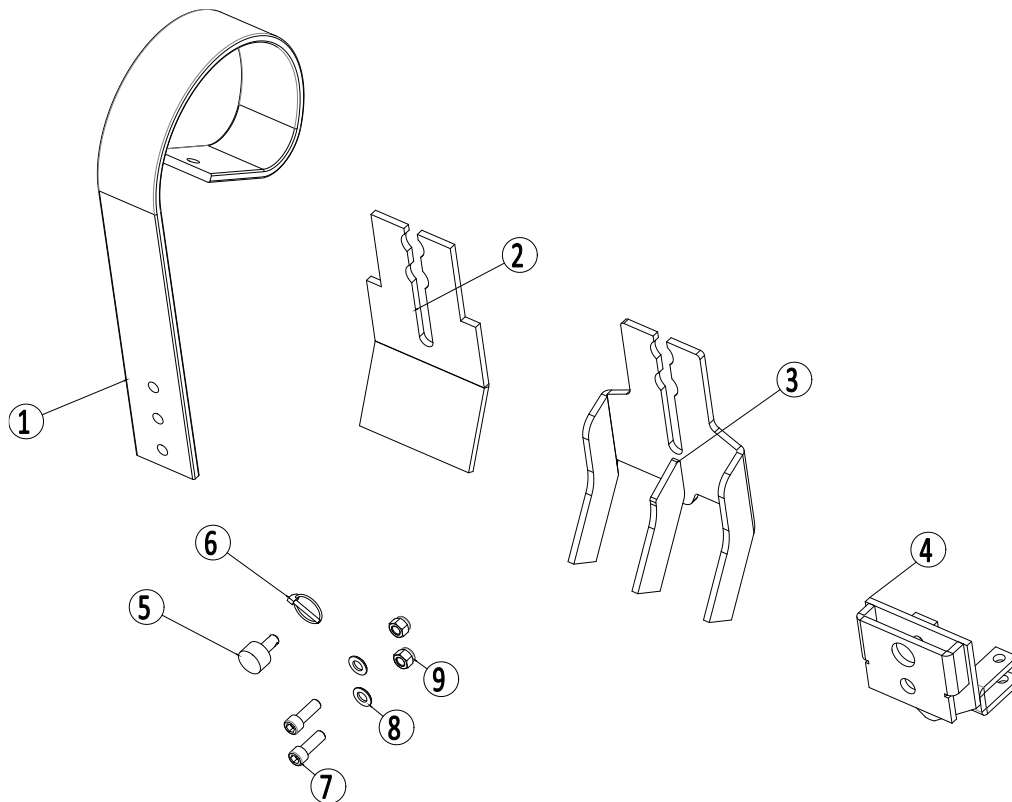

Pos.	Part no.	Description	Pc.
1	0422145	Spring-Board tine	1
2	1170388	Flat wearing point – Easy-Change	1
3	1170410	3 – point Slicing point (Crust breaker) – Easy-Change	1
4	1170389	Easy-Change bracket for traverse locking system	1
5	1170391	Locking pin	1
6	0378200	Locking ring Ø4,5 mm	1
7	0227842	Bolt M12 x 35 8.8	2
8	0272270	Faceted washer	2
9	0264070	Safety nut M12	2

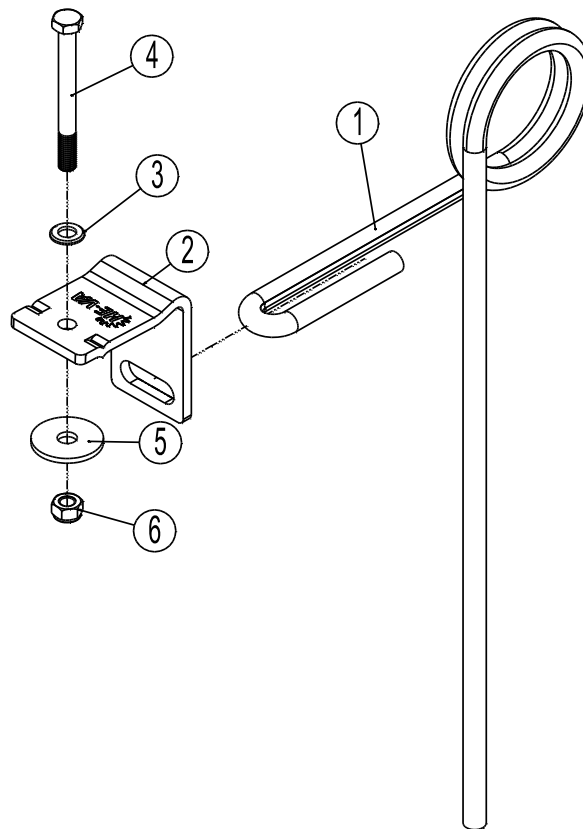

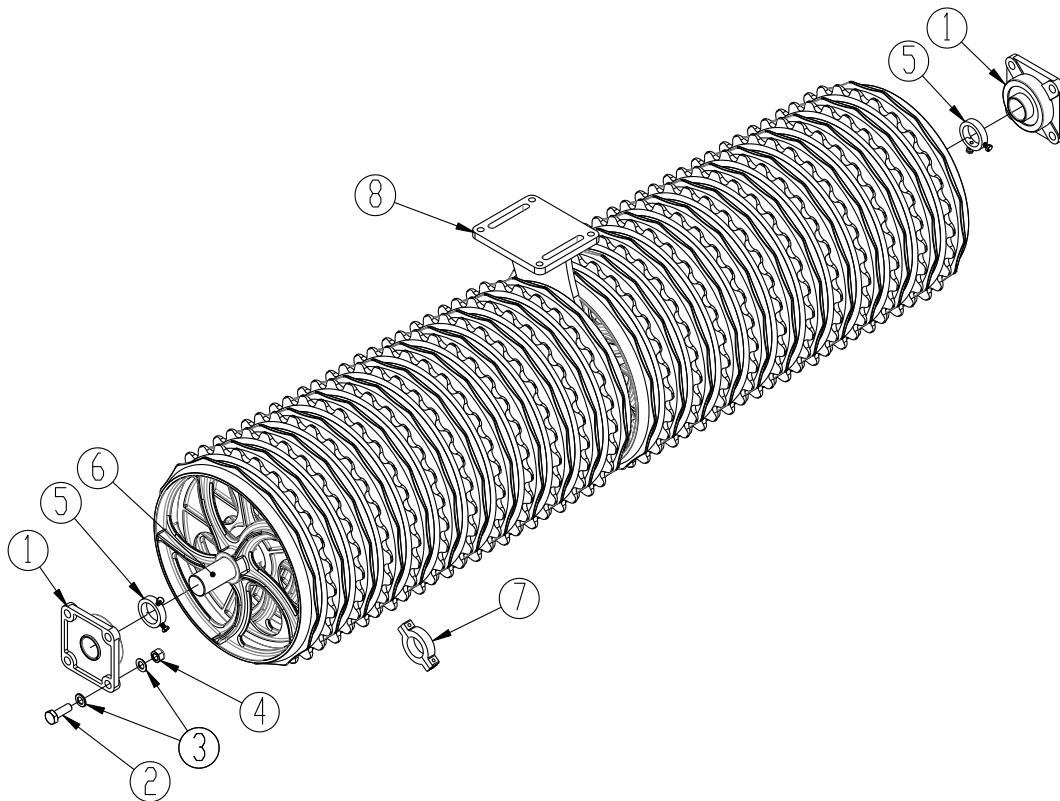

Ø16 mm tine for strigle

Pos.	Part no.	Description	Pc.
1	633055609	Tine for strigle Ø16 H=655mm	1
2	633055612	Mounting bracket	1
3	0272270	Faceted washer 12mm fzb, DIN125B	1
4	0235480	Bolt M12x120 8.8	1
5	0272820	Flat washer	1
6	0264070	Safety nut M12, fzb DIN985	1

Roller section

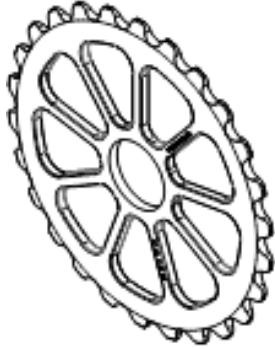
Pos.	Part no.	Description	12,3m	15,3m
1	0478971	Bearing UCF 312 Ø60	10	10
2	0236130	Bolt M20x60 8.8 fzb	40	40
3	0272310	Faceted washer Ø20 DIN125B	80	80
4	0264110	Safety nut M20	40	40
5	671040400	Stop ring w/2 stk. M12 bolts (for Ø60 axle)	10	10
6	678612710	Axle Ø59,95 h9, E335C, outer sec. + side sec. at 12,3m	4	2
6	678614210	Axle Ø59,95 h9, E335C, side section	-	2
6	678612920	Axle Ø59,95 h9, E335C, middle section	1	1
7	690150090	Adjustment shim 15 mm, incl bolts	5	5
7	690150099	Adjustment shim 20 mm, incl bolts	5	5
7	690150091	Adjustment shim 25 mm, incl bolts	5	5
8	Support bearing	See page 36 - 37	5	5

Cambridge- and Corrugated rings overview

Cambridge rings Ø560 mm with 9 spokes		Description	Quality	Part no.
<p>Pos. 1 560 mm Plain ring (9 spokes)</p> 	<p>Pos. 2 560 mm Breaker ring (9 spokes)</p> 	Pos. 1 Hub 104 mm	GG25	7375005
		Pos. 1 Hub 104 mm	GGG50	7375009
		Pos. 1 Hub 80 mm	GG25	7375007
		Pos. 1 Hub 80 mm	GGG50	7375011
		Pos. 1 Hub 72 mm	GG25	7375017
		Pos. 1 Hub 72 mm w/bearing	GGG50	7375023
		Pos. 1 Hub 82 mm w/bearing	GG25	7375018
		Pos. 1 Hub 82 mm w/bearing	GGG50	7375024
		Pos. 2	GG25	7375000
		Pos. 2	GGG50	7375012
Cambridge rings Ø620 mm with 10 spokes		Description	Quality	Part no.
<p>Pos. 3 620 mm Plain ring (10 spokes)</p> 	<p>Pos. 4 620 mm Breaker ring (10 spokes)</p> 	Pos. 3 Hub 104 mm	GG25	690150113
		Pos. 3 Hub 104 mm	GGG50	7375016
		Pos. 3 Hub 80 mm	GG25	690150111
		Pos. 3 Hub 80 mm	GGG50	7375015
		Pos. 3 Hub 72 mm v/leje	GG25	630764049
		Pos. 3 Hub 72 mm v/leje	GGG50	7375021
		Pos. 3 Hub 82 mm v/leje	GG25	630764050
		Pos. 3 Hub 82 mm v/leje	GGG50	7375022
		Pos. 4	GG25	690150067
		Pos. 4	GGG50	690150116
2D Curroged rings		Description	Quality	Part no.
<p>Pos. 5 Curroged ring (10 spokes)</p> 	Pos. 5 Ø550	GG25	7375007	
	Ø550 Hub 67 mm See next page	GGG50	7375050	
	Ø550 Hub 72 mm See next page	GGG50	7375023	
	Pos. 5 Ø600	GG25	690150111	
	Ø600 Hub 67 mm See next page	GGG50	7375051	
	Ø600 Hub 72 mm See next page	GGG50	7375021	

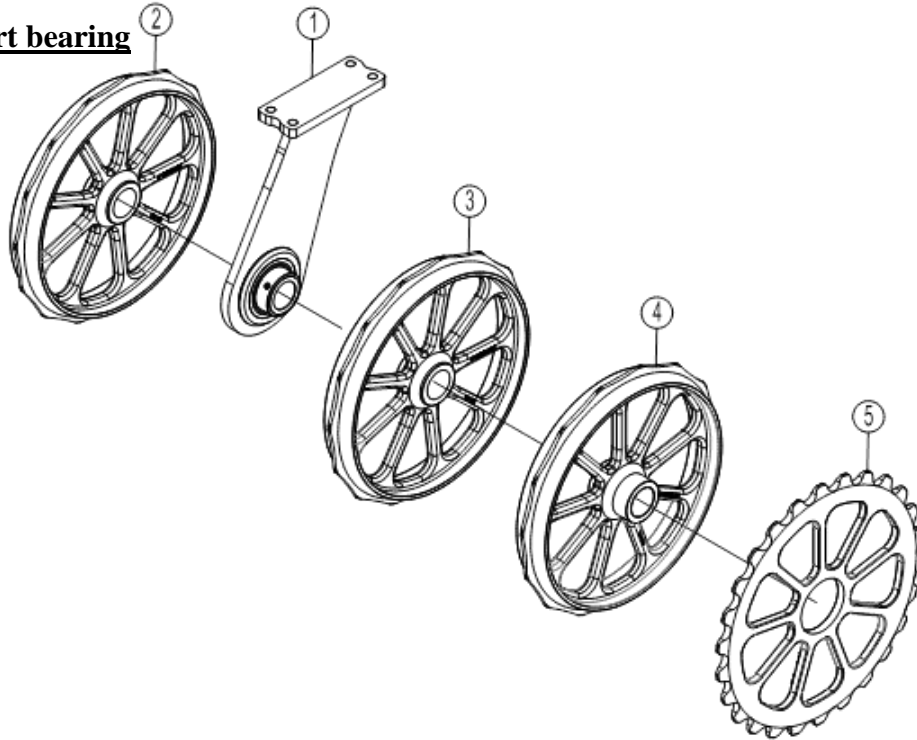

Rings at support bearing

Pos.	Description
1	Support bearing
2	Ring with hub 72 mm
3	Ring with hub 82 mm
3	Ring with hub 67 mm (see page 34) ONLY w/ 2D – Currogated rings
4	Ring with hub 104
5	Breaker ring standard

Star- and Crosskill rings overview

Star rings Ø550/Ø600 mm			Description	Quality	Part no.
Pos. 6 600 mm 	Pos. 7 550 mm 	Pos. 8 235 mm 	Pos. 6 Ø600/Ø135	GGG50	690150065
			Pos. 7 Ø550	GGG50	690150066
			Pos. 8 Mounting plate		690150112

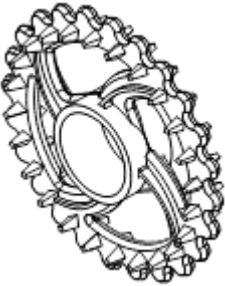
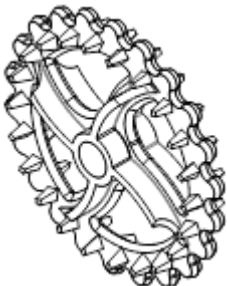
Continued →

Crosskill 485/530 mm – 550/600 mm			Description	Quality	Part no.
Pos. 9 Loose Crosskill 	Pos. 10 Fixed Crosskill 	Pos. 11 Hub 	Pos. 9 600 mm	GG25	690150075
			Pos. 10 550 mm	GG25	690150074
			Pos. 11 Hub Ø104		690150076

Support bearing

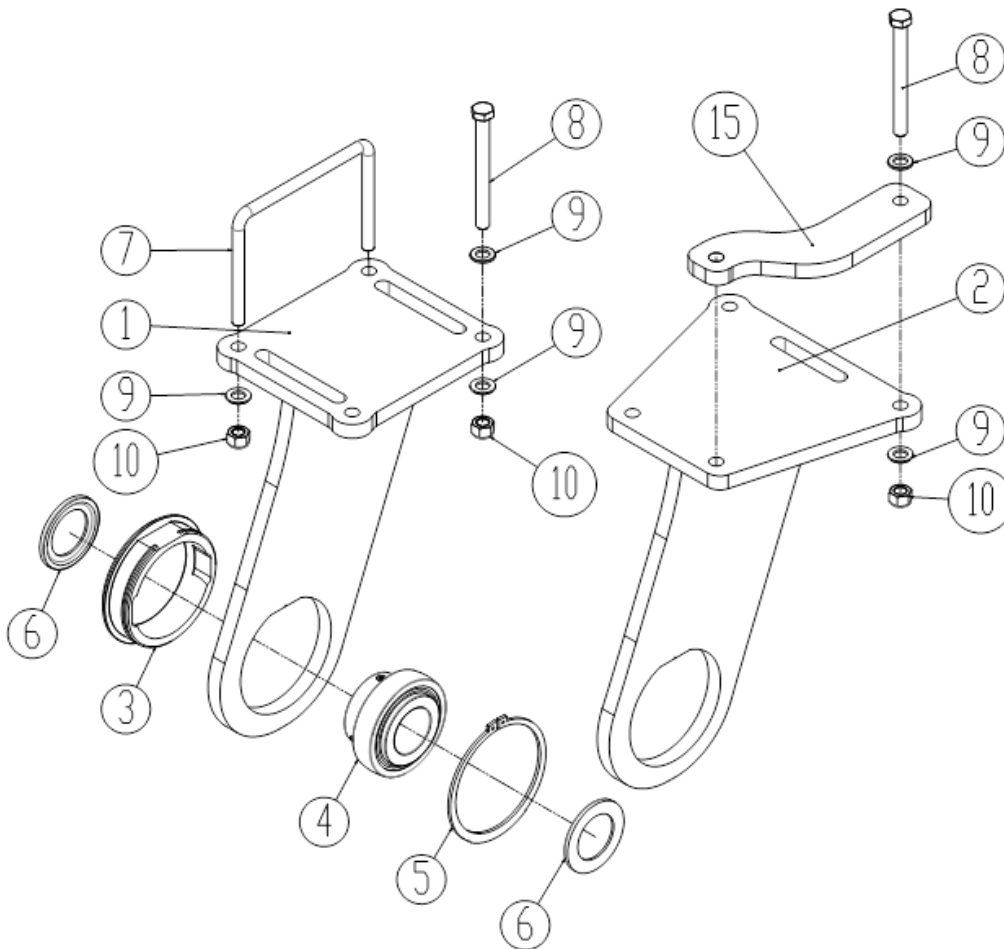

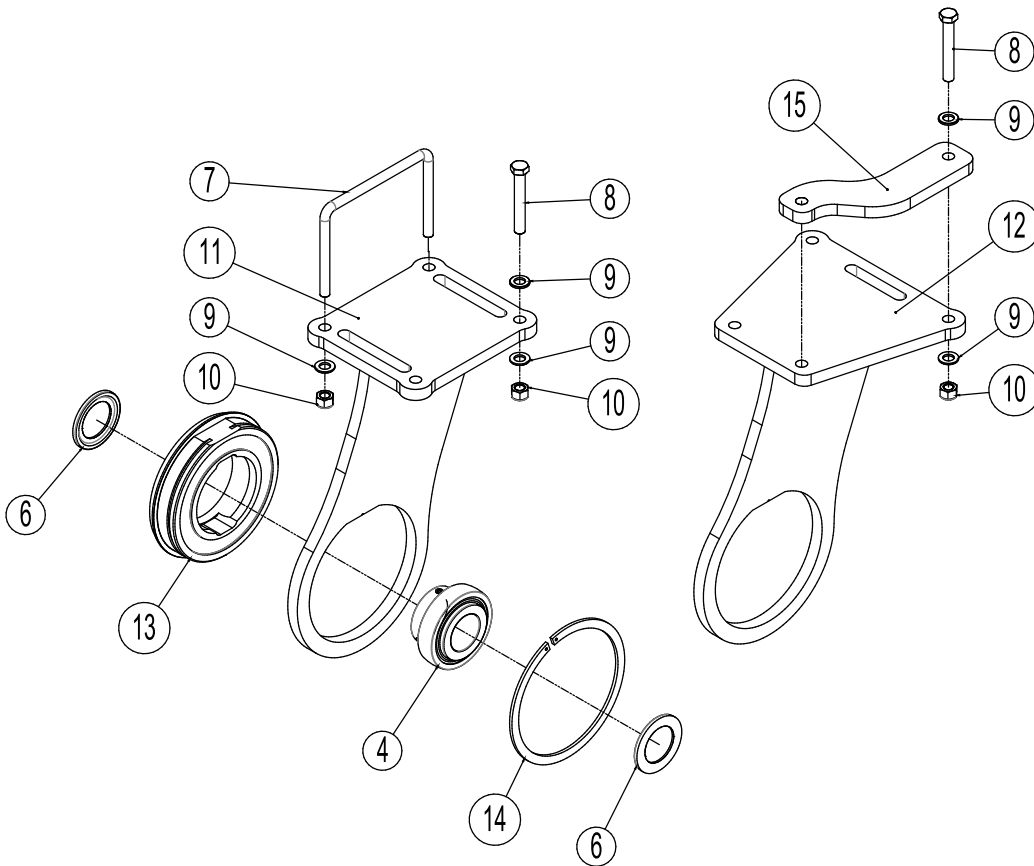
Support bearing with rubber (additional equipment)

Pos.	Part no.	Description	12,3m	15,3m
1	630850263	Console for support bearing, side- and outer section	4	4
2	630850271	Console for support bearing, center section	1	1
3	630764008	Holder for support bearing	5	5
4	690140116	Bearing UC312 R3	5	5
5	691370150	Seeger circlip ring Ø150 DIN 471	5	5
6	7355000	Thrust plate, narrow f/ UCF312 hub	10	10
7	690110105	U-bolt M16 100x200x100 (kun yderled)	4	4
8	690103117	Bolt M16x160 mm 8.8	12	12
9	0272290	Faceted washer Ø16 – DIN125B	32	32
10	0265090	Safety nut M16	20	20
11	1215112	Console f/support bearing with rubber. Side- outer sec.	4	4
12	1215113	Console f/support bearing with rubber. Center section	1	1
13	7355040	Holder for bearing with rubber for UC312	5	5
14	691370220	Seeger circlip ring Ø220 DIN471	5	5
15	630850268	Plate f/mounting of sup. bearing at the Mittelsection	2	2

Noter

--	--

Hydraulic

Side sections

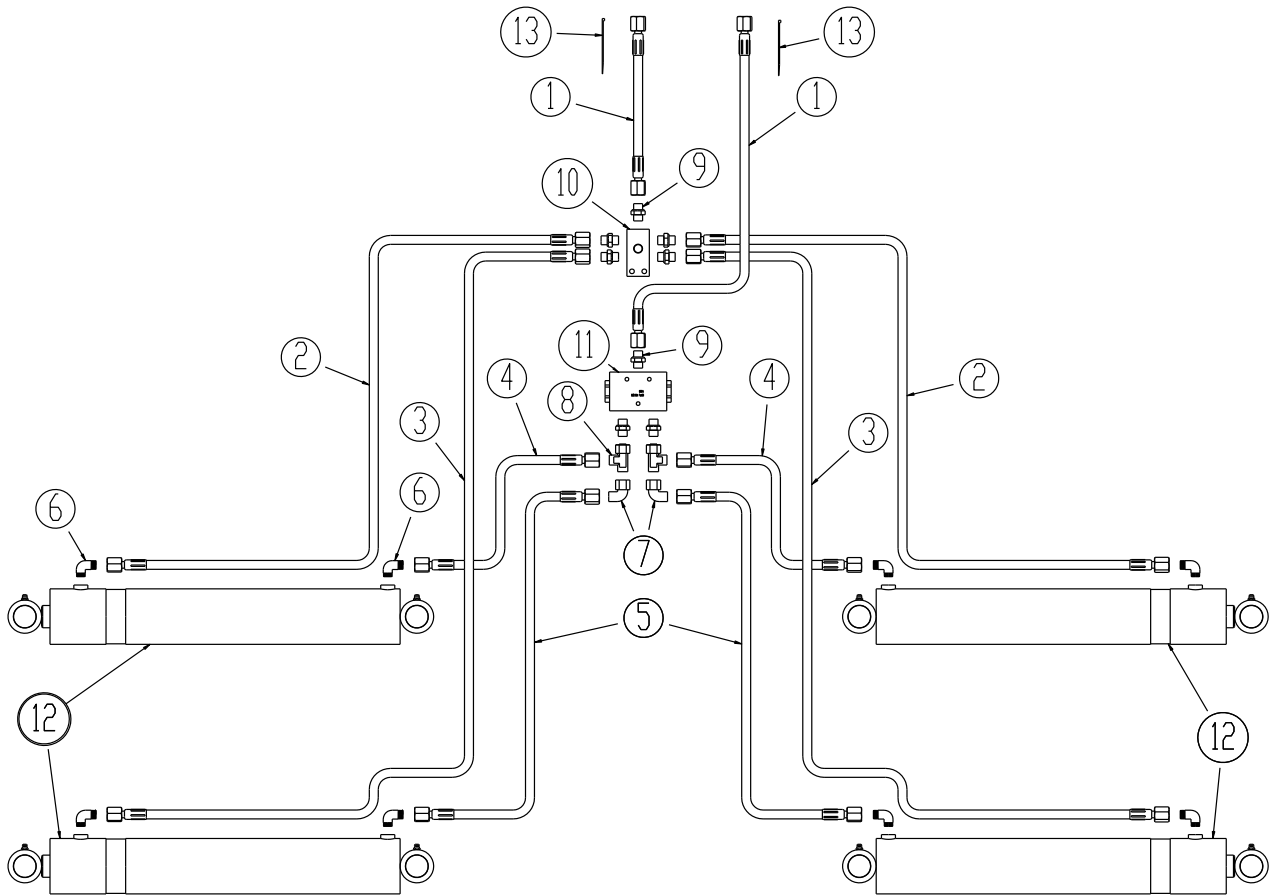

Pos.	Part no.	Description	12,3 m	15,3 m
1	0455416	Hydraulic hose 3/8" L = 9750 mm	2	
1	0455490	Hydraulic hose 3/8" L = 11250 mm		2
2	0454916	Hydraulic hose 3/8" L = 3300 mm	2	2
3	0454675	Hydraulic hose 3/8" L = 2500 mm	2	2
4	0454798	Hydraulic hose 3/8" L = 2800 mm	2	2
5	0454578	Hydraulic hose 3/8" L = 1995 mm	2	2
6	690203106	Fitting, 90° angle 12- 3/8" BSP	8	8
7	690203112	Fitting adjustable, 90° angle 12 mm	2	2
8	690203017	Tee T12 L w/ O-ring	2	2
9	0446754	Connector, 2 x male thread, Ø12 x 3/8"	8	8
10	660501415	Aluminum connector 40x40x85, 6 gates	1	1
11	0442775	Flowdivider 3/8" 50x50% 10 – 20 l/min	1	1
12	7345033	Cylinder 90/40-500, ø40/ø40	4	4
13		Blue strips	2	2

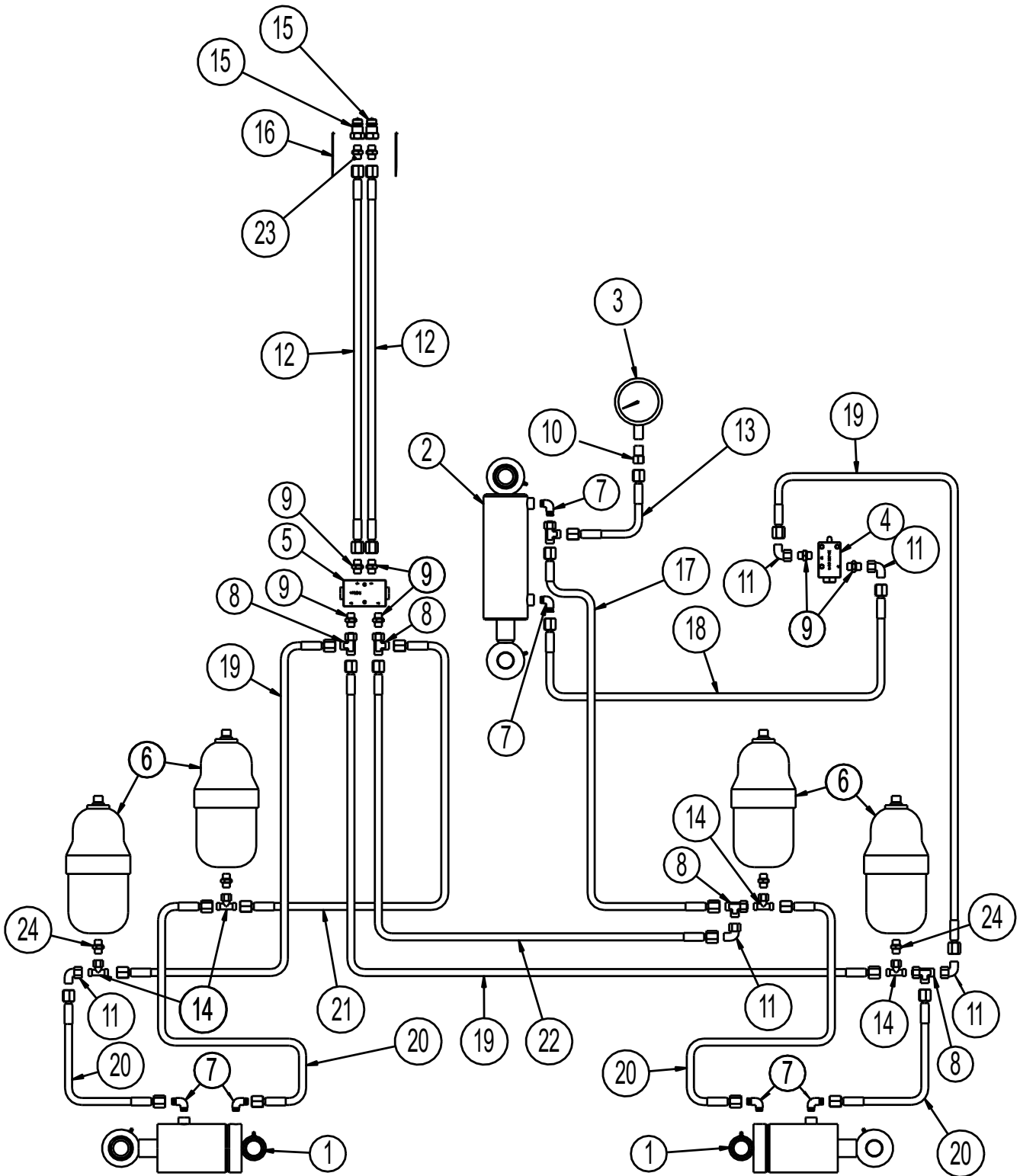
Weight distribution system, outer- and center section

Pos.	Part no.	Description	12,3 m	15,3 m
1	7345020	Cylinder Ø100/40 x 50 ø35/ø35	2	2
2	7345037	Cylinder Ø90/40 x 155 ø35/ø35 2 x rod eyes	1	1
3	690206822	Pressure guage 250 bar, ø100	1	1
4	690207101	End stop valve FC10NC	1	1
5	0442512	Pilot controlled non return valve 3/8"	1	1
6	690206510	Accumulator HST 2,3L 40 bar	4	4
7	690203106	Fitting, 90° angel 12-3/8"	6	6
8	690203017	Tee adjustable T12 L, w/O-ring	5	5
9	0446754	Connector, 2 x male thread, Ø12 x 3/8"	12	12
10	690206825	Fitting for pressure gauge	1	1
11	690203112	Fitting, adjustable 90° 12 mm	5	5
12	0455391	Hydraulic hose 3/8" L = 9560 mm	2	-
12	0455460	Hydraulic hose 3/8" L = 11100 mm	-	2
13	0454935	Hydraulic hose 3/8" L= 3610 mm	1	-
13	0454994	Hydraulic hose 3/8" L = 5340 mm	-	1
14	690203125	Stilbar T12 L	4	4
15	0444020	Lynkobling 1/2"	2	2
16	-	Yellow strips	2	2
17	0454941	Hydraulic hose 3/8" L = 3800 mm	1	1
18	04544936	Hydraulic hose 3/8" L = 3700 mm	1	1
19	690201205	Hydraulic hose 3/8" L = 1130 mm	3	3
20	0454994	Hydraulic hose 3/8" L = 5340 mm	4	4
21	0454254	Hydraulic hose 3/8" L = 1010 mm	1	1
22	0454217	Hydraulic hose 3/8" L = 810 mm	1	1
23	690203103	Fitting, straight Ø12 – 1/2"	2	2
24	690203097	Fitting, straight M18x1,5 – Ø12	4	4

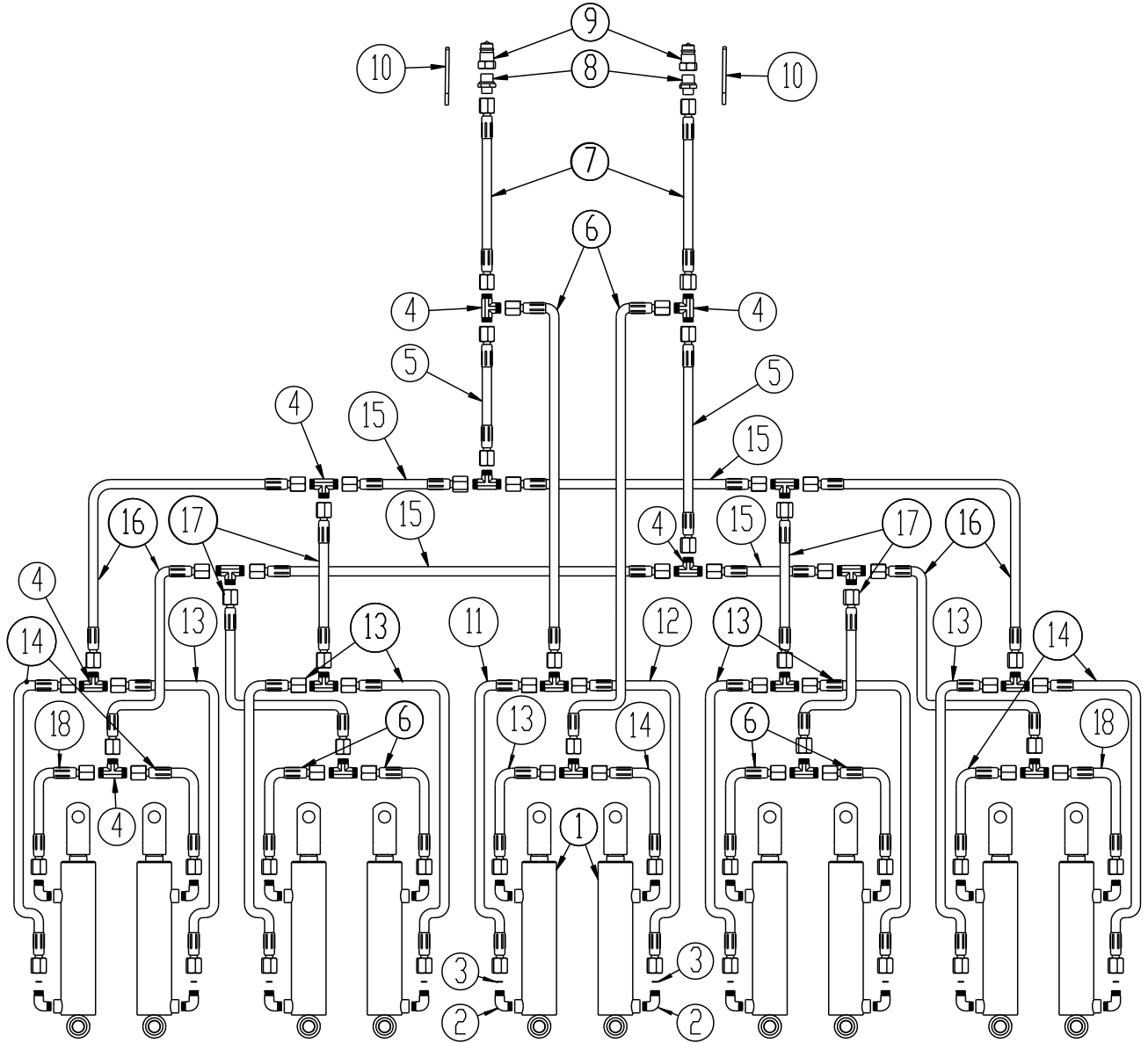
Spring-Board

Pos.	Part no.	Description	12,3 m	15,3 m
1	690200160	Cylinder 50/30x135	10	10
2	690203106	Fitting, 90° angel 12-3/8" BSP	20	20
3	690207901	Restrictor (1 mm)	10	10
4	690203115	Tee, 3 x male thread T12	18	18
5	690201232	Hydraulic hose 3/8" L = 3530 mm	2	2
6	0454254	Hydraulic hose 3/8" L = 1010 mm	6	6
7	0455026	Hydraulic hose 3/8" L = 6000 mm	2	2
8	690203103	Connector Ø12 x 1/2" BSP	2	2
9	0444020	Quick coupling 1/2"	2	2
10		Green straps	2	2
11	0454186	Hydraulic hose 3/8" L = 625 mm	1	1
12	0454212	Hydraulic hose 3/8" L = 710 mm	1	1
13	0454217	Hydraulic hose 3/8" L = 820 mm	7	7
14	0454244	Hydraulic hose 3/8" L = 935 mm	5	5
15	0454972	Hydraulic hose 3/8" L = 4610 mm	4	-
15	0454994	Hydraulic hose 3/8" L = 5340 mm	-	4
16	0454798	Hydraulic hose 3/8" L = 2800 mm	4	-
16	0454935	Hydraulic hose 3/8" L = 3610 mm	-	4
17	0454172	Hydraulic hose 3/8" L = 500 mm	4	4
18	690201205	Hydraulic hose 3/8" L = 1130 mm	2	2

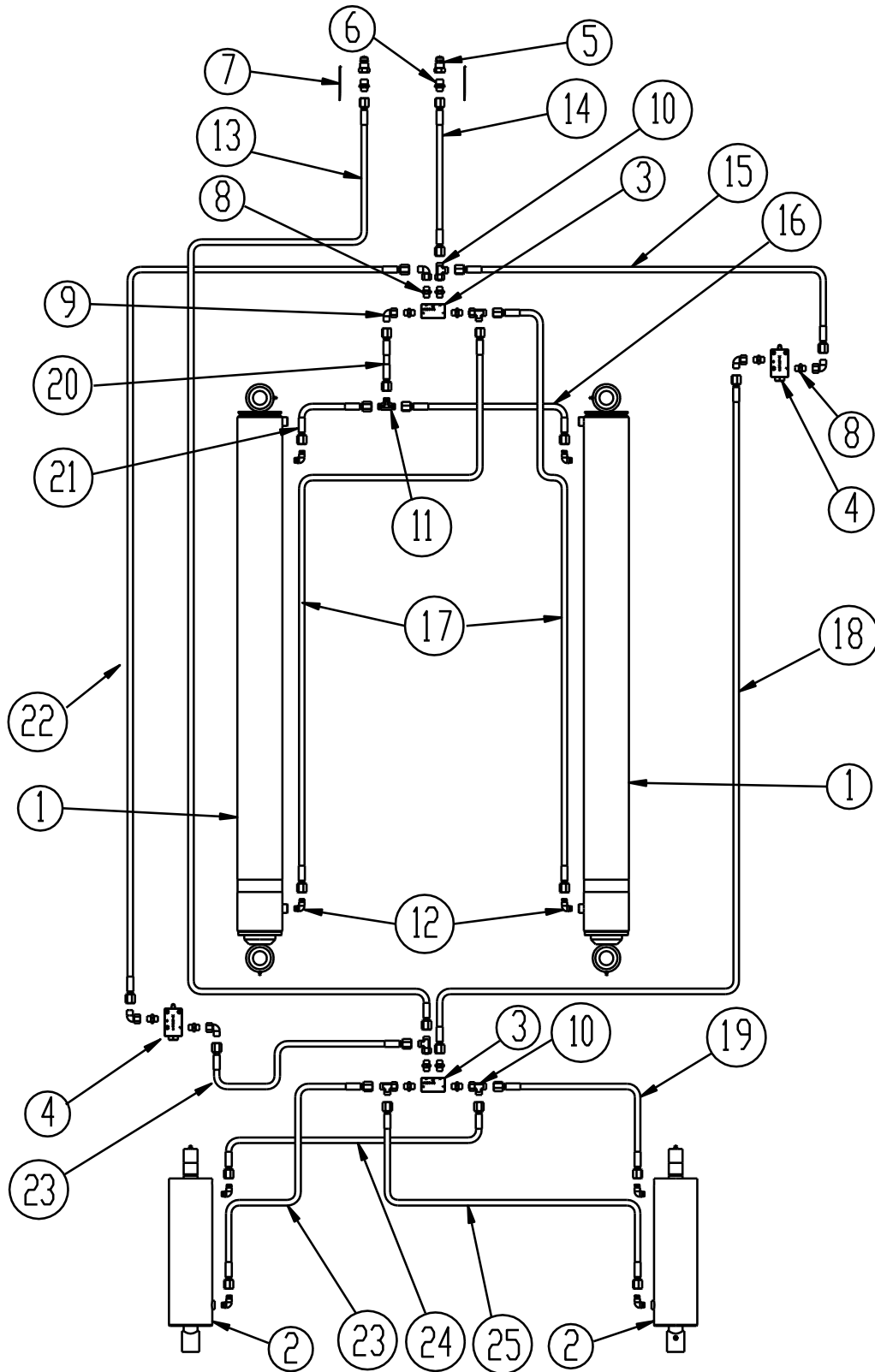
Tipping cylinder

Pos.	Vare nr.	Betegnelsen	12,3 m	15,3 m
1	7345028	Cylinder 110/90 x 1300	2	2
2	7345042	Cylinder 110/40 x 285	2	2
3	0442510	Pilot controlled non return valve 3/8"	2	2
4	690207101	End stop valve FC10NC	2	2
5	0444020	Quick coupling 1/2"	2	2
6	690103103	Fitting, straight Ø12 x 1/2" BSP	2	2
7	-	Red strips	2	2
8	0446754	Fitting straight Ø12 x 3/8"	12	12
9	690203112	Fitting, adjustable 90° Ø12 mm	6	6
10	690203017	Tee adjustable T12 L, w/O-ring	5	5
11	690203115	Tee connector T12	1	1
12	690203106	Fitting, adjustable 90° 12-3/8" BSP	8	8
13	0455460	Hydraulic hose 3/8" L = 11100 mm	1	1
14	0455026	Hydraulic hose 3/8" L = 6000 mm	1	-
14	0455098	Hydraulic hose 3/8" L = 7450 mm	-	1
15	0454314	Hydraulikslange 3/8" L = 1130 mm	1	-
15	0454798	Hydraulikslange 3/8" L = 2800 mm	-	1
16	0454172	Hydraulikslange 3/8" L = 500 mm	1	1
17	0454556	Hydraulikslange 3/8" L = 1830 mm	2	2
18	0454972	Hydraulikslange 3/8" L = 4610 mm	1	-
18	0455034	Hydraulikslange 3/8" L = 6350 mm	-	1
19	0454314	Hydraulikslange 3/8" L = 1130 mm	1	1
20	0454314	Hydraulikslange 3/8" L = 1130 mm	1	1
21	0454164	Hydraulikslange 3/8" L = 400 mm	1	1
22	0454988	Hydraulikslange 3/8" L = 4950 mm	1	1
23	0454360	Hydraulikslange 3/8" L = 1260 mm	2	2
24	0454254	Hydraulikslange 3/8" L = 1010 mm	1	1
25	0454440	Hydraulikslange 3/8" L = 1460 mm	1	1

Support leg

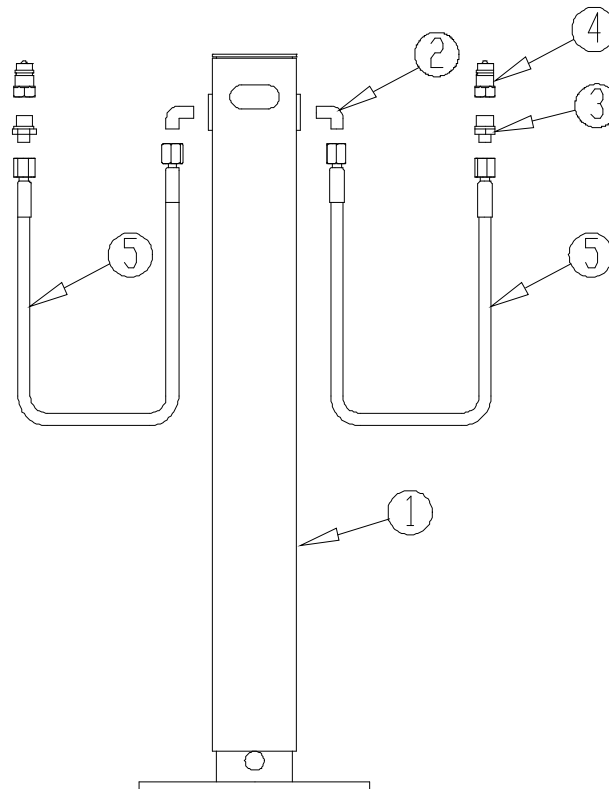

Pos.	Vare nr.	Betegnelse	12,3 m	15,3 m
1	690141105	Support leg	1	1
2	690203006	Fitting 90° angle 10-3/8" BSP	2	2
3	0446752	Fitting straight 10-3/8" BSP	2	2
4	0444020	Quick coupling 1/2"	2	2
5	690201047	Hydraulic hose 1/4" L	2	2

ATTENTION: When ordering new hydraulic hoses, always check the length incl. fittings.

Disposal

When, after many years of use, the machine is to be regarded as end-of-life, it must be disposed of to a registered and approved product dealer. This will carry out the statutory discharge and disposal of hydraulic oil, as well as sorting materials for further processing for recycling.

GOOD AS IT LOOKS!
AS GOOD AS IT LOOKS!
AS GOOD AS IT LOOKS!
AS GOOD AS IT LOOKS!
AS GOOD AS IT LOOKS!
AS GOOD AS IT LOOKS!



The design is subject to modification without notice.